

# Moulding

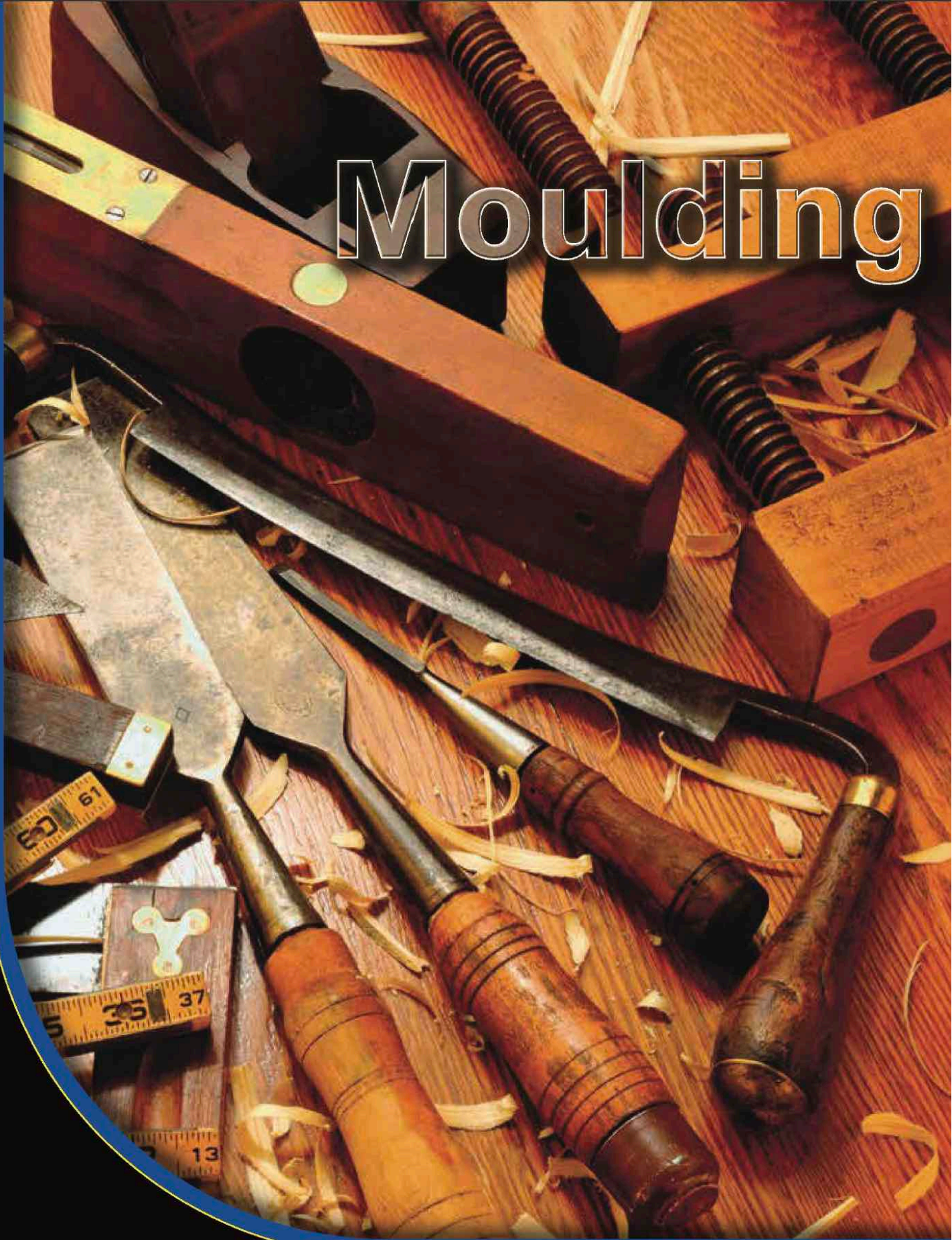



## QUALITY PRODUCTS OFFERED BY BERONIO LUMBER

Decking | Fencing | Finish Lumber | Flooring | Framing | Paneling | Shingles  
Siding | Stair Parts | Engineered Lumber | Wainscot | Moulding

### Lumber Yard and Showroom:

2525 Marin Street (at Bayshore)  
San Francisco, CA 94124

Tel: (415) 824-4300

Fax: (415) 824-3706

### Business Hours:

(Please check our website at [beronio.com](http://beronio.com) as hours may change)

Monday–Friday 6:00 am - 4:30 pm

Saturday 7:00 am - 12:00 pm

# SUPPLYING THE BAY AREA WITH THE FINEST BUILDING MATERIALS SINCE 1911

ALTHOUGH WE HAVE TRIED TO APPROXIMATE AS CLOSELY AS POSSIBLE THE ORIGINAL COLOR OF THE WOOD, NATURAL COLOR VARIANCES WILL EXIST WHEN COMPARED TO THE ACTUAL PRODUCT. THERE ARE NO REPRESENTATIONS OR WARRANTIES, EXPRESS OR IMPLIED OF ANY KIND WHATSOEVER, INCLUDING BUT NOT LIMITED TO REPRESENTATIONS OR WARRANTIES OF FITNESS FOR A PARTICULAR PURPOSE OF MERCHANTABILITY, WHICH EXTENDED BEYOND THE DESCRIPTION OF THE FACE HEREOF. SELLER'S LIABILITY SHALL BE LIMITED TO REPLACEMENT OR RESCISSION AT ITS SOLE ELECTION AND IN NO EVENT WILL SELLER BE LIABLE FOR CONSEQUENTIAL OR PUNITIVE DAMAGES. ANY REPRODUCTION OF THIS CATALOG IN WHOLE OR IN PART, OR ANY OTHER UNAUTHORIZED USE WITHOUT THE EXPRESS PERMISSION OF THE BERONIO LUMBER COMPANY IS PROHIBITED.

Beronio Lumber was founded in 1911 by Antone V. Beronio. The original yard was located on Powell and Beach streets on, what was then, San Francisco's busy waterfront. The yard serviced the countless contractors who were busy rebuilding the city. This was the era of the proud craftsman. Quality millwork was the standard. Doors were hung on the job, usually with a dime thickness tolerance.

The city was blessed with numerous millwork houses producing doors, windows, circular stairs and custom details. Each firm had its signature moulding series. It was this wonderful diversity that created the rich architectural heritage that San Francisco still enjoys today.

From the beginning, Beronio Lumber was actively involved in the millwork business providing raw material and finished millwork. Over the years, we've gathered a rich assortment of patterns and profiles. Every item in the front section of this catalog is kept in stock. The specie of each stock item is listed. The majority of patterns are "Paint Grade". Paint Grade profiles are generally stocked in either primed FJ Pine, or unprimed FJ or solid Poplar.

Finger-joint paint grade stock is designed to yield a good quality brush finish for most applications. However, in demanding applications where a "porcelain smooth" spray finish is desired and there is zero tolerance for "grain or finger-joint" telegraph, we strongly recommend that all trim be manufactured from solid hardwood lumber.

Our program is always in development. New patterns are being added. Old ones modified. At best, this catalog is a snapshot. Please give us a call before finalizing your specifications.

Finally, we take great pride in the dedication and skill of our millwork craftsmen. They are all dedicated professionals who still adhere to the "dime tolerance" school. Fact is, some of our most impressive work is not pictured in this catalog. These are the numerous custom details they produced for specific jobs. So, if what you really need to complete your design is not pictured here, we'd love to turn your doodle, idea, napkin sketch, or line drawing into a fine wood moulding that will provide countless years of enjoyment. The drawings and resulting knife grinding templates are both developed on state of the art CAD Cam machines. We can provide you with detailed drawings prior to running the detail to aid in your design. We look forward to seeing you soon.



Casings & Related Patterns . . . . . 1

Crown, Cove & Picture Mouldings . . . . . 8

Crown, Cove & Miscellaneous Hardwood . . . . . 14

Bases & Base Caps . . . . . 15

Stops. . . . . 20

Paneling, Shingle & Stucco Mouldings . . . . . 21

Lattice, Screen & Edge Mouldings . . . . . 24

Rounds & Corner Mouldings . . . . . 25

Hardwood Rounds & Corner Mouldings / Miscellaneous . . . . . 26

Miscellaneous . . . . . 27

Hardwood Miscellaneous . . . . . 28

Hardwood Sill, Nosing & Reducers / Jambs & Sills . . . . . 29

Jambs & Sills . . . . . 30

Wainscotting & Paneling. . . . . 31

Flooring / Siding . . . . . 34

Siding . . . . . 35

Bodyguard Exterior Mouldings . . . . . 40

Stair Parts . . . . . 45

Exterior Mouldings . . . . . 51

Typical Moulding Assemblies. . . . . 61

Windsor Mill Mouldings Collection . . . . . 69

Installation Tips . . . . . 75

Moulding Pattern Index . . . . . 93

**A1J**  
**Paint Grade**  
 R/E Casing  
 5/8" x 1 5/8"



**A2J**  
**Paint Grade**  
 R/E Casing  
 3/4" x 2 1/2"



**A3J**  
**Paint Grade**  
 Bevel Casing  
 5/8" x 1 5/8"

**A4J**

**A4J**  
**Paint Grade**  
 Bevel Casing  
 5/8" x 2 1/4"

**A5R**  
**Redwood/Red Cedar**  
 Casing  
 5/8" x 2 1/4"



**A5J**  
**Paint Grade**  
 Casing  
 5/8" x 2 1/4"

**A6J**  
**Paint Grade**  
 Moulded Casing  
 5/8" x 3 1/4"

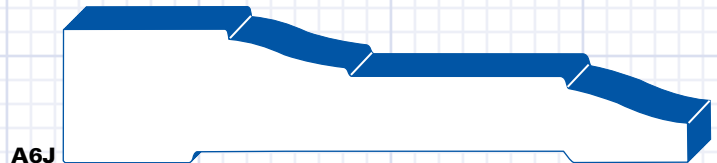

**A7**  
**Fir VG**  
 49'er Casing  
 1" x 3 1/4"

**A7J (Primed)**  
**Paint Grade**  
 49'er Casing  
 1" x 3 1/4"

**A6J**

**A8**  
**Redwood/Red Cedar**  
 "Beaded" Casing  
 5/8" x 3 1/2"

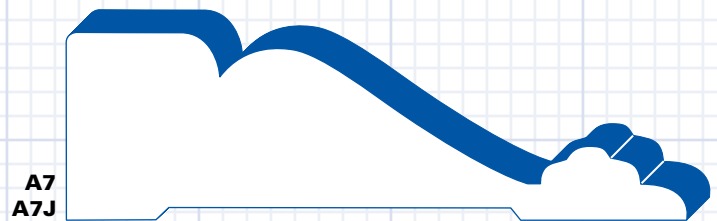

**A7**  
**A7J**

**A8J**  
**Paint Grade**  
 "Beaded" Casing  
 5/8" x 3 1/2"

**A9J**  
**Paint Grade**  
 Grillo Casing  
 5/8" x 2 1/2"

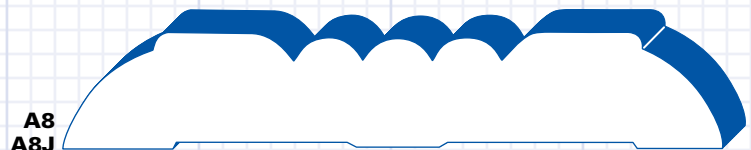

**A8**  
**A8J**

**A10J**  
**Paint Grade**  
 Coronado Casing  
 5/8" x 2 5/8"

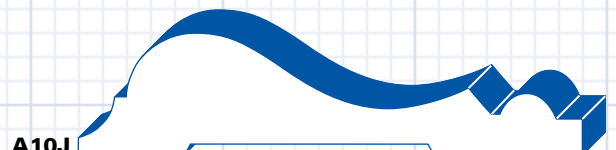
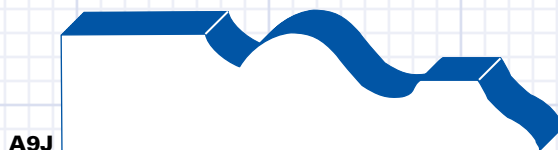

**A9J**

**A10J**

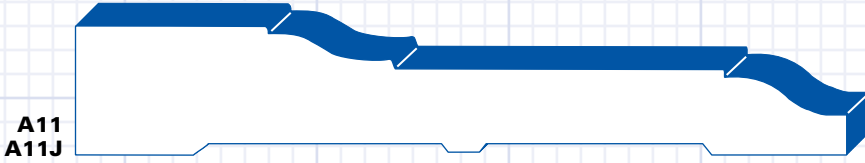

A11  
A11J

**A11**  
Redwood/Red Cedar  
Colonial Casing  
5/8" x 4"

**A11J**  
Paint Grade  
Colonial Casing  
5/8" x 4"

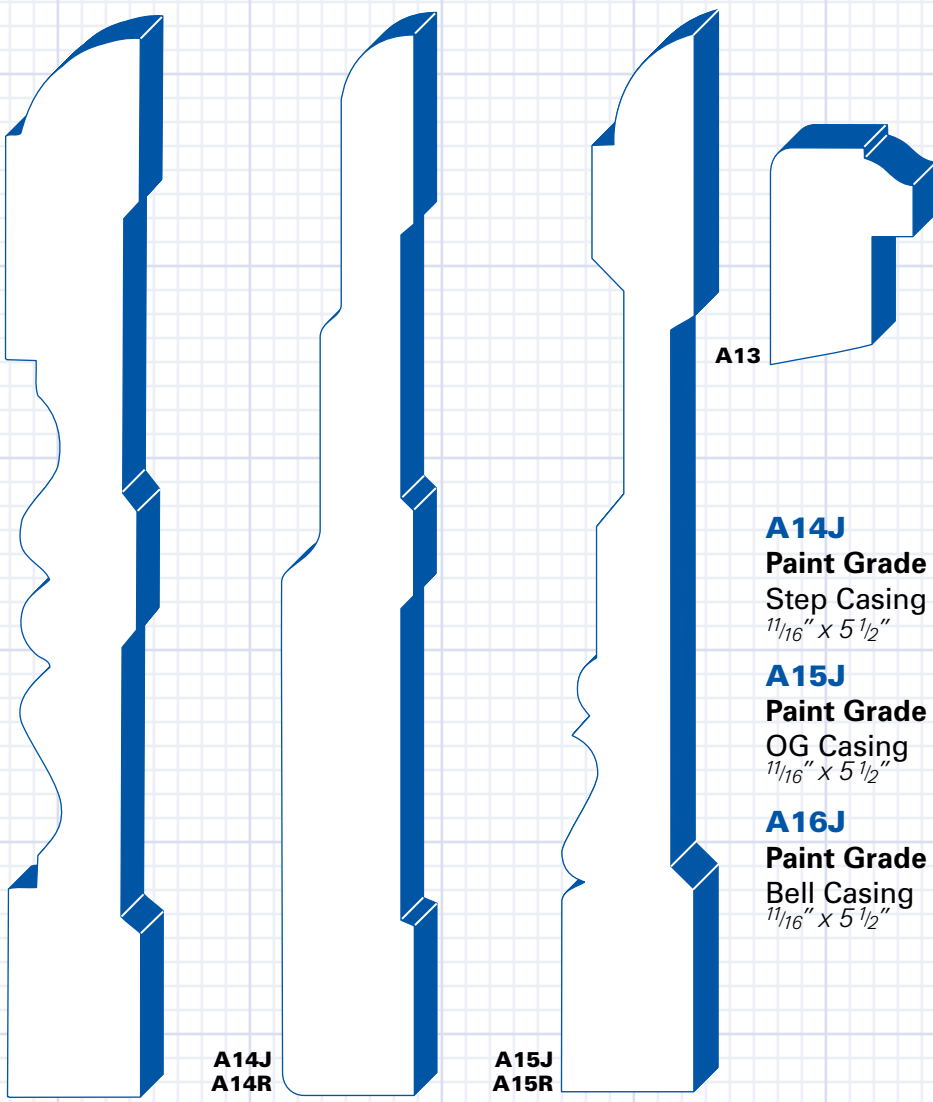

A12J  
A12R

A14J  
A14R

A15J  
A15R

A13

**A12J**  
Paint Grade  
Victorian Casing  
1 1/16" x 5 1/2"

**A12R**  
Redwood/Red Cedar  
Victorian Casing  
1 1/16" x 5 1/2"

**A13**  
Paint Grade  
Back Band  
3/4" x 1 1/8"

**A14J**  
Paint Grade  
Step Casing  
1 1/16" x 5 1/2"

**A14R**  
Redwood/Red Cedar  
Victorian Step Casing  
1 1/16" x 5 1/2"

**A15J**  
Paint Grade  
OG Casing  
1 1/16" x 5 1/2"

**A15R**  
Redwood/Red Cedar  
OG Casing  
1 1/16" x 5 1/2"

**A16J**  
Paint Grade  
Bell Casing  
1 1/16" x 5 1/2"

**A16R**  
Redwood/Red Cedar  
Bell Casing  
1 1/16" x 5 1/2"

**HW56\***  
House Whites  
Header Stock  
1" x 5 1/2"

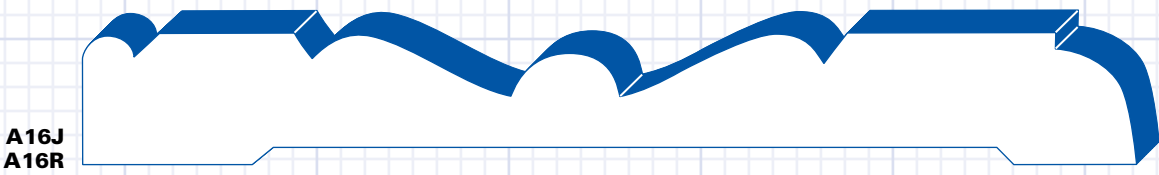

A16J  
A16R

HW56\* *Not shown to scale*



*\*Not shown to scale*

**A19J**  
**Paint Grade**  
 Plain Victorian  
 Casing  
 1 1/16" x 3 1/2"



**A19J**

**A20J**  
**Paint Grade**  
 Plain Victorian  
 Casing  
 1 1/16" x 5 1/2"

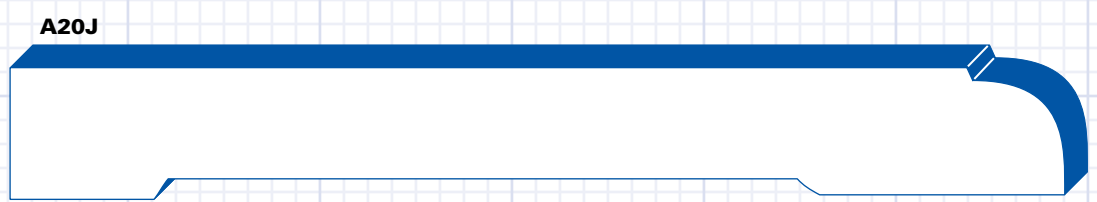

**A20J**

**A21A\***  
**Pine Victorian**  
 Corner Block  
 3/4" x 2 3/4"

**A21H\***  
**Pine Victorian**  
 Corner Block  
 1" x 3 3/4"

**A21P\***  
**Redwood Victorian**  
 Corner Block  
 1" x 5 3/4"

**A22J**  
**Paint Grade**  
 MPB Casing  
 5/8" x 2 5/8"

**A24J**  
**Paint Grade**  
 AVB Casing  
 5/8" x 3 1/2"

**A26J**  
**Paint Grade**  
 R/E Casing  
 3/4" x 3 1/2"

**A27S**  
**Solid Pine**  
 Alameda Casing  
 5/8" x 2 1/4"

**A21L\***  
**Paint Grade Victorian**  
 Corner Block  
 1" x 3 3/4"

**A21T\***  
**Pine Victorian**  
 Corner Block  
 1" x 4 1/4"

**A22R**  
**Redwood/Red Cedar**  
 MPB Casing  
 5/8" x 2 5/8"

**A24R**  
**Redwood/Red Cedar**  
 AVB Casing  
 5/8" x 3 1/2"

**A27J**  
**Paint Grade**  
 Alameda Casing  
 5/8" x 2 1/4"

**L130\***  
**Oak**  
 Victorian  
 7/8" x 3 3/4"

*\*Not shown to scale*

**A21A\***  
**A21H\***  
**A21L\***  
**A21P\***  
**A21T\***  
**L130\***

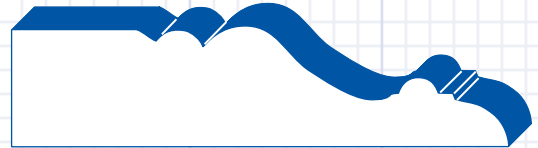
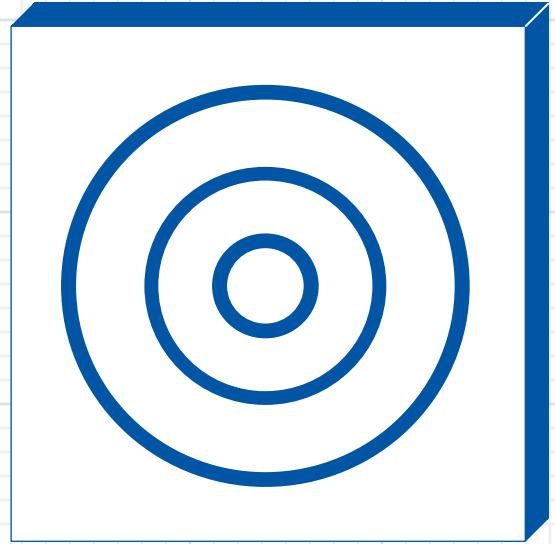

**A22J**  
**A22R**



**A24J**  
**A24R**



**A26J**

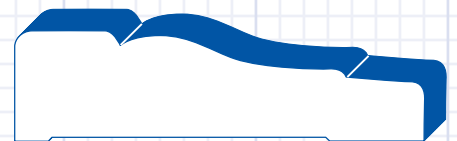

**A27J**  
**A27S**

*\*Not shown to scale*

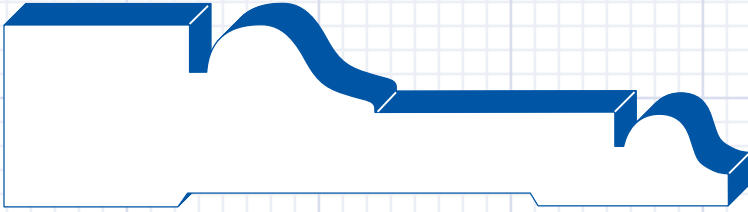

**A28J\***  
**A28R\***

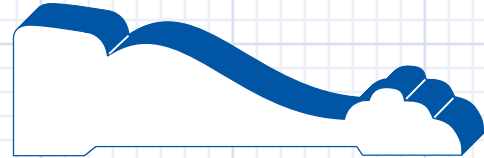

**A29J\***

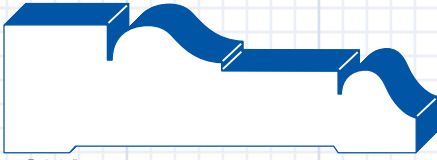

**A30\***  
**A30J\***  
**A30R\***

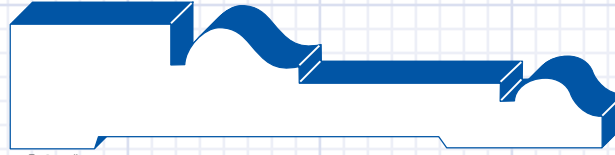

**A31\***  
**A31J\***

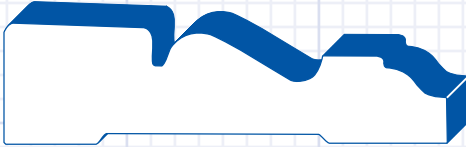

**A33J\***

**A28J\***  
**Paint Grade**  
Powell & Beach Casing  
1" x 4"

**A28R\***  
**Redwood/Red Cedar**  
Powell & Beach Casing  
1" x 4"

**A29J\***  
**Paint Grade**  
Marina Casing  
1 1/16" x 2 7/16"

**A30\***  
**VG Fir**  
Augusta Casing  
1 1/16" x 2 1/4"

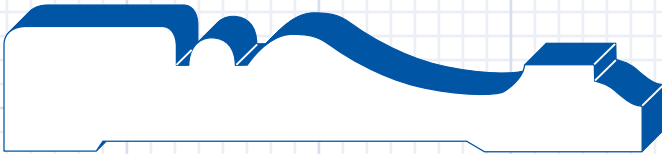

**A34J\***

**A30J\***  
**Paint Grade**  
Augusta Casing  
1 1/16" x 2 1/4"

**A30R\***  
**Redwood/Red Cedar**  
Augusta Casing  
1 1/16" x 2 1/4"

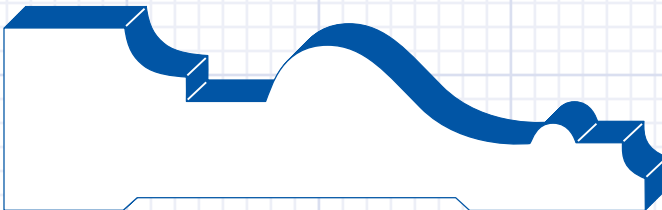

**A35J\***  
**A35R\***

**A31\***  
**VG Fir**  
Augusta Casing  
1 1/16" x 3 1/4"

**A31J\***  
**Paint Grade**  
Augusta Casing  
1 1/16" x 3 1/4"

**A33J\***  
**Paint Grade**  
Ballardo Casing  
5/8" x 2 1/2"

**A34J\***  
**Paint Grade**  
Beronio Casing  
5/8" x 3 1/2"

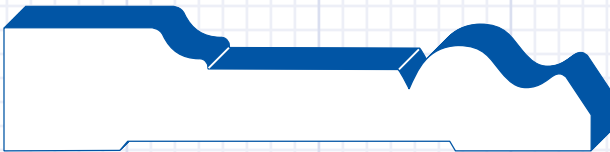

**A36\***

**A35J\***  
**Paint Grade**  
Power Casing  
1" x 3 1/2"

**A35R\***  
**Redwood/Red Cedar**  
Power Casing  
1" x 3 1/2"

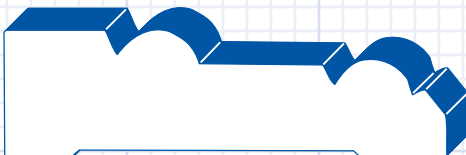

**A37\***

**A36\***  
**Red Knot**  
Country Casing  
1 1/16" x 3 1/4"

**A37\***  
**Red Knot**  
Country Casing  
1 1/16" x 2 1/2"

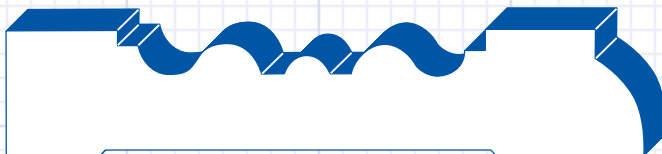

**A38J\***

**A38J\***  
**Paint Grade**  
Victorian Casing  
1 1/16" x 3 1/2"

*\*Not shown to scale*



**A39J**  
 Paint Grade  
 Perth Casing  
 1 1/16" x 2 1/2"

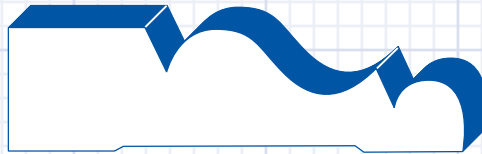

A39J

**A40J**  
 Paint Grade  
 Fluted Pilaster  
 1 1/16" x 5 1/2"



A40J

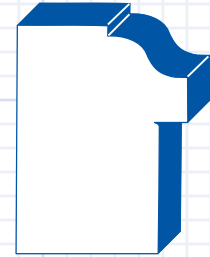

A41J  
 A41R

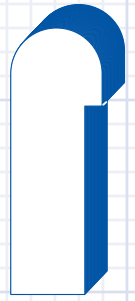

A46J

**A41J**  
 Paint Grade  
 Edge Band  
 1" x 1 1/4"

**A41R**  
 Redwood/Red Cedar  
 Edge Band  
 1" x 1 1/4"

**A45J**  
 Paint Grade  
 Foxx Lintel  
 1" x 4 1/2"

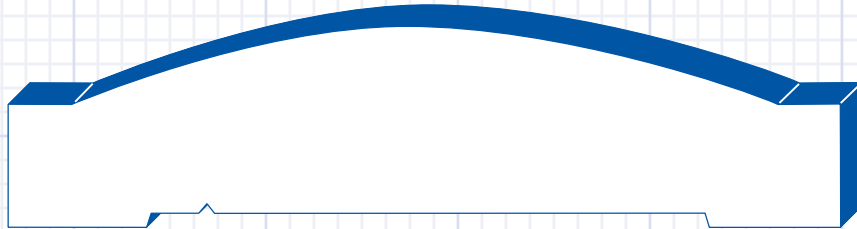

A45J

**A46J**  
 Paint Grade  
 Lintel Stop  
 1/2" x 1 1/2"

**A47J**  
 Paint Grade  
 Fluted Casing  
 3/4" x 3 1/2"

**A48J**  
 Paint Grade  
 Reed Casing  
 3/4" x 3 1/4"

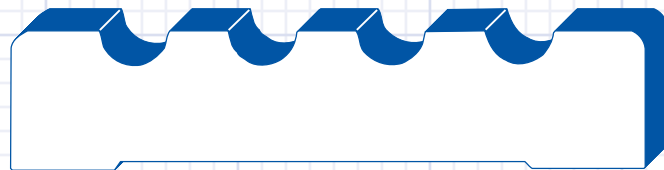

A47J

**A49J**  
 Paint Grade  
 Sir Ivor Casing  
 1" x 3 1/2"

**A49R**  
 Redwood/ Red Cedar  
 Sir Ivor Casing  
 1" x 3 1/2"

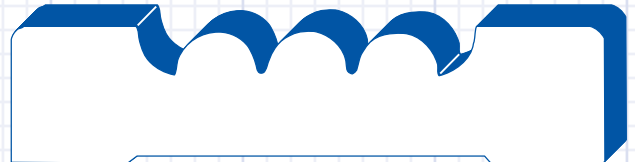

A48J

**A50J**  
 Paint Grade  
 Streamline Casing  
 1 1/16" x 1 5/8"

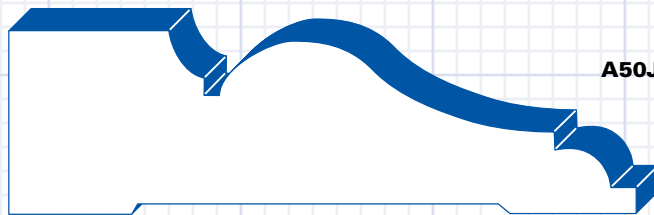

A49J  
 A49R

**A55J**  
 Paint Grade  
 Fluted Casing  
 1" x 5 1/2"

**A55R**  
 Redwood/Red Cedar  
 Fluted Casing  
 1" x 5 1/2"



A50J

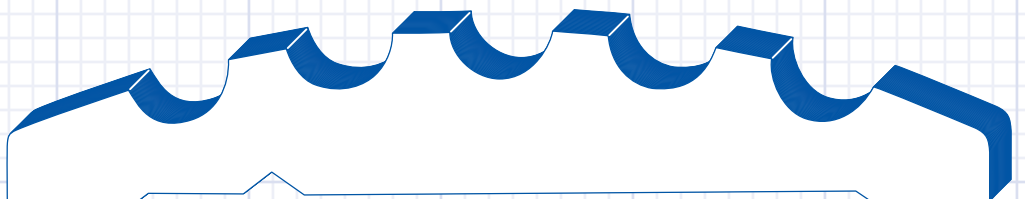

A55J  
 A55R

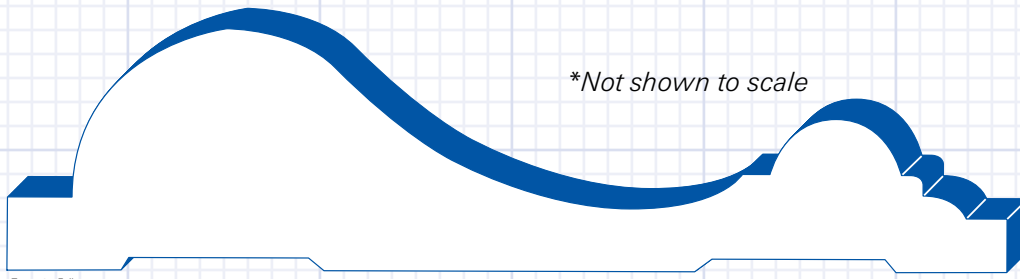

A56J\*

*\*Not shown to scale*

**A56J\***  
**Paint Grade**  
 Casing  
 $1\frac{3}{8}'' \times 5\frac{3}{4}''$



A57J

**A57J**  
**Paint Grade**  
 Casing  
 $1\frac{3}{16}'' \times 4\frac{1}{2}''$



A58J

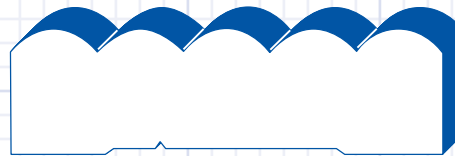

A59J

**A58J**  
**Paint Grade**  
 Clam Shell Casing  
 $1\frac{1}{2}'' \times 2\frac{1}{4}''$

**A59J**  
**Paint Grade**  
 Casing  
 $\frac{5}{8}'' \times 2\frac{7}{16}''$

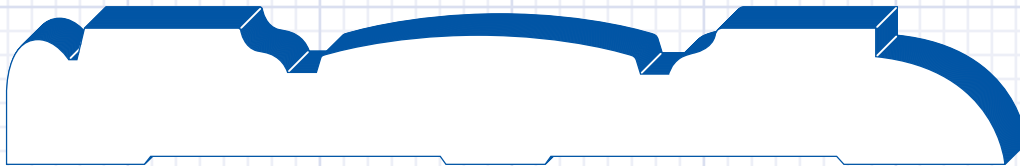

A60J

**A60J**  
**Paint Grade**  
 Victorian Casing  
 $1\frac{1}{16}'' \times 5\frac{1}{2}''$

**A61J**  
**Paint Grade**  
 Casing  
 $1\frac{1}{16}'' \times 5\frac{1}{2}''$

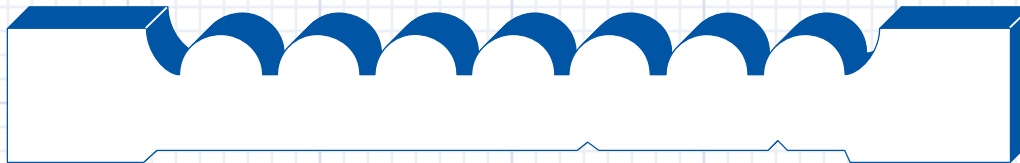

A61J  
 A61R

**A61R**  
**Redwood/Red Cedar**  
 Casing  
 $1\frac{1}{16}'' \times 5\frac{1}{2}''$

**A62J**  
**Paint Grade**  
 Gwynn Casing  
 $1\frac{1}{16}'' \times 3\frac{3}{8}''$

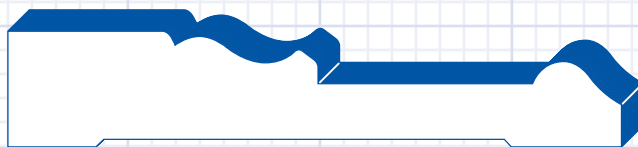

A62J

**A64J**  
**Paint Grade**  
 Bevel Casing  
 $1\frac{3}{16}'' \times 2\frac{1}{2}''$

**A65J**  
**Primed Paint Grade**  
 Notched Kerf Casing  
 $1\frac{1}{16}'' \times 2\frac{1}{2}''$

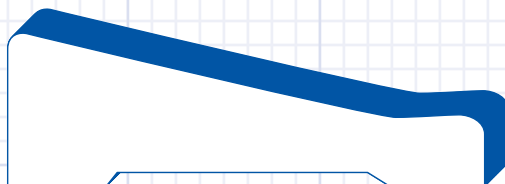

A64J



A65J

*\*Not shown to scale*

**A242**  
Paint Grade  
Moulded Casing  
*5/8" x 3 1/4"*

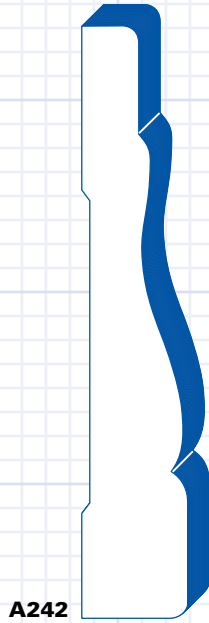

A242

**A1492J**  
Paint Grade  
Meridian Casing  
*5/8" x 2 1/4"*

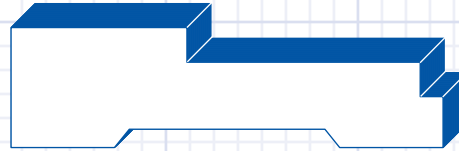

A1492J

**A1493J**  
Paint Grade  
Meridian Casing  
*7/8" x 3 7/16"*

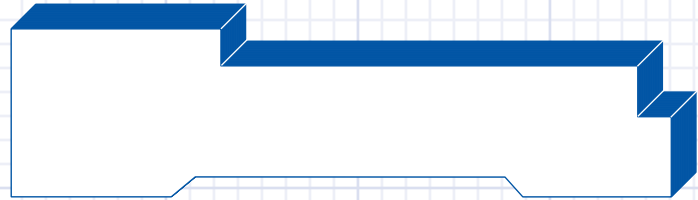

A1493J

**L1**  
Oak  
Casing  
*5/8" x 2 1/2"*

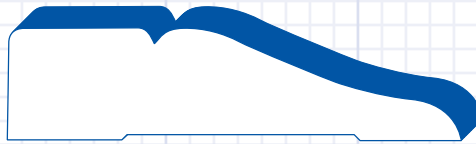

L1

**L108**  
Oak  
OG Casing  
*3/4" x 2 1/2"*

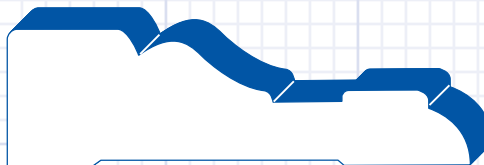

L108

**L110**  
Oak  
OG Moulded Casing  
*3/4" x 3 1/4"*

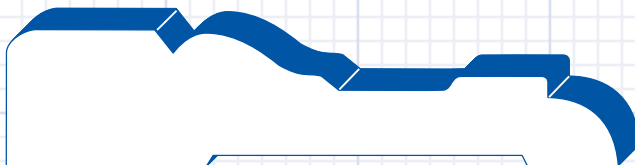

L110

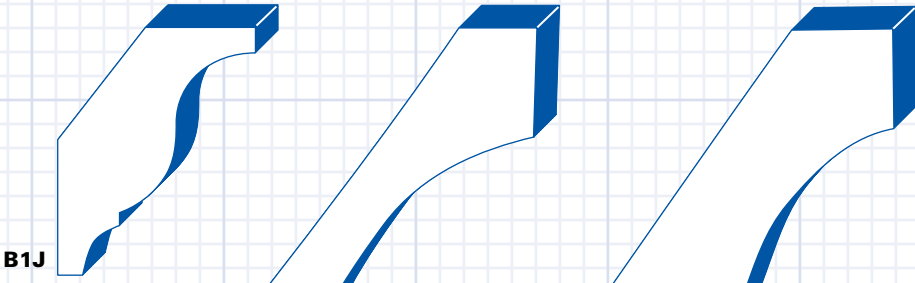

**B1J**

**B1J**  
Paint Grade  
Crown Moulding  
1 5/8"

**B2**  
Redwood/Red Cedar  
CAH Crown Moulding  
5 1/4"

**B2J**  
Paint Grade  
Crown Moulding  
5 1/4"

**B3J**  
Paint Grade  
Crown Moulding  
3 5/8"

**B3R**  
Redwood/Red Cedar  
Crown Moulding  
3 5/8"

**B4J**  
Paint Grade  
Crown Moulding  
2 3/4"

**B5J**  
Paint Grade  
Cove Moulding  
1 3/4"

**B6**  
Pine  
Cove Moulding  
3/4" X 3/4"

**B6R**  
Redwood/Red Cedar  
Cove Moulding  
3/4" X 3/4"

**B8**  
Redwood/Red Cedar  
Bed Moulding  
2 3/4"

**B9**  
Redwood/Red Cedar  
Header Cap  
1 1/2" X 2 1/4"

**B10J**  
Paint Grade  
Picture Moulding  
1 1/16" X 2 1/2"

**B2  
B2J**

**B3J  
B3R**

**B5J**

**B4J**

**B6  
B6R**

**B8**

**B9**

**B10J**

**B11J**  
**Paint Grade**  
 Picture Moulding  
 1 1/16" x 1 3/4"

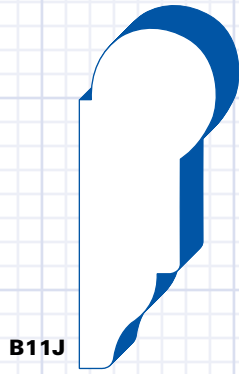

**B11J**

**B12**  
**Redwood/Red Cedar**  
 "Beaded" Cove  
 1 5/16" x 2 1/8"



**B12**

**B13J**  
**Paint Grade**  
 Crown  
 1 1/16" x 4 1/4"

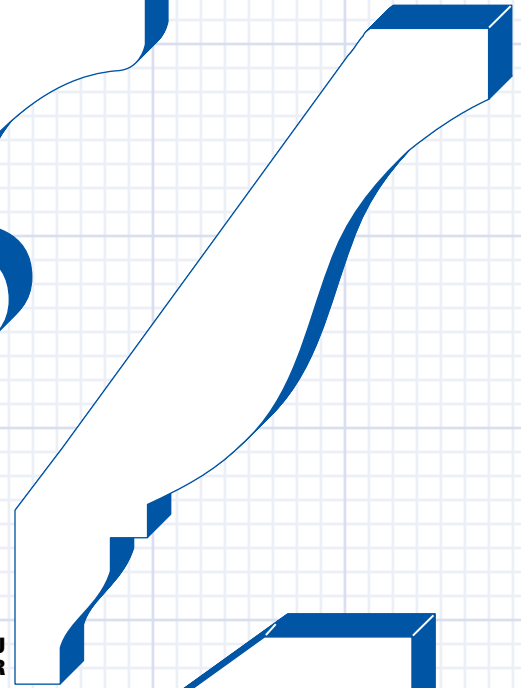

**B13J**  
**B13R**

**B13R**  
**Redwood/Red Cedar**  
 Crown  
 1 1/16" x 4 1/4"



**B13R**

**B16**  
**Pine**  
 Cove Moulding  
 1/2" x 1/2"

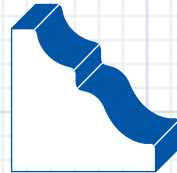

**B16**

**B17**  
**Pine**  
 Solid Crown  
 9/16" x 3/4"

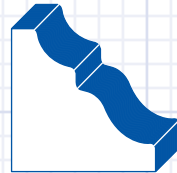

**B17**

**B18J**  
**Redwood/Red Cedar**  
 Ovolo Crown  
 5 1/2"

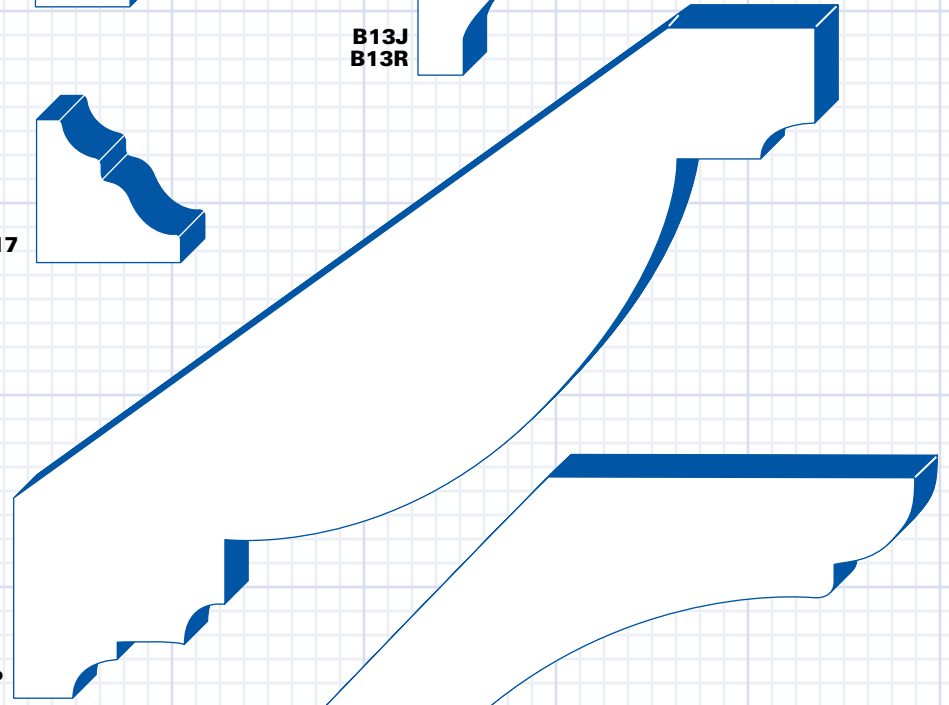

**B18J**  
**B18P**

**B18P**  
**Paint Grade**  
 Ovolo Crown  
 5 1/2"

**B19J**  
**Redwood/Red Cedar**  
 Cove  
 5 1/2"

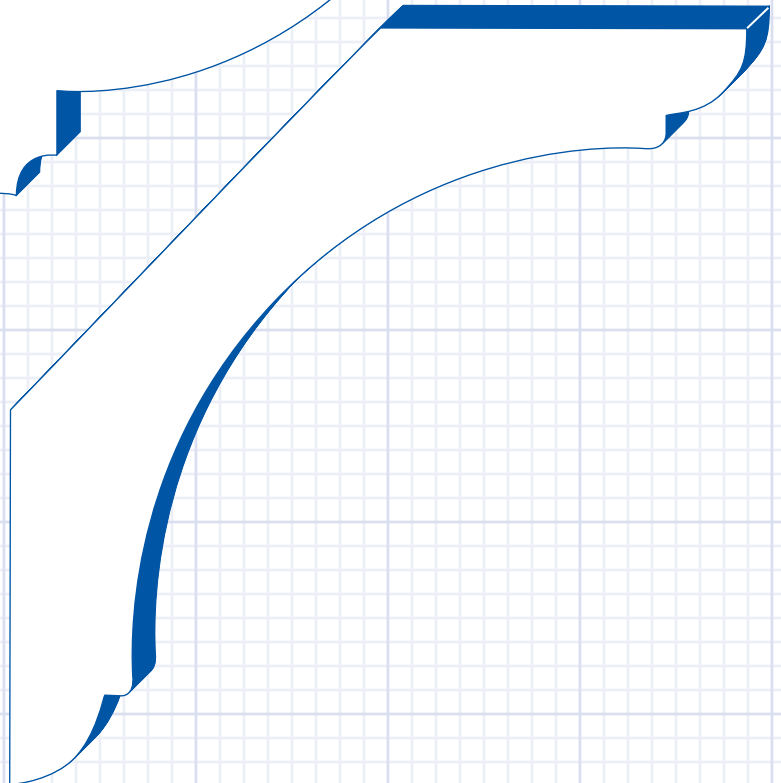

**B19J**  
**B19P**

**B19P**  
**Pine**  
 Cove  
 5 1/2"

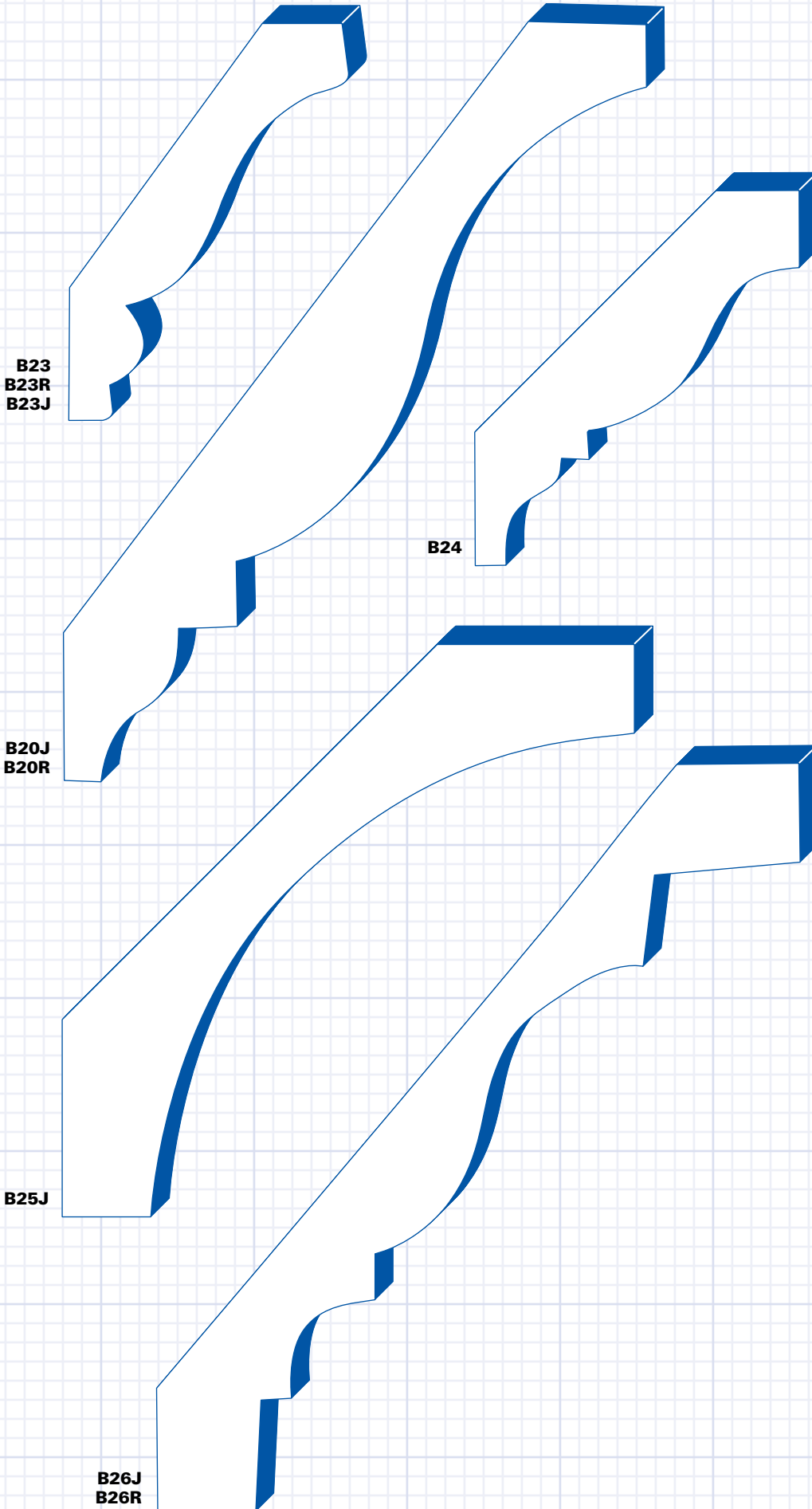

**B23  
B23R  
B23J**

**B20J  
B20R**

**B25J**

**B26J  
B26R**

**B24**

**B20J**  
Paint Grade  
Crown  
6 1/4"

**B20R**  
Redwood/Red Cedar  
Crown  
6 1/4"

**B23**  
Red Knot Pine  
Crown  
3 1/8"

**B23J**  
Paint Grade  
Crown  
3 1/8"

**B23R**  
Redwood/Red Cedar  
Crown  
3 1/8"

**B24**  
VG Fir  
Crown Moulding  
3 1/4"

**B25J**  
Paint Grade  
Cove  
5 1/4"

**B26J**  
Paint Grade  
Triple Crown  
6 3/8"

**B26R**  
Redwood/Red Cedar  
Triple Crown  
6 3/8"

**B27J**  
Paint Grade  
Cornice Crown  
5<sup>3</sup>/<sub>8</sub>"

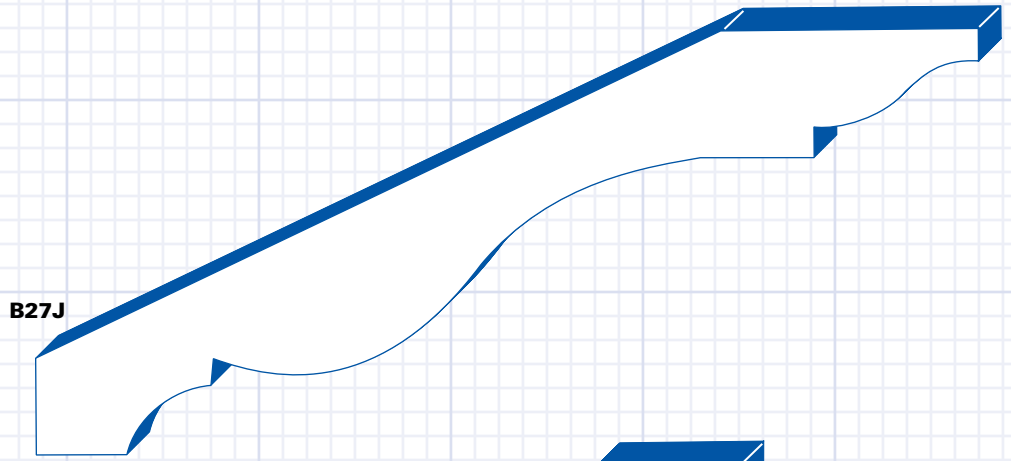

**B28J**  
Paint Grade  
Cove  
3<sup>1</sup>/<sub>2</sub>"

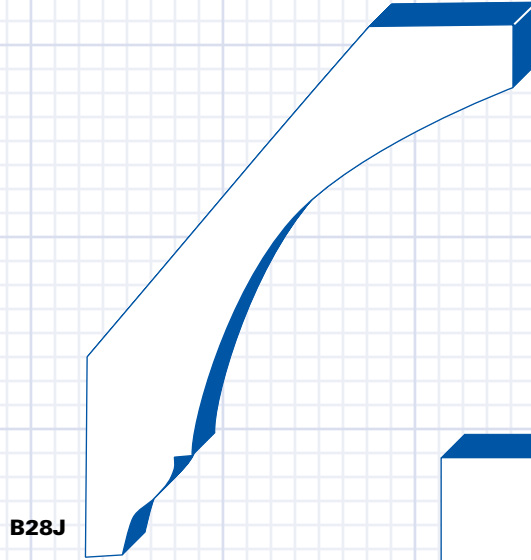

**B29J**  
Paint Grade  
Alydar Crown  
1" x 1<sup>1</sup>/<sub>2</sub>"

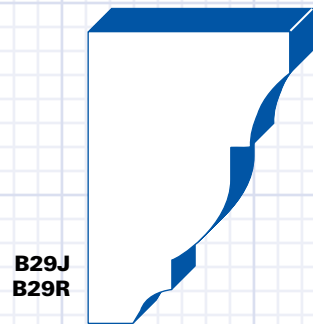

**B29R**  
Redwood/Red Cedar  
Alydar Crown  
1" x 1<sup>1</sup>/<sub>2</sub>"

**B30J**  
Paint Grade  
Bed Moulding  
1<sup>7</sup>/<sub>8</sub>"

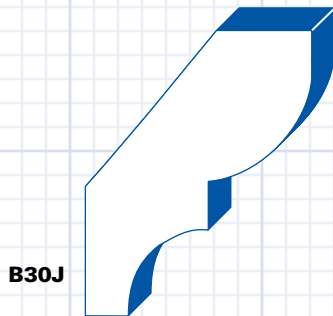

**B32J**  
Paint Grade  
Cove  
2<sup>1</sup>/<sub>2</sub>"

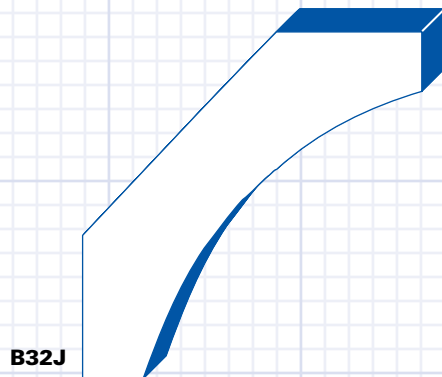

**B33J**  
Paint Grade  
Cove  
3<sup>1</sup>/<sub>2</sub>"

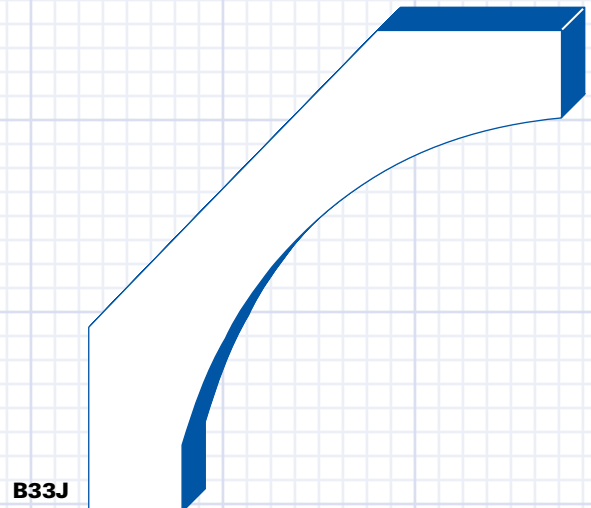



**B34J**  
Paint Grade  
Plate Rail  
1" x 3 1/2"

B34J

**B35J**  
Paint Grade  
Crown  
3/4" x 2 1/2"



B35J

**B36**  
Redwood/Red Cedar  
Ballymoss Cove  
1 1/2" x 1 1/2"

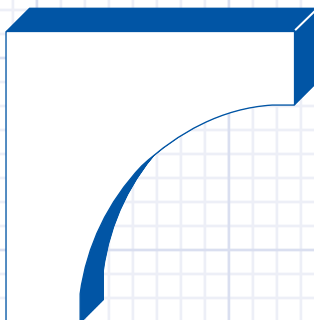

B36

**B38**  
Redwood/Red Cedar  
Piggott Crown  
1 1/2" x 1 1/2"

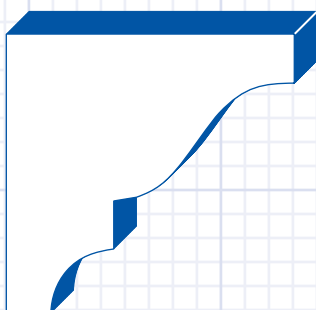

B38

**B39**  
Redwood/Red Cedar  
Cove  
1" x 1"

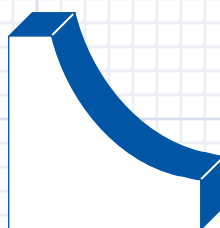

B39  
B39J

**B39J**  
Paint Grade  
Cove  
1" x 1"

**B40**  
Paint Grade  
Door Hood  
1 3/4" x 3 1/8"

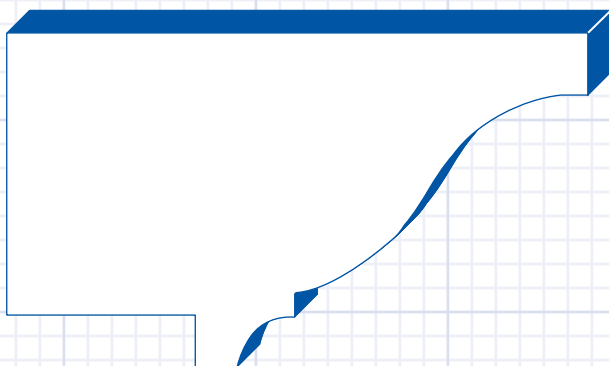

B40

**B45**  
Redwood/Red Cedar  
Crown  
1 3/8" x 2 11/16"

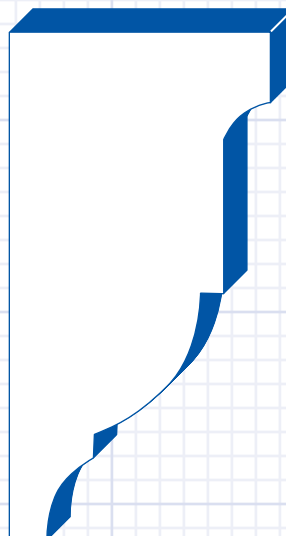

B45



**B47J**

Paint Grade

Crown

2<sup>7</sup>/<sub>16</sub>"

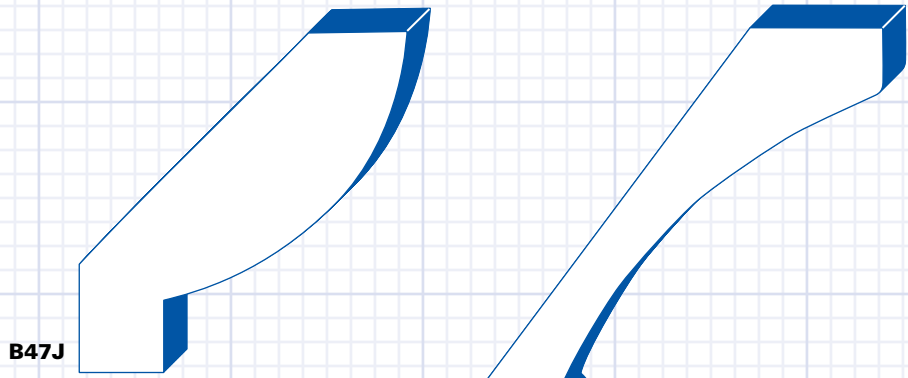

**B49J**

Paint Grade

"Beaded" Crown

4<sup>9</sup>/<sub>16</sub>"

B47J

B49J

**B50J**

Paint Grade

Cove

3/4" X 2<sup>9</sup>/<sub>16</sub>"

**B51J**

Paint Grade

Crown / Cove

1<sup>5</sup>/<sub>16</sub>" X 5<sup>5</sup>/<sub>8</sub>"

**B52J**

Paint Grade

Crown / Cove

1<sup>5</sup>/<sub>16</sub>" X 7<sup>1</sup>/<sub>4</sub>"

B50J

B51J

B52J

**L15**  
Oak  
Cove  
3/4"

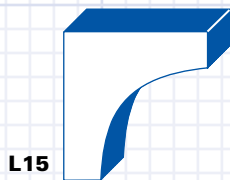

**L23**  
Oak  
Crown  
2 11/16"

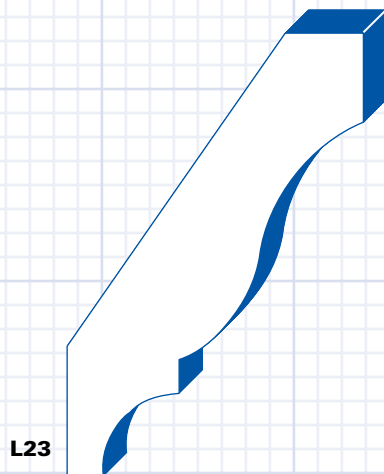

**L24**  
Oak  
Crown  
3 1/4"

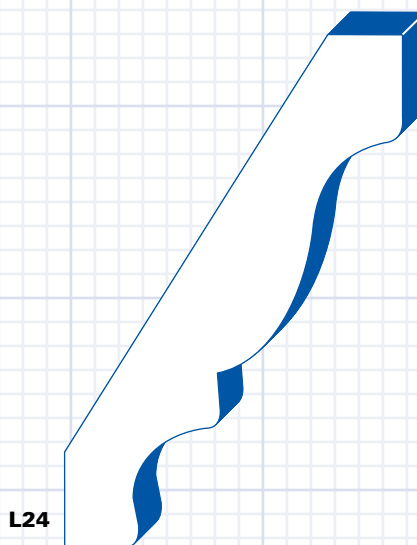

**C1J**  
**Paint Grade**  
 R/E Base  
 $\frac{1}{2}'' \times 5\frac{1}{2}''$

**C2J**  
**Paint Grade**  
 Reverse Base  
 $\frac{1}{2}'' \times 3\frac{1}{4}''$

**C3J**  
**Paint Grade**  
 Reverse Base  
 $\frac{3}{8}'' \times 2\frac{1}{4}''$

**C6J**  
**Paint Grade**  
 Panel Cap  
 $\frac{11}{16}'' \times 2\frac{1}{4}''$

**C6R**  
**Redwood/  
 Red Cedar**  
 Panel Cap  
 $\frac{11}{16}'' \times 2\frac{1}{4}''$

**C7J**  
**Paint Grade**  
 Cove Cap  
 $\frac{3}{4}'' \times 2\frac{9}{16}''$

**C8**  
**Pine Coronado**  
 Base Cap  
 $\frac{11}{16}'' \times 1\frac{3}{8}''$

**C8R**  
**Redwood/  
 Red Cedar**  
 Base Cap  
 $\frac{11}{16}'' \times 1\frac{3}{8}''$

**C9J**  
**Paint Grade**  
 Base Cap  
 $\frac{3}{4}'' \times 2\frac{9}{16}''$

**C12J**  
**Paint Grade**  
 Moulded Base  
 $\frac{5}{8}'' \times 7\frac{1}{8}''$

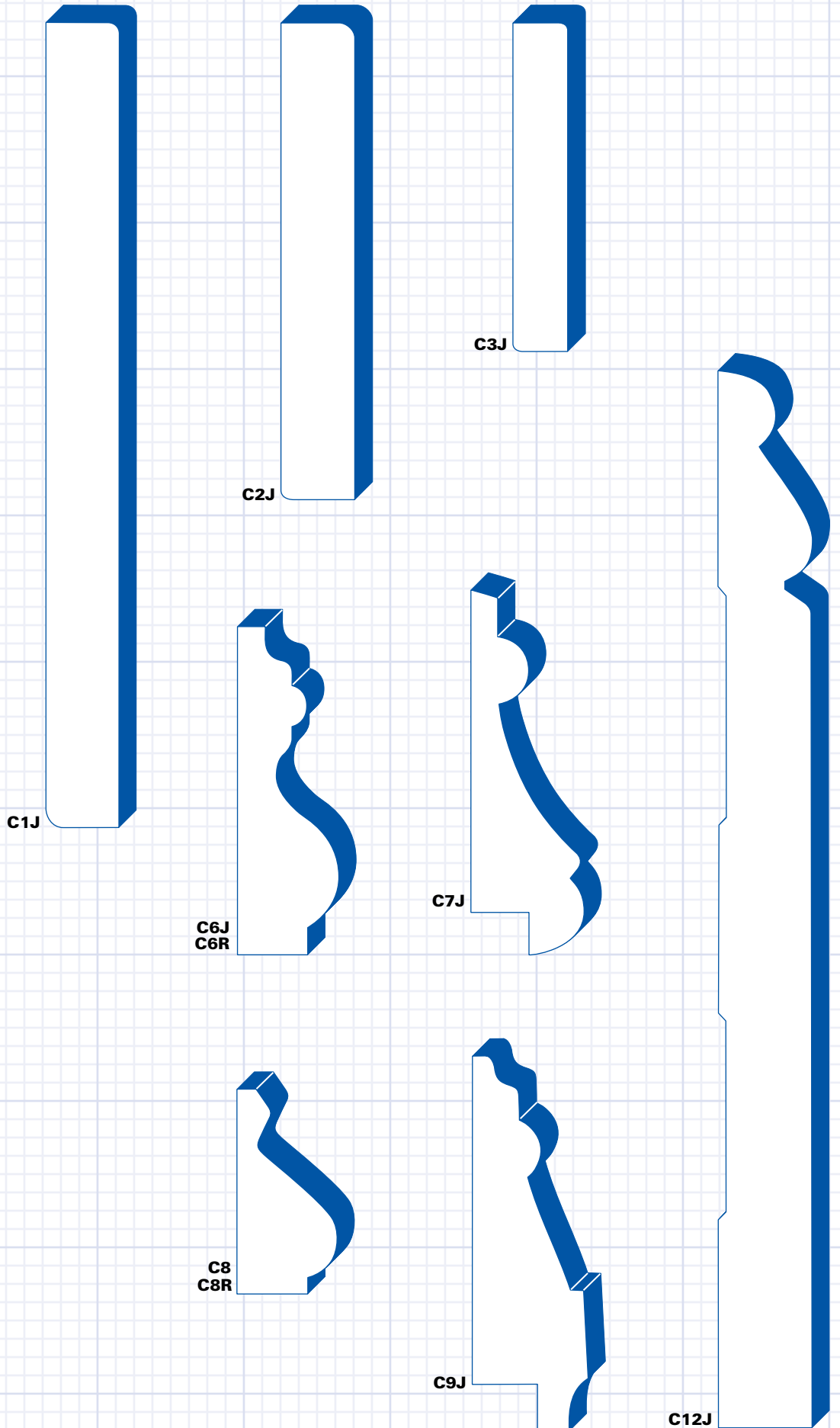

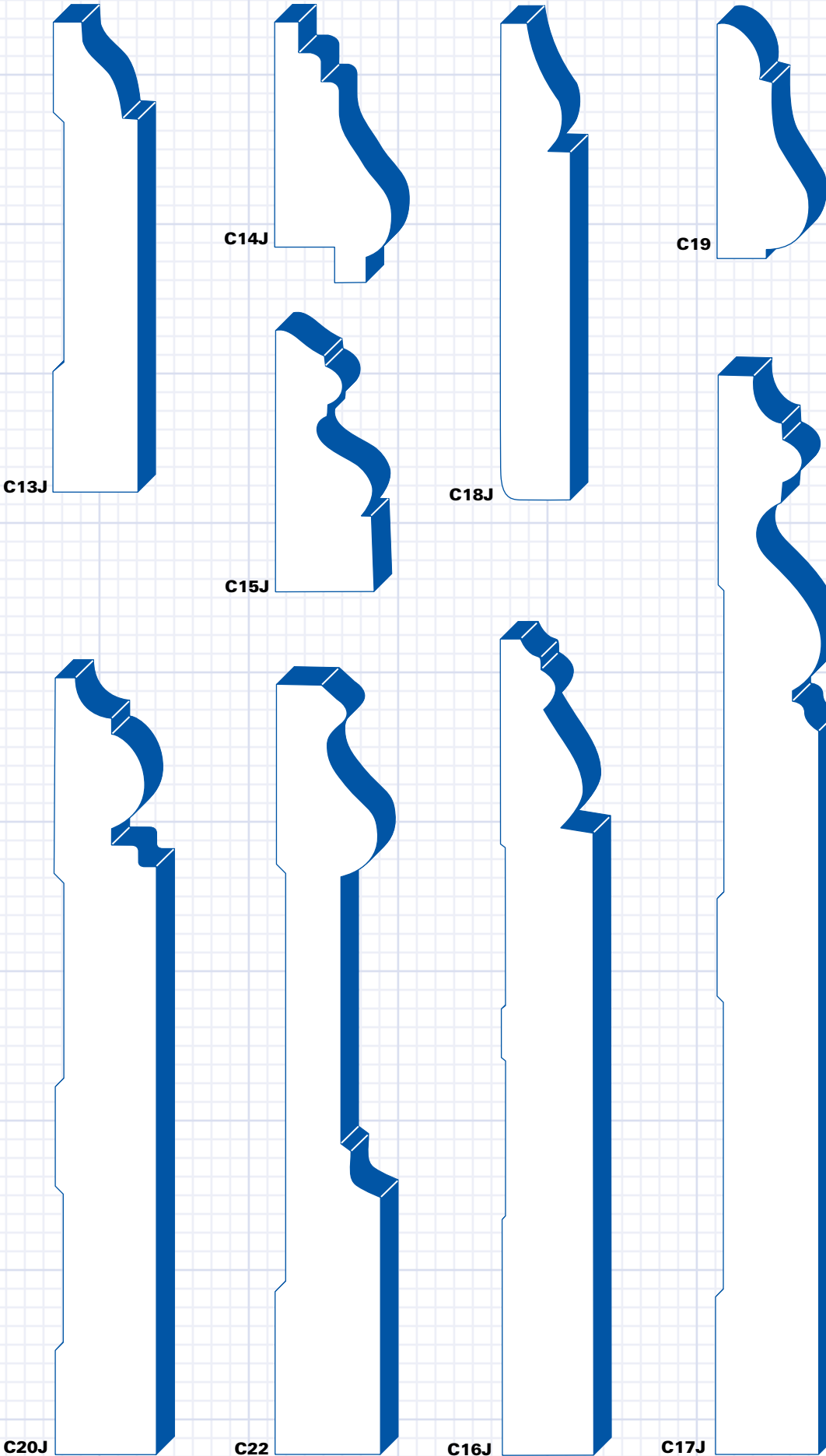

**C13J**  
**Paint Grade**  
 Coronado Base  
 $9\frac{1}{16}'' \times 3\frac{1}{4}''$

**C14J**  
**Paint Grade**  
 Fulton Cap  
 $13\frac{3}{16}'' \times 1\frac{3}{4}''$

**C15J**  
**Paint Grade**  
 Gallo Base Cap  
 $11\frac{1}{16}'' \times 1\frac{3}{4}''$

**C16J**  
**Paint Grade**  
 Base  
 $5\frac{1}{8}'' \times 5\frac{1}{2}''$

**C17J**  
**Paint Grade**  
 Broadway Base  
 $11\frac{1}{16}'' \times 7\frac{1}{8}''$

**C18J**  
**Pine Solid**  
 First Base  
 $1\frac{1}{2}'' \times 3\frac{3}{16}''$

**C19**  
**Paint Grade**  
 Kevin Cap  
 $9\frac{1}{16}'' \times 1\frac{9}{16}''$

**C20J**  
**Paint Grade**  
 Wilson Base  
 $5\frac{1}{8}'' \times 5\frac{3}{16}''$

**C22**  
**Pine Red Knot**  
 Country Base  
 $5\frac{1}{8}'' \times 5\frac{3}{16}''$

**C23J**  
**Paint Grade**  
 Coronado Base  
*9/16" x 5 1/2"*



**C23J**

**C24J**  
**Paint Grade**  
 Moulded Base  
*9/16" x 4 1/2"*



**C24J**

**C27J**  
**Paint Grade**  
 Base Cap  
*1 1/16" x 2 7/16"*



**C27J**

**C29**  
**Solid Fir**  
 VG Base  
*1 1/16" x 5"*

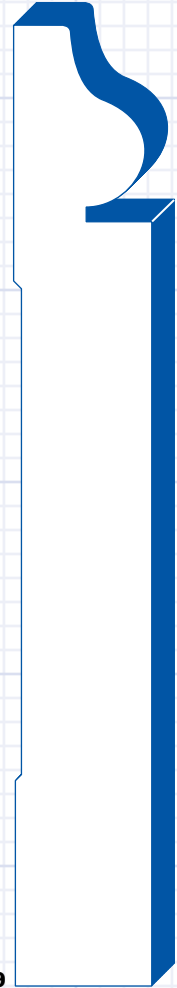

**C29**

**C31J**  
**Paint Grade**  
 Base Shoe  
*5/8" x 1"*



**C31J**

**C32J**  
**Paint Grade**  
 Longdon Cap  
*1" x 1 3/4"*

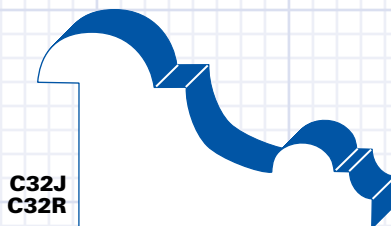

**C32J**  
**C32R**

**C32R**  
**Redwood/  
 Red Cedar**  
 Longdon Cap  
*1" x 1 3/4"*

**C36J**  
**Paint Grade**  
 Cap  
*3/4" x 1 3/4"*

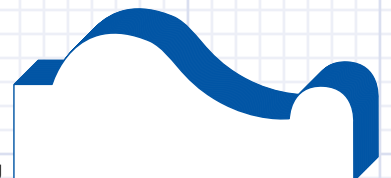

**C36J**



**C38J\***

*\*Not shown to scale*

**C37J**  
**Paint Grade**  
 Base  
 $\frac{3}{4}'' \times 7\frac{1}{8}''$

**C38J\***  
**Paint Grade**  
 Base  
 $\frac{3}{4}'' \times 5\frac{7}{16}''$

**C39J**  
**Paint Grade**  
 Base Cap  
 $\frac{5}{8}'' \times 2\frac{1}{16}''$

**C40J\***  
**Paint Grade**  
 Chalmers Base  
 $\frac{5}{8}'' \times 5\frac{1}{2}''$

**C42J**  
**Paint Grade**  
 Cap  
 $\frac{1}{2}'' \times \frac{3}{4}''$

**C42R**  
**Redwood/Red Cedar**  
 Cap  
 $\frac{1}{2}'' \times \frac{3}{4}''$

**C43J**  
**Paint Grade**  
 Base / Casing  
 $\frac{13}{16}'' \times 5\frac{1}{4}''$

**C54J**  
**Paint Grade**  
 Notched Kerf Base  
 $\frac{9}{16}'' \times 4\frac{1}{2}''$

**C55J\***  
**Paint Grade**  
 Notched Kerf Base  
 $\frac{9}{16}'' \times 5\frac{1}{2}''$

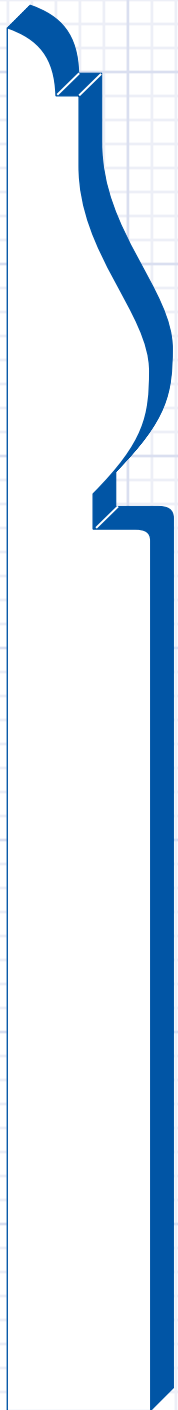

**C37J**

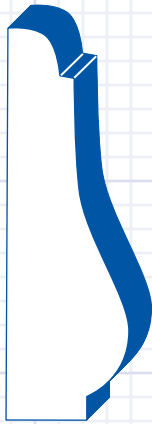

**C39J**



*\*Not shown to scale*

**C40J\***



**C42J**  
**C42R**

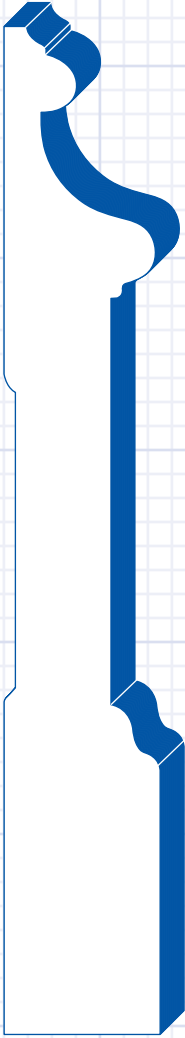

**C43J**



**C54J**



**C55J\***

*\*Not shown to scale*

**L10S**

**Oak Coronado**  
Base  
*1 1/2" x 4 1/4"*



**L11S**

**Oak Coronado**  
Base  
*1 1/2" x 3 1/4"*



L16

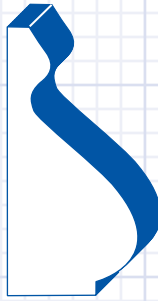

**L16**

**Oak Coronado**  
Cap  
*1 1/16" x 1 3/8"*

**L17**

**Oak**  
Base Cap  
*1 1/2" x 3/4"*

L17



**L25**

**Oak**  
Bullnose and Cove  
*1 1/8" x 1 55/64"*

L11S

**L29**

**Oak**  
Picture Moulding  
*1 3/16" x 1 1/8"*

L10S

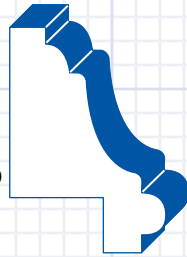

L29

**L31**

**Oak**  
Picture Moulding  
*1" x 2"*

L31

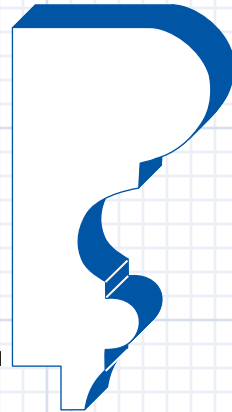

**L59**

**Oak**  
Reversible Base  
*3/8" x 2 1/4"*

L59



**L106**

**Oak**  
OG Moulded Base  
*5/8" x 3 1/4"*

L25

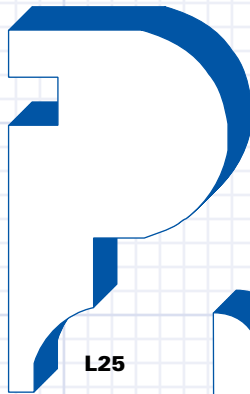

**L120**

**Oak**  
Reversible Base  
*1 1/2" x 3 1/4"*

L106



L120



5514

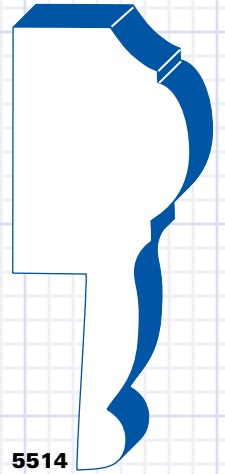



**D1**  
Pine  
R/E Stop  
 $\frac{3}{8}'' \times 1 \frac{1}{8}''$

**D2**  
Pine  
R/E Stop  
 $\frac{3}{8}'' \times 1 \frac{3}{8}''$



**D2J**  
Paint Grade  
Stop  
 $\frac{3}{8}'' \times 1 \frac{3}{8}''$

**D3J**  
Paint Grade  
R/E Stop  
 $\frac{3}{8}'' \times 1 \frac{5}{8}''$



**D4**  
Pine  
Victorian Stop  
 $\frac{1}{2}'' \times 1 \frac{3}{8}''$

**D5**  
Pine  
Parting Bead  
 $\frac{3}{8}'' \times \frac{3}{4}''$

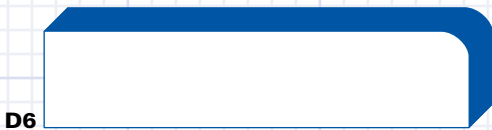

**D6**  
Pine Paint Grade  
R/E Stop  
 $\frac{1}{2}'' \times 2 \frac{1}{4}''$

**D8**  
Pine  
Glass Bead  
 $\frac{3}{8}'' \times \frac{3}{8}''$

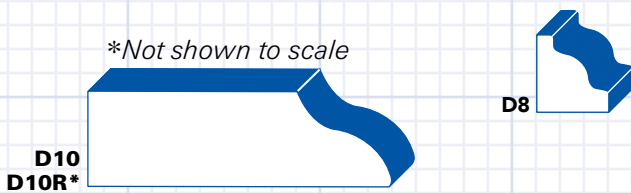

**D9**  
Pine Glass Bead  
OG Stop  
 $\frac{1}{2}'' \times \frac{5}{8}''$

**D10**  
Pine  
OG Stop S4S  
 $\frac{1}{2}'' \times 1 \frac{5}{8}''$

**D10R\***  
Redwood/Cedar  
OG OS Stop S4S  
 $\frac{1}{2}'' \times 1 \frac{1}{2}''$

**D11**  
Redwood  
Square Edge Stop  
 $\frac{1}{2}'' \times 1 \frac{1}{2}''$



**D12J**  
Paint Grade  
Colonial Stop  
 $\frac{3}{8}'' \times 1 \frac{3}{8}''$

**D15**  
Fir  
Panel Glass Bead  
 $\frac{3}{8}'' \times \frac{1}{2}''$

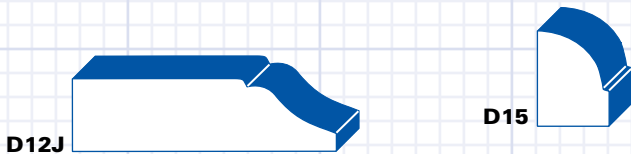

**D16**  
Redwood/Red Cedar  
Stop  
 $1'' \times 2 \frac{1}{2}''$

**D16F**  
Douglas Fir  
Stop  
 $1'' \times 2 \frac{1}{2}''$

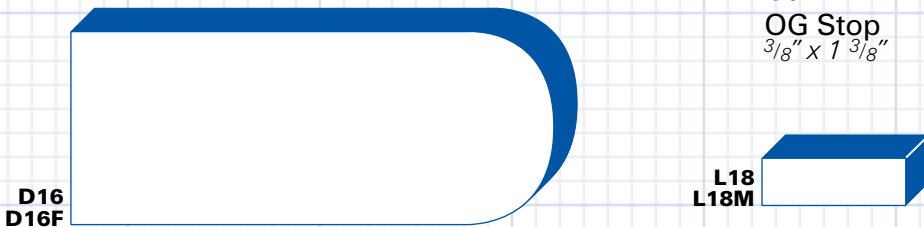

**L18**  
Oak  
Edge  
 $\frac{1}{4}'' \times \frac{3}{4}''$

**L18M**  
Maple  
Edge  
 $\frac{1}{4}'' \times \frac{3}{4}''$

**L19**  
Oak  
OG Stop  
 $\frac{3}{8}'' \times 1 \frac{3}{8}''$

**L20**  
Oak  
R/E Stop  
 $\frac{7}{16}'' \times 1 \frac{3}{16}''$



*\*Not shown to scale*



**E1J**  
**Paint Grade**  
 Chair Rail  
 9/16" x 2 1/2"

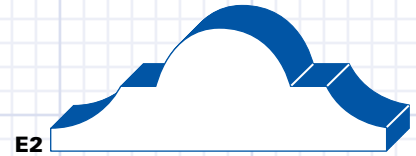

**E2**  
**Pine**  
 Flat Astragal  
 5/8" x 1 3/4"

**E3J**  
**Paint Grade**  
 Panel Moulding  
 1 1/16" x 1 3/8"

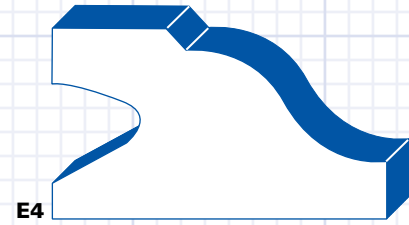
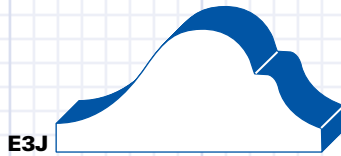

**E4**  
**Redwood/Red Cedar**  
 Victorian Stucco  
 1" x 1 3/4"

**E5**  
**Pine**  
 Panel Moulding  
 5/8" x 1"

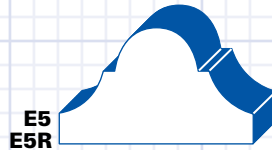

**E5R**  
**Redwood/Red Cedar**  
 Panel Moulding  
 5/8" x 1"

**E6J**  
**Redwood/Red Cedar**  
 Shingle Moulding  
 1 1/16" x 1 9/16"

**E7**  
**Redwood/Red Cedar**  
 Stucco  
 1" x 1 9/16"

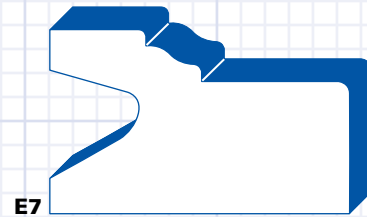

**E9**  
**Pine**  
 Panel Strip  
 1/2" x 1 3/8"

**E10J**  
**Paint Grade**  
 Panel Moulding  
 1 1/16" x 2 7/16"

**E10R**  
**Redwood/Cedar**  
 Panel Moulding  
 1 1/16" x 2 7/16"

**E12J**  
**Paint Grade**  
 Colonial Moulding  
 1" x 3"

**E13J**  
**Paint Grade**  
 Panel Cap  
 3/4" x 1 3/8"

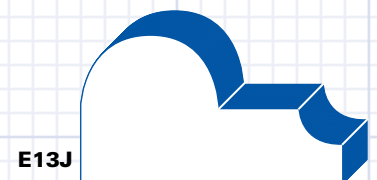
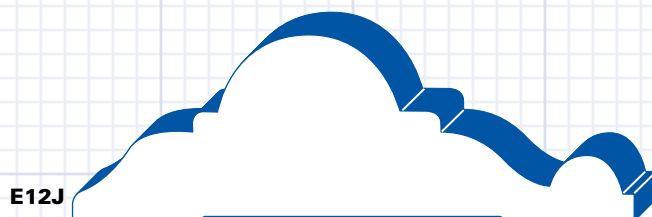
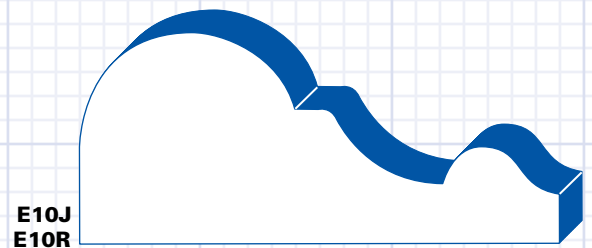



**E14J**  
Redwood/Red Cedar  
Dublin Stucco  
1" x 3"

**E15J**  
Redwood/Red Cedar  
Brick Moulding  
1" x 2"

**E15K**  
Redwood/Red Cedar  
Brick Moulding (Keyed)  
1" x 2"

**E16**  
Redwood/Red Cedar  
Garage Stop  
1 1/16" x 2 3/8"

**E17K**  
Redwood/Red Cedar  
Brick Moulding (Keyed)  
1 1/4" x 2"

**E17R**  
Redwood/Red Cedar  
Brick Moulding  
1 1/4" x 2"

**E20-4**  
Redwood/Red Cedar  
Bevel Cap  
1 3/8" x 3 1/2"

**E20-6J**  
Redwood/Red Cedar  
Bevel Cap  
1 3/8" x 5 1/2"

**E20-8**  
Redwood/Red Cedar  
Bevel Cap  
1 3/8" x 7 1/4"  
not shown

**E20-10**  
Redwood/Red Cedar  
Bevel Cap  
1 3/8" x 9 1/4"  
not shown

**E20-12**  
Redwood/Red Cedar  
Bevel Cap  
1 3/8" x 11 1/4"  
not shown

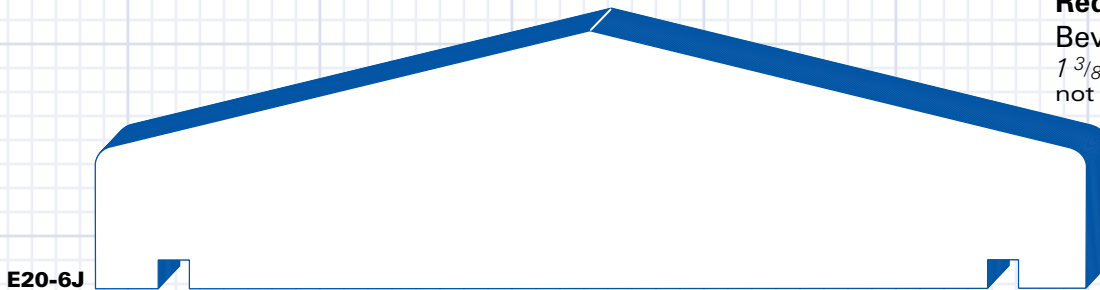
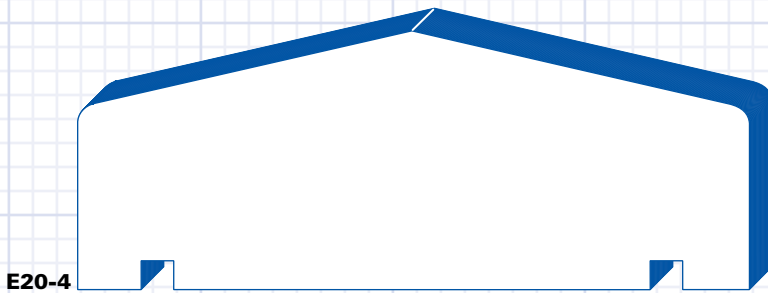
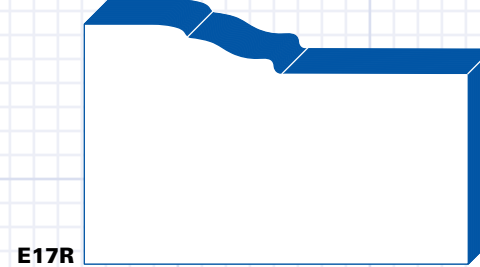
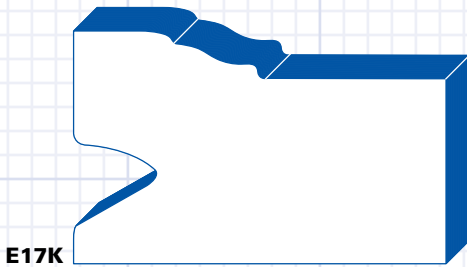
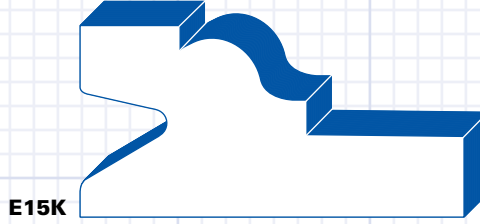
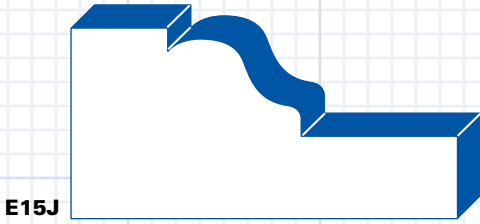

**E21J**  
**Paint Grade**  
 Panel Moulding  
 1 1/4" x 1 11/16"

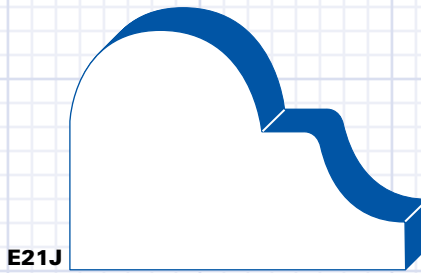

**E23J**  
**Paint Grade**  
 Band Moulding  
 5/8" x 1 7/8"

E23J

**E24J**  
**Paint Grade**  
 Band Moulding  
 1/2" x 1 1/2"



E24J

**E25**  
**Poplar**  
 Window Band  
 1 3/4" x 3 1/8"

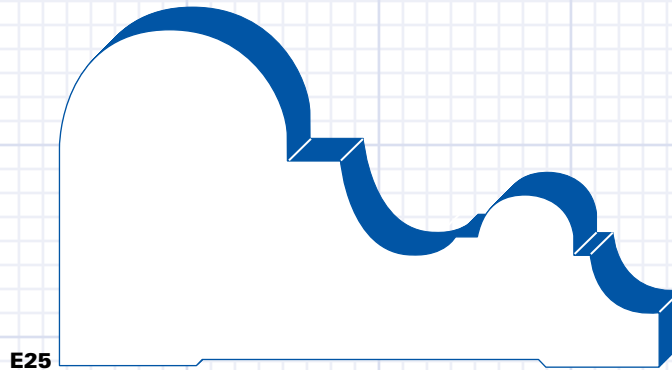

E25

**E30J**  
**Paint Grade**  
 Chair Rail  
 5/8" x 3 1/2"

**L26**  
**Oak**  
 Crown Moulding  
 3/4" x 7/8"

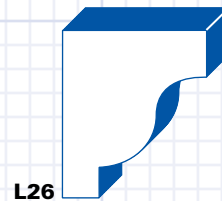

L26

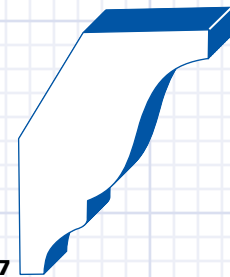

L27

**L27**  
**Oak**  
 Crown Moulding  
 1 5/8"

**L45**  
**Oak**  
 Flat Astragal  
 1 1/16" x 1 3/4"

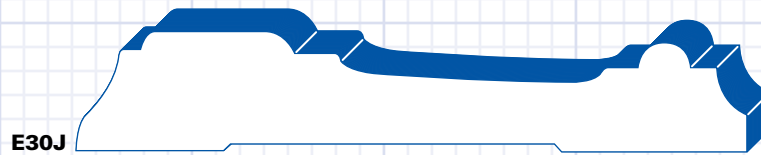

E30J

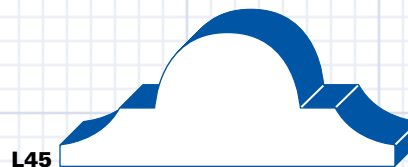

L45



F1



F2

**F1**  
Pine  
Flat Screen Moulding  
 $1/4" \times 3/4"$

**F3**  
Pine  
Square Stop  
 $1/2" \times 1/2"$

**F5**  
Pine  
Square Stop  
 $3/4" \times 3/4"$

**F7**  
Pine  
Lattice  
 $1/4" \times 1 3/4"$

**F2**  
Pine  
"Beaded" Screen Moulding  
 $1/4" \times 3/4"$

**F4**  
Pine  
Stop  
 $1/2" \times 3/4"$

**F5R**  
Redwood/Red Cedar  
Square Stop  
 $3/4" \times 3/4"$

**F7R**  
Redwood/Red Cedar  
Lattice  
 $1/4" \times 1 3/4"$

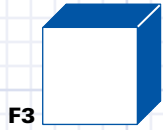

F3



F4

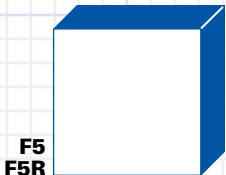

F5  
F5R



F6

**F8**  
Redwood/Red Cedar  
Resawn Batten  
 $1/4" \times 2 1/2"$

**F9**  
Redwood/Red Cedar  
Lattice  
 $1/4" \times 1 3/8"$

**F6**  
Pine  
Lattice  
 $1/4" \times 1 3/8"$



F7  
F7R

**F11**  
Pine  
Lattice  
 $2 1/4"$



F8

**L118**  
Oak  
S4S Square Stop  
 $3/4" \times 3/4"$



F9



F11

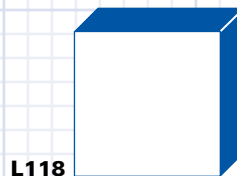

L118

**G3**  
Pine  
O/S Corner  
3/4" x 3/4"

**G5**  
Pine  
Half Round  
3/4"

**G7J**  
Paint Grade  
Half Round  
1 1/2"

**G8**  
Pine  
Quarter Round  
1/4" x 1/4"

**G10**  
Pine  
Quarter Round  
3/4" x 3/4"

**G11**  
Pine  
Quarter Round  
5/8" x 5/8"

**G12R**  
Redwood/Red Cedar  
Quarter Round  
1/2" x 1/2"

**G14**  
Fir  
Closet Pole  
1 3/8"

**G16J**  
Paint Grade  
Quarter Round  
1" x 1"

**G18**  
Redwood/Red Cedar  
Corner Bead  
5/8" x 7/8"

**G4**  
Pine  
Half Round  
1/2"

**G6**  
Pine  
Half Round  
1"

**G7R**  
Redwood/Red Cedar  
Half Round  
1 1/2"

**G9**  
Pine  
Quarter Round  
3/8" x 3/8"

**G10R**  
Redwood/Red Cedar  
Quarter Round  
3/4" x 3/4"

**G12**  
Pine  
Quarter Round  
1/2" x 1/2"

**G13**  
Redwood/Red Cedar  
Quarter Round  
1 1/2"

**G16**  
Redwood/Red Cedar  
Quarter Round  
1" x 1"

**G17**  
Pine  
Outside Corner  
1" x 1"

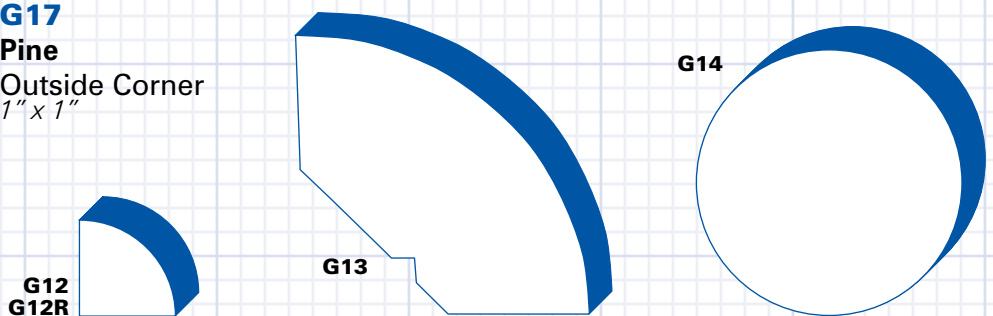
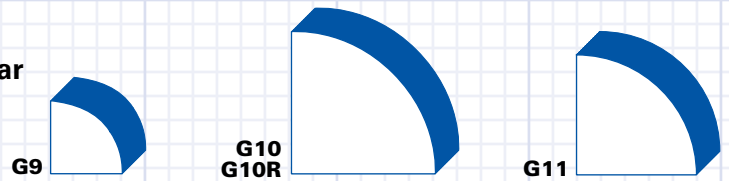
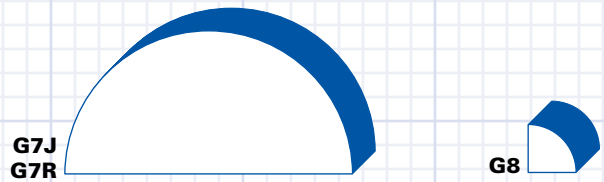
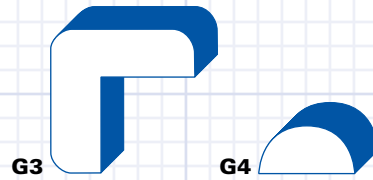

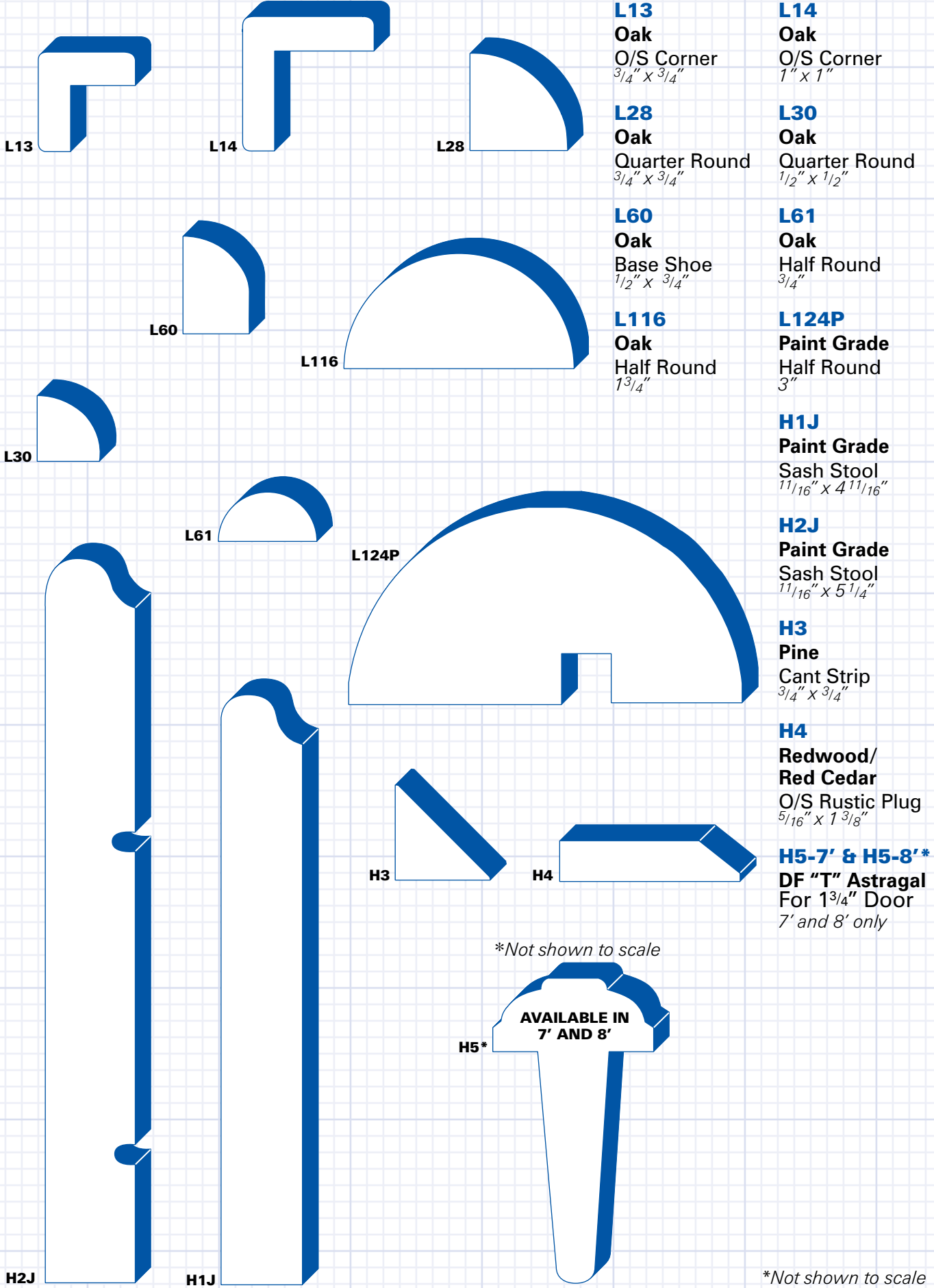

**L13**  
Oak  
O/S Corner  
3/4" X 3/4"

**L14**  
Oak  
O/S Corner  
1" X 1"

**L28**  
Oak  
Quarter Round  
3/4" X 3/4"

**L30**  
Oak  
Quarter Round  
1/2" X 1/2"

**L60**  
Oak  
Base Shoe  
1/2" X 3/4"

**L61**  
Oak  
Half Round  
3/4"

**L116**  
Oak  
Half Round  
1 3/4"

**L124P**  
Paint Grade  
Half Round  
3"

**H1J**  
Paint Grade  
Sash Stool  
1 1/16" X 4 1/16"

**H2J**  
Paint Grade  
Sash Stool  
1 1/16" X 5 1/4"

**H3**  
Pine  
Cant Strip  
3/4" X 3/4"

**H4**  
Redwood/  
Red Cedar  
O/S Rustic Plug  
5/16" X 1 3/8"

**H5-7' & H5-8'\***  
DF "T" Astragal  
For 1 3/4" Door  
7' and 8' only

*\*Not shown to scale*

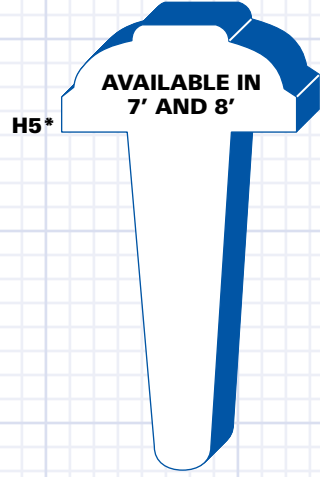

*\*Not shown to scale*

**H6J**  
 Paint Grade  
 Hook Strip  
 1<sup>1</sup>/<sub>16</sub>" x 4<sup>1</sup>/<sub>2</sub>"

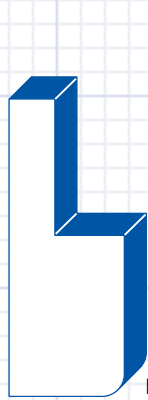

H8J

**H7**  
 Redwood/  
 Red Cedar  
 O/S Rustic Plug  
 5<sup>1</sup>/<sub>16</sub>" x 1<sup>3</sup>/<sub>8</sub>"

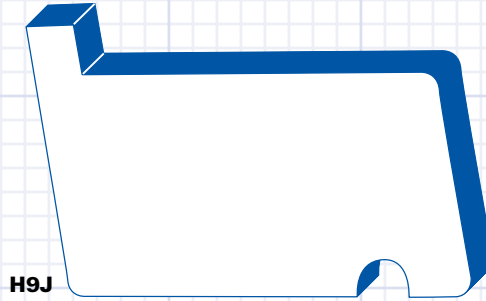

H9J

**H8J**  
 Paint Grade  
 Shelf Cleat  
 1<sup>1</sup>/<sub>16</sub>" x 1<sup>1</sup>/<sub>2</sub>"



H7

**H9J**  
 Redwood/Red Cedar  
 Water Table  
 1<sup>1</sup>/<sub>2</sub>" x 2<sup>1</sup>/<sub>2</sub>"

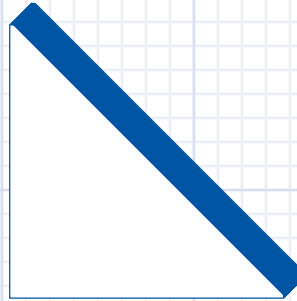

H20

**H14**  
 Pine  
 Cant Strip  
 1<sup>1</sup>/<sub>2</sub>" x 1<sup>1</sup>/<sub>2</sub>"

H14

**H15J**  
 Paint Grade  
 Sash Stool  
 1<sup>1</sup>/<sub>16</sub>" x 7<sup>1</sup>/<sub>4</sub>"

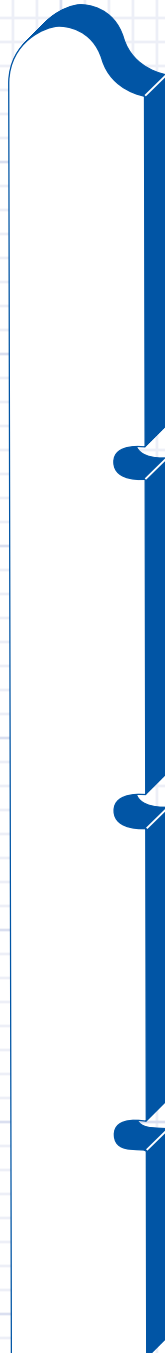

H15J

**H16J**  
 Paint Grade  
 Radius Stool  
 3<sup>1</sup>/<sub>4</sub>" x 5<sup>1</sup>/<sub>2</sub>"



H16J

**H18**  
 Redwood/Red Cedar  
 Sash Stool  
 1<sup>7</sup>/<sub>16</sub>" x 5<sup>1</sup>/<sub>8</sub>"

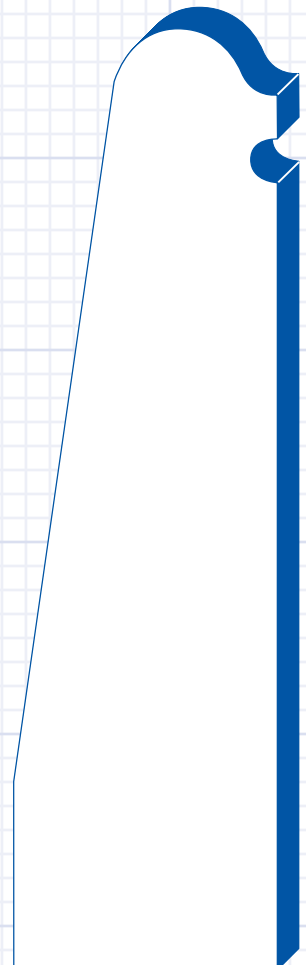

H18

**H20**  
 Pine/Fir  
 Chamfer Strip  
 1" x 1"

H6J

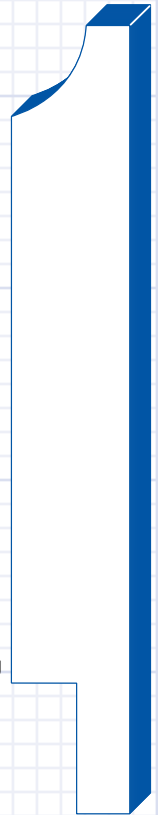

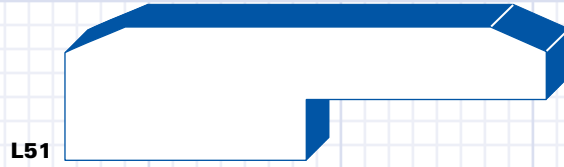

L51

**L51**  
Oak  
Threshold  
 $5/8" \times 2 1/2"$

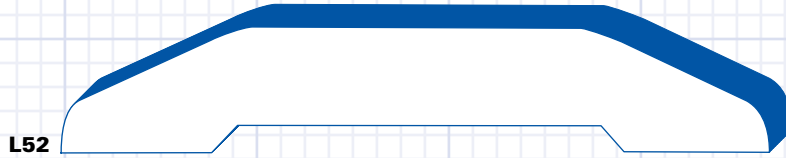

L52

**L52**  
Oak  
Threshold  
 $1 1/16" \times 3 5/8"$

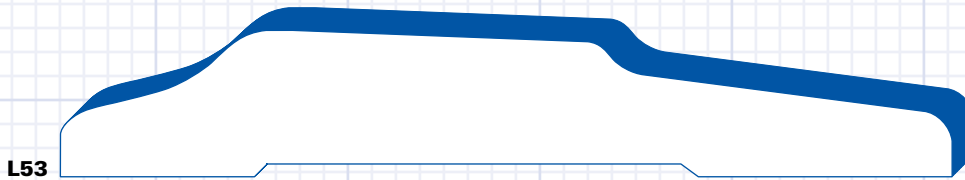

L53

**L53**  
Oak  
Threshold  
 $3/4" \times 4 5/8"$

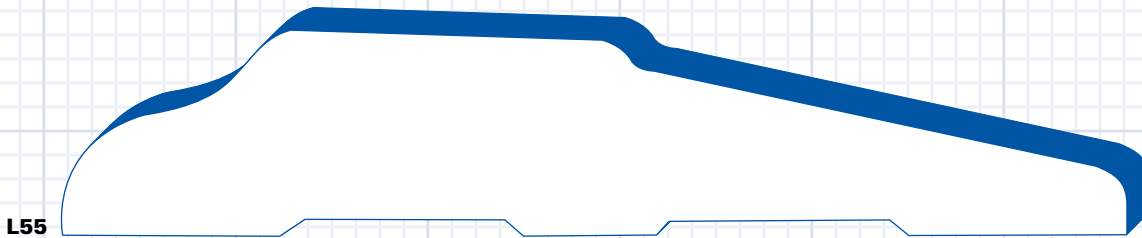

L55

**L55**  
Oak  
Threshold  
 $1" \times 5 5/8"$

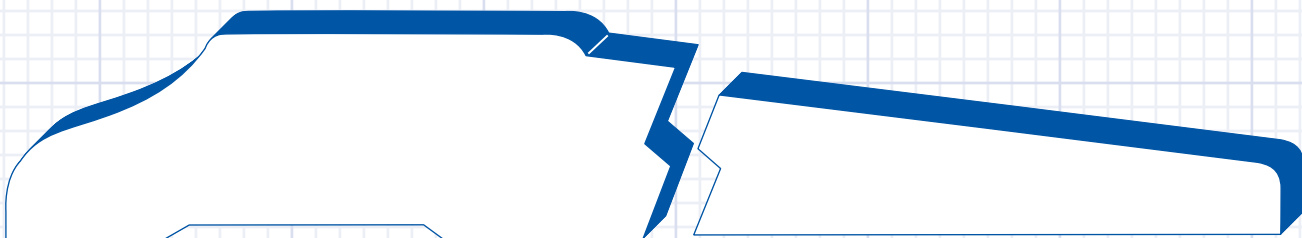

L122  
NET SIZE  $7 3/4"$

**L122**  
Oak  
Threshold  
 $1 1/16" \times 7 3/4"$



**L56**  
**Oak**  
Rabbeted Sill  
*1<sup>1</sup>/<sub>16</sub>" x 5<sup>1</sup>/<sub>4</sub>"*

**L57**  
**Oak**  
Rabbeted Sill  
*1<sup>1</sup>/<sub>16</sub>" x 7<sup>1</sup>/<sub>4</sub>"*

**L123**  
**Oak**  
Bar Rail  
*4<sup>13</sup>/<sub>16</sub>"*

**I1J**  
**Paint Grade**  
Interior Jamb Stock  
*1<sup>1</sup>/<sub>16</sub>" x 4<sup>9</sup>/<sub>16</sub>"*

**I2J**  
**Paint Grade**  
Interior Jamb Stock  
*1<sup>1</sup>/<sub>16</sub>" x 5<sup>1</sup>/<sub>4</sub>"*

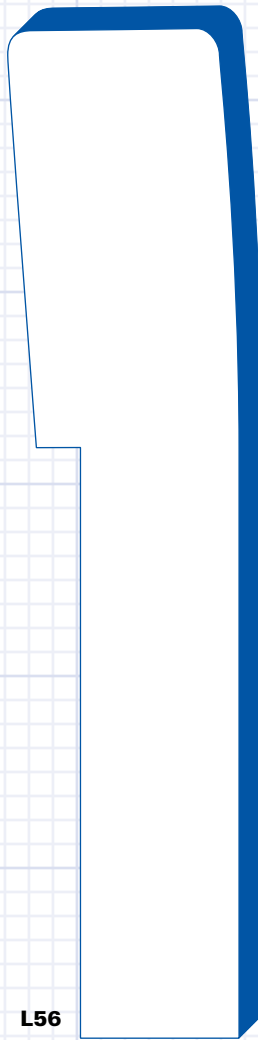

**L56**



**L57**

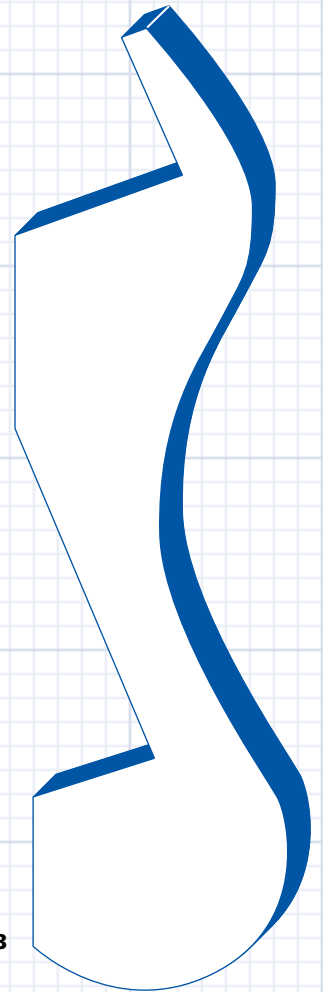

**L123**



**I1J**



**I2J**

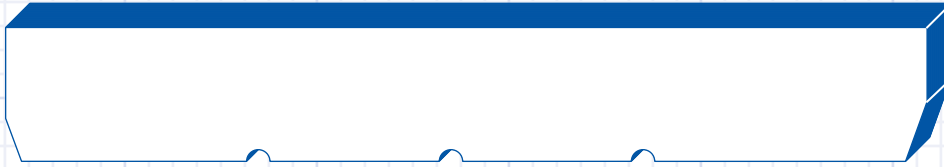

13J

**13J**  
**Paint Grade**  
Interior Jamb Stock  
 $1\frac{1}{16}'' \times 4\frac{13}{16}''$



14J

**14J**  
**Paint Grade**  
Exterior Jamb Stock  
 $1\frac{1}{4}'' \times 4\frac{5}{8}''$

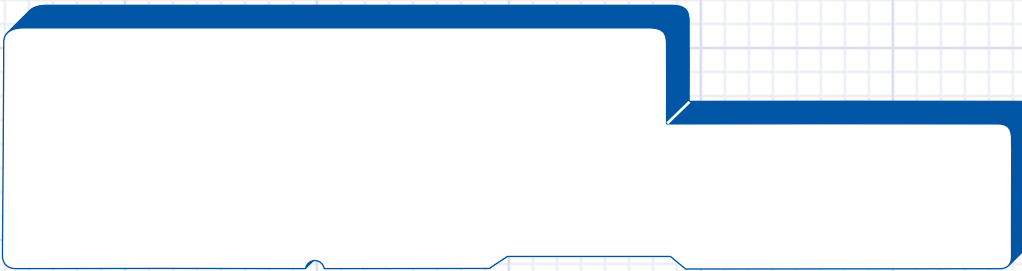

15J

**15J**  
**Paint Grade**  
Exterior Jamb Stock  
 $1\frac{1}{4}'' \times 5\frac{1}{4}''$

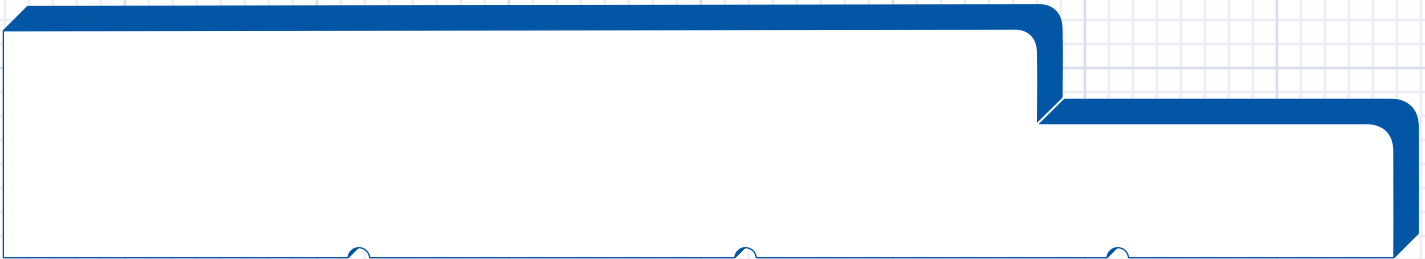

17J

**17J**  
**Paint Grade**  
 $1\frac{1}{4}'' \times 7\frac{1}{4}''$



18J

**18J**  
**Paint Grade**  
Jamb Stock  
 $1\frac{1}{16}'' \times 7\frac{1}{4}''$

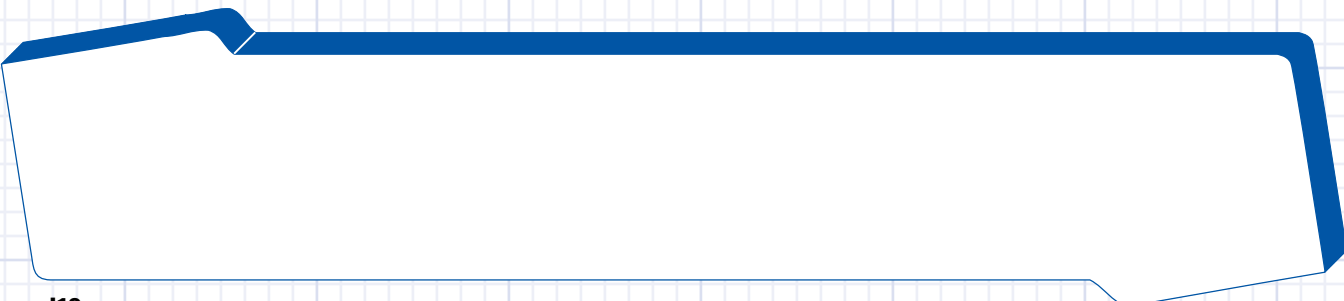

110

**110**  
**Redwood/Red Cedar**  
Sill  
 $2'' \times 8''$   
net size  $1\frac{1}{2}'' \times 7\frac{1}{4}''$

**J5J**

**House Whites**  
 Primed "Beaded"  
 1" x 4"  
 (9/16" x 3 1/8" face)



J5J

**J6C**

**Red Cedar**  
 Clear Heart VG "Beaded" TG  
 1" x 4"  
 (5/8" x 3 1/8" face)



J6C  
 J6J  
 J6K

**J6J**

**House Whites**  
 Clear "Beaded" TG  
 1" x 4"  
 (9/16" x 3 1/8" face)

**J6K**

**Knotty Pine**  
 "Beaded" TG  
 1" x 4"  
 (11/16" x 3 1/8" face)

**J7**

**Redwood**  
 Cap  
 1 1/4" x 1 1/2"

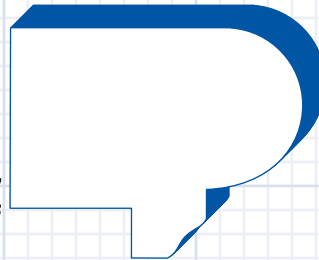

J7  
 J7F

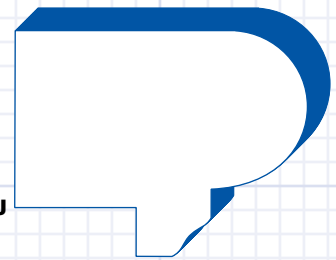

J7J

**J7F**

**Fir**  
 Cap  
 1 1/4" x 1 1/2"

**J7J**

**Paint Grade**  
 Cap  
 1 1/4" x 1 5/8"

**J7P**

**Paint Grade**  
 Cap  
 1 3/16" x 1 3/16"

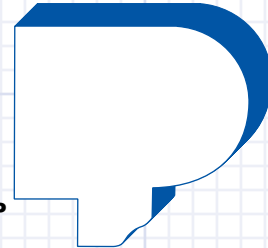

J7P

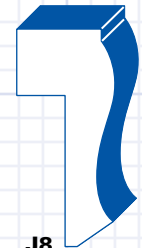

J8

**J8**

**Pine**  
 Panel Cap  
 1/2" x 1 1/8"

**J9**

**Paint Grade**  
 Cap  
 1 3/16" x 2"



J9



J19J



J23J



J29J

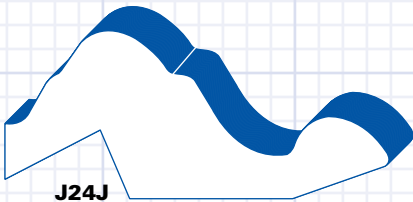

J24J

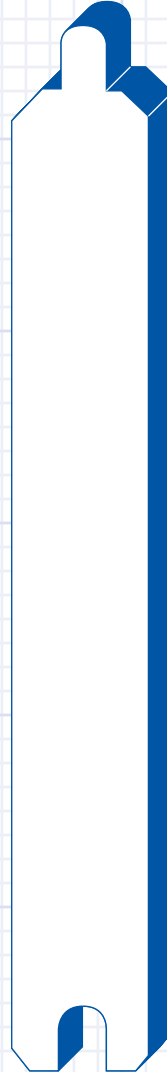

J37J

**J19J**  
**Paint Grade**  
 Primed "V-Wall" TG  
 $1\frac{1}{2}'' \times 4''$   
 ( $7\frac{1}{16}'' \times 3''$  face)

**J23J**  
**Paint Grade Primed**  
 "Bead-Wall" TG  
 $7\frac{1}{16}'' \times 4''$   
 ( $1\frac{3}{32}'' \times 3''$  face)

**J24J**  
**Paint Grade**  
 "Varia" Wainscot Cap  
 2"

**J29J**  
**House Whites**  
 Primed "Beaded"  
 $1'' \times 6''$   
 ( $3\frac{1}{4}'' \times 5\frac{1}{8}''$  face)

**J37J**  
**House Whites**  
 Primed "V"  
 $1'' \times 6''$   
 ( $3\frac{1}{4}'' \times 5\frac{1}{8}''$  face)

**J39J**

**Windsor 1 Primed**  
 Hawaiian "V" TG  
 1" x 8"  
 (3/4" x 7 1/8" face)

**J58**

**Douglas Fir**  
**Select Struct**  
 "V" Face/"SE" Back  
 2" x 6"  
 (1 7/16" x 5" face)

**J111**

**House White**  
 Reversible Int Lap  
 1" x 6"

**J47**

**Arauco 2" OC**  
 "Beaded" Plywood  
 3/8" x 4' x 8'  
 4' x 8' Panel

**J106**

**FJ Pine**  
 Primed Nickel Gap  
 9/16" x 6"

**J196J**

**FJ Poplar**  
 Primed "V" TG  
 7/16" x 6"

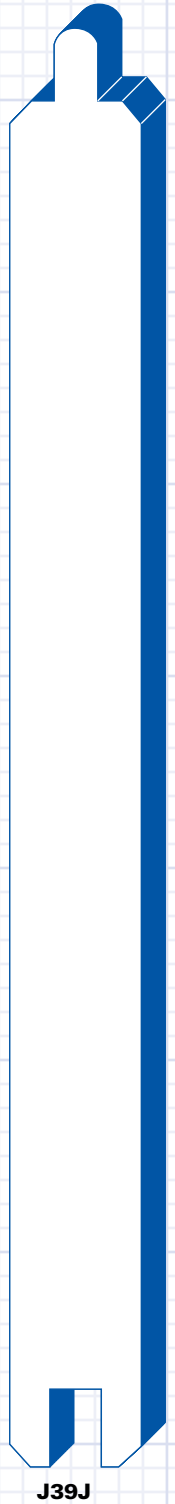
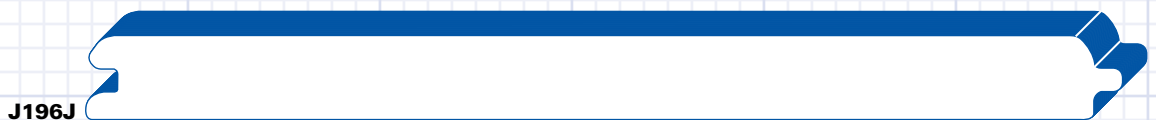
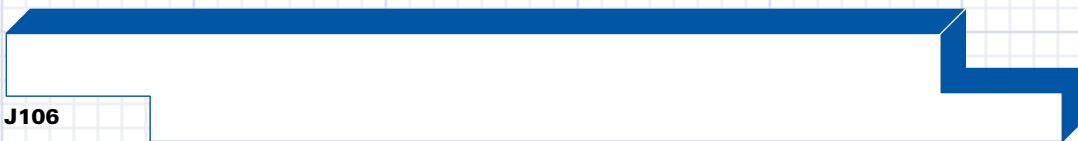
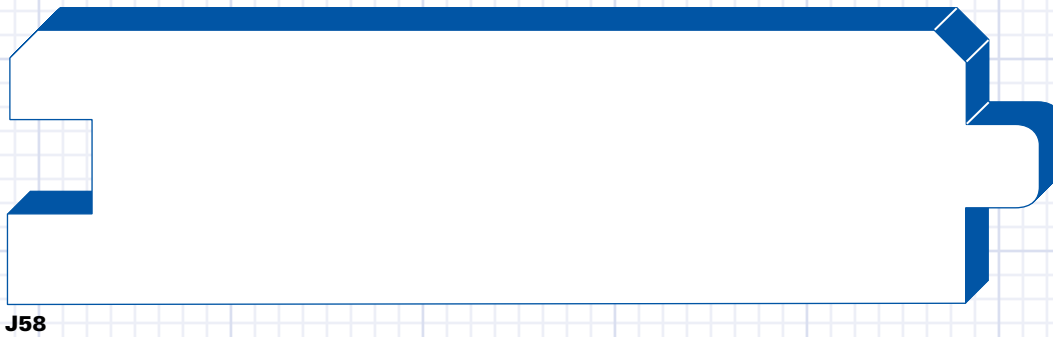
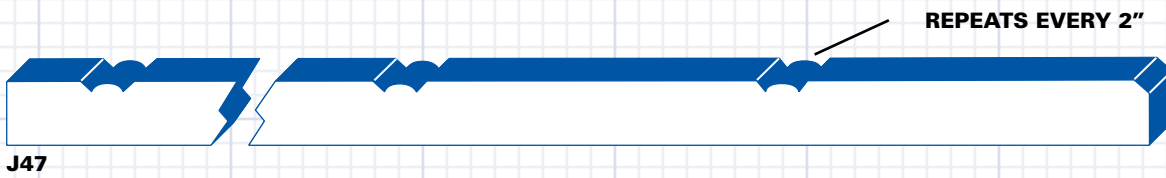

**J3**

**Douglas Fir**  
 C/Btr VG Clear TG  
 1" x 4"  
 (3/4" x 3 1/4" face)

**J3C**

**Alaskan Yellow**  
 Cedar Solid TG  
 1" x 4"  
 (3/4" x 3 1/4" face)

**K4-6J**

**House Reds FJ-EG**  
 Primed "V"  
 1" x 6"  
 (1 1/16" x 5" face)

**K4-8J**

**House Reds FJ-EG**  
 Primed "V"  
 1" x 8"  
 (1 1/16" x 7" face)

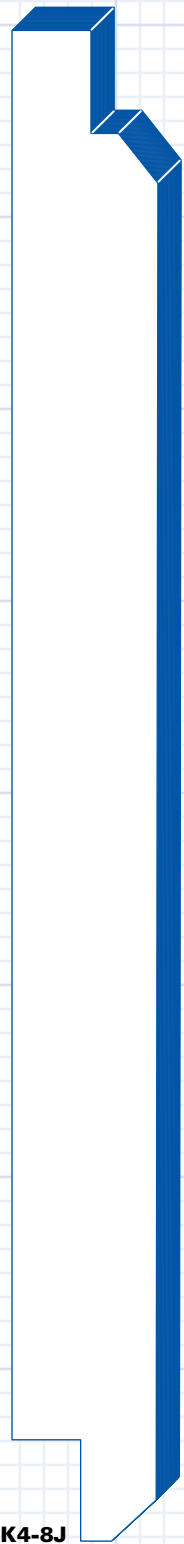

K4-8J

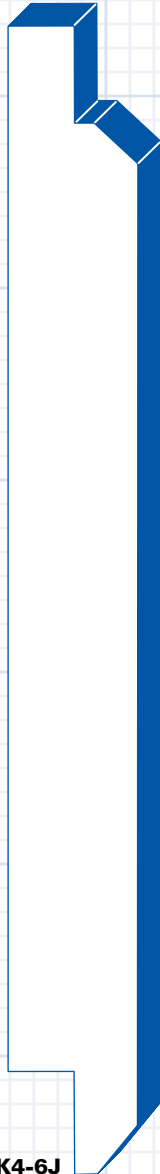

K4-6J



J3  
 J3C

**K1-8J\***

**House Reds FJ-EG**

Primed "Cove"

1" x 8"

(1<sup>1</sup>/<sub>16</sub>" x 7" face)

**K1-10C\***

**House Reds A-VG**

"Cove Rustic"

1" x 10"

(3<sup>1</sup>/<sub>4</sub>" x 9" face)

**K1-10J\***

**House Reds FJ-EG**

Primed "Cove"

1" x 10"

(1<sup>1</sup>/<sub>16</sub>" x 9" face)

**K4-10J\***

**House Reds FJ-EG**

Primed "V"

1" x 10"

(1<sup>1</sup>/<sub>16</sub>" x 9" face)

**K5-8J\***

**House Reds FJ-EG**

Primed "Channel Rustic"

1" x 8"

(1<sup>1</sup>/<sub>16</sub>" x 7" face)

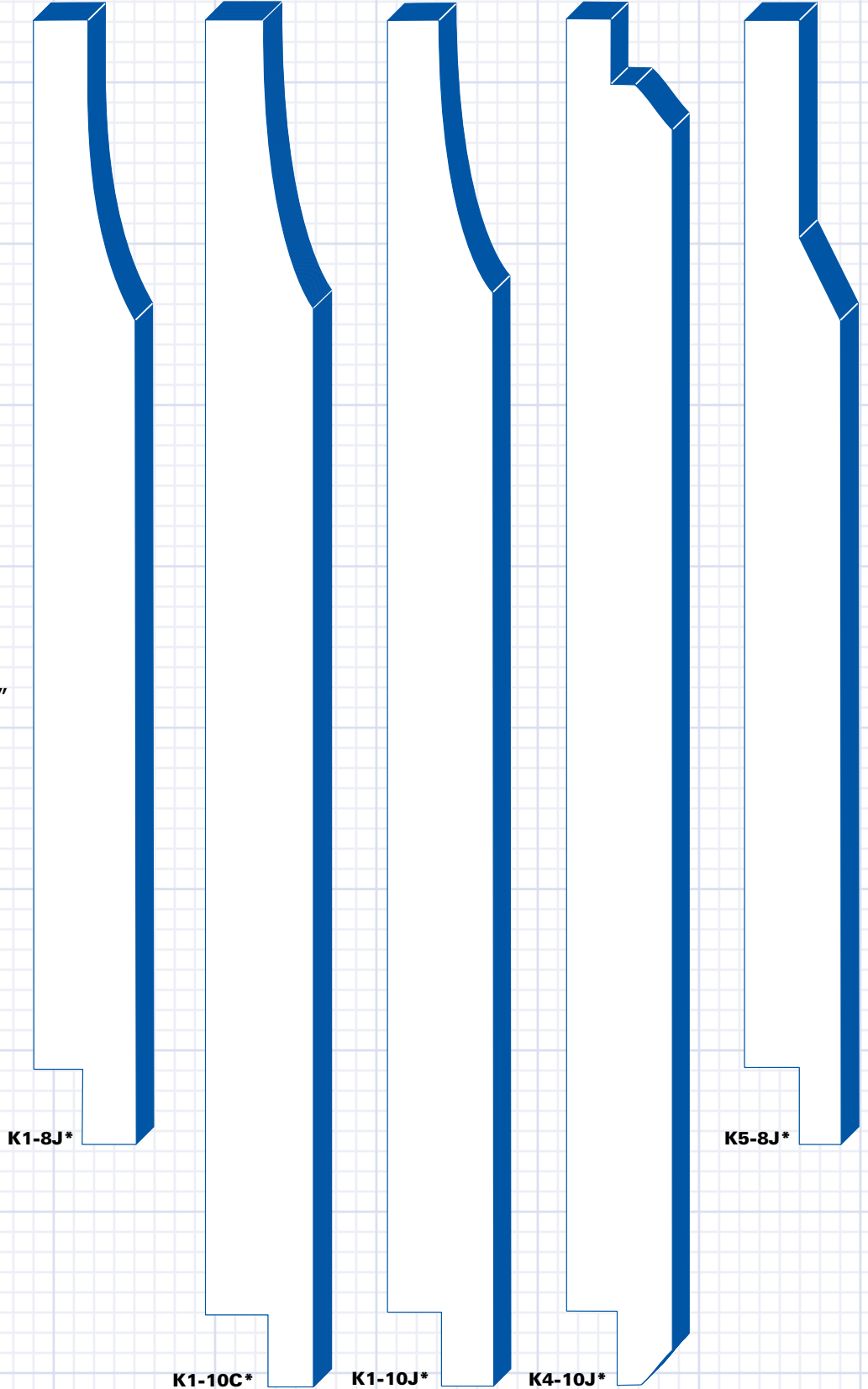

*\*Not shown to scale*

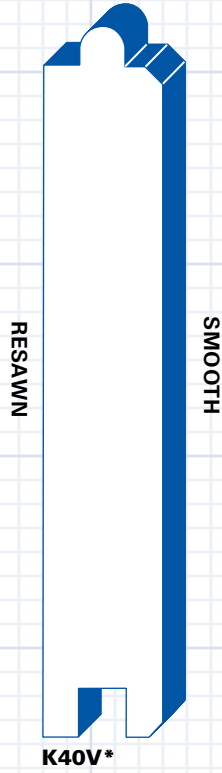
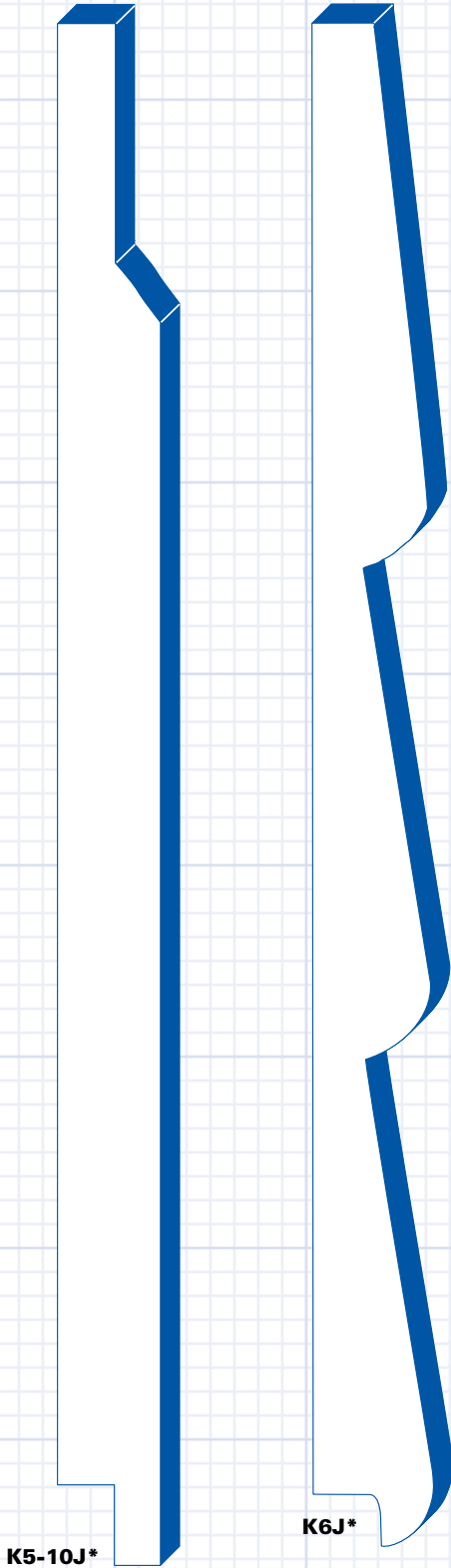

**K5-10J\***  
**House Reds FJ-EG**  
 Primed "Channel"  
 1" x 10"  
 (1 1/16" x 9" face)

**K6J\***  
**House Reds FJ-EG**  
 Primed "Triple Lap"  
 1" x 10"  
 (1 1/16" x 9" face)

**K40V\***  
**Western Red Cedar**  
 Clear Heart  
 (10% B) VG R/S TG  
 1 1/16" x 4"  
 (1 1/16" x 3 1/2" face)

**K42V\***  
**Western Red Cedar**  
 Clear Heart  
 (10% B) VG R/S TG  
 1" x 6"  
 (3/4" x 5 1/4" face)

**K44\***  
**Red Cedar A VG**  
 Square Edge T&G  
 1" x 4"  
 (3/4" x 3 1/4" exposed face)

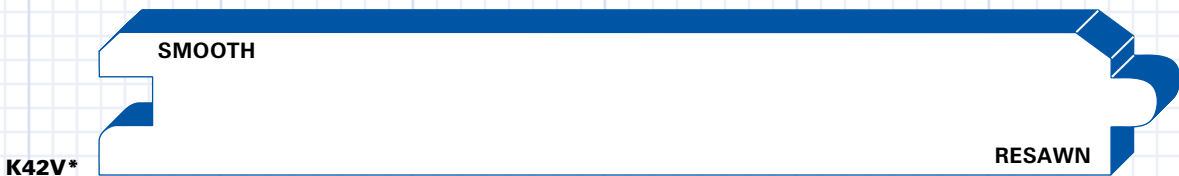

*\*Not shown to scale*



**K45R**

**Redwood Fireblocker™**  
 Primed FJ/EG VG Belgium Lap  
 1" x 4"  
 (1<sup>1</sup>/<sub>16</sub>" x 3<sup>1</sup>/<sub>8</sub>" exposed face)

**K46V**

**CLR VG Smooth SQ CM TG**  
 Red Cedar  
 1" x 6"  
 (3<sup>1</sup>/<sub>4</sub>" x 5<sup>9</sup>/<sub>32</sub>" face)

**K49**

**Red Cedar Tight Knot**  
 Bevel Rainscreen  
 1" x 6"  
 (3<sup>1</sup>/<sub>4</sub>" x 5<sup>9</sup>/<sub>32</sub>" face)

**K59**

**Red Cedar Tight Knot**  
 Eased Edge T&G  
 1" x 6"  
 (3<sup>1</sup>/<sub>4</sub>" x 5" exposed face)



**K45R**



**K46V**

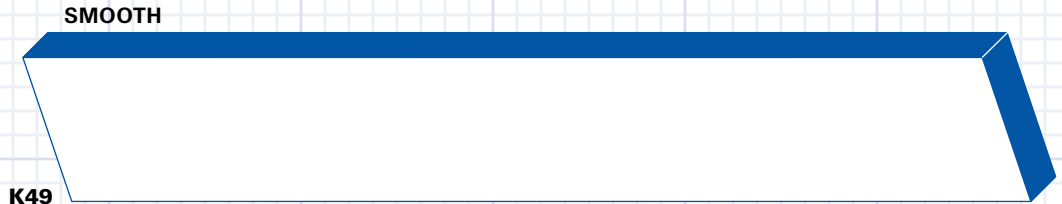

**K49**

**RESAWN**

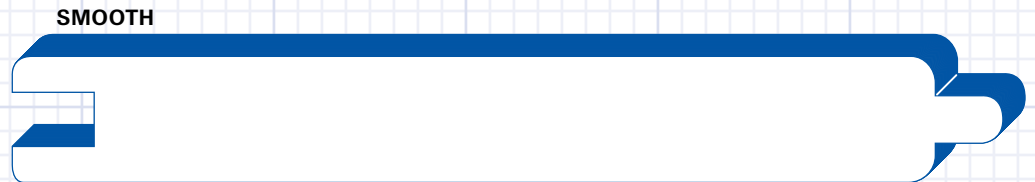

**K59**

**RESAWN**

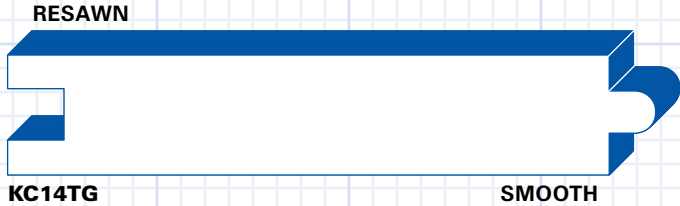

**KC14TG**  
 Red Cedar  
 STK SIS/RS TG  
 1" x 4"

**K575**  
 Thermally Modified  
 Hemlock VG  
 "Fineline" T&G  
 1" x 6"  
 (3/4" x 5 1/4" exposed face)

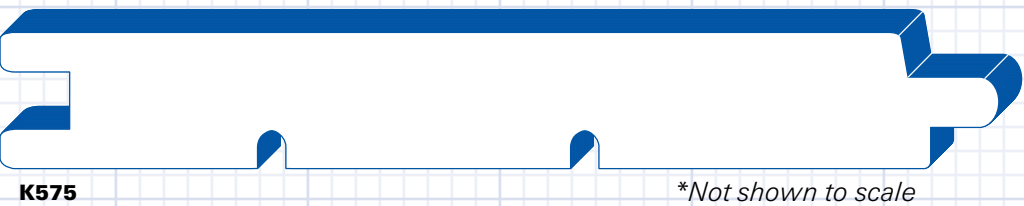

**K66C\***  
 Red Cedar A VG  
 Rainscreen Lap  
 1" x 6"  
 (3/4" x 4 15/16" exposed face)  
 Install with clips

**K75SE\***  
 Red Cedar A VG  
 "Fineline" T&G  
 1" x 6"  
 (3/4" x 5 1/4" exposed face)

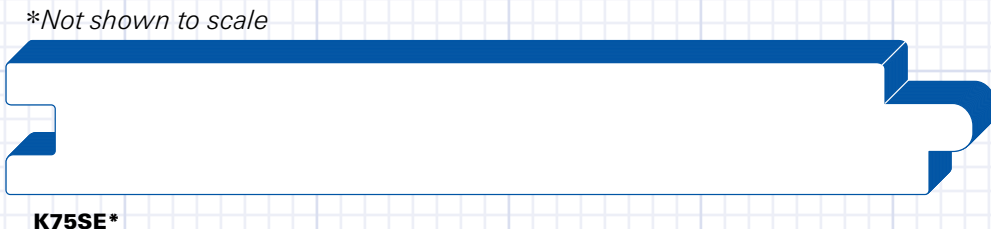
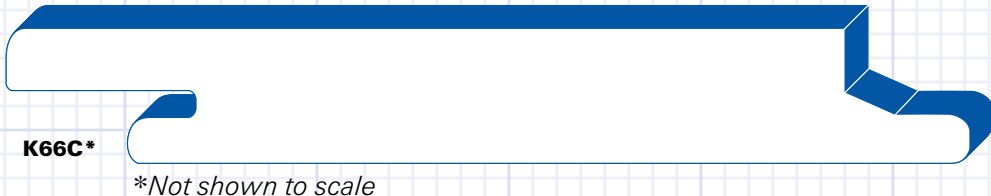

*\*Not shown to scale*

**RFB14T**

**Redwood Fireblocker™**

Primed FJ/EG V T&G  
 1" x 4"  
 (1<sup>1</sup>/<sub>16</sub>" x 3" exposed face)

**RFB14T**



**RFB16B**

**Redwood Fireblocker™**

Primed FJ/EG V Bevel Siding  
 3/4" x 6"  
 (1<sup>1</sup>/<sub>16</sub>" x 5" exposed face)

**RFB16T**

**Redwood Fireblocker™**

Primed FJ/EG V Bevel Siding  
 1" x 6"  
 (1<sup>1</sup>/<sub>16</sub>" x 5" exposed face)

**RFB18B**

**Redwood Fireblocker™**

Primed FJ/EG V Bevel Siding  
 3/4" x 8"  
 (1<sup>1</sup>/<sub>16</sub>" x 7" exposed face)

**RFB373**

**Redwood Fireblocker™**

Primed FJ/EG V Bevel Siding  
 3/4" x 10"  
 (1<sup>1</sup>/<sub>16</sub>" x 9" exposed face)

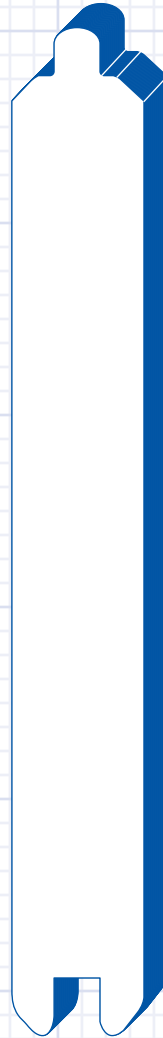

**RFB16T**

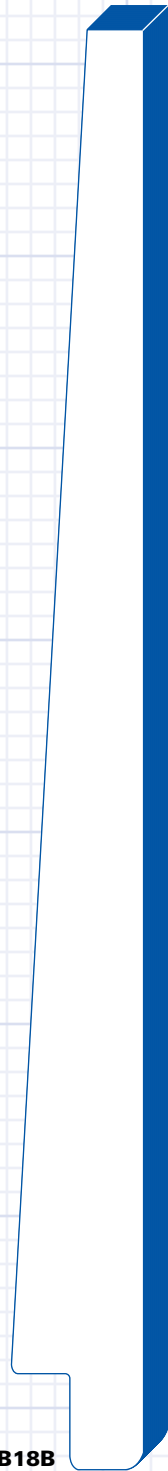

**RFB18B**

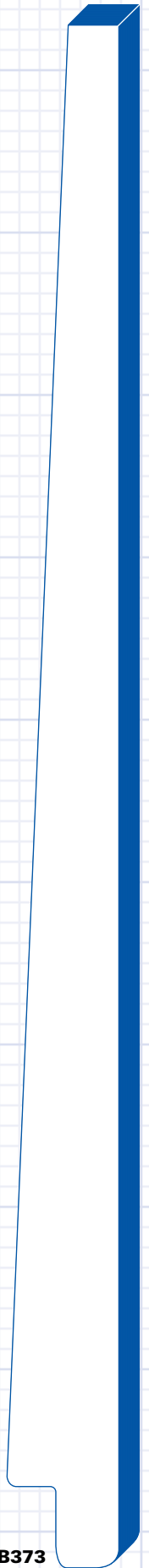

**RFB373**

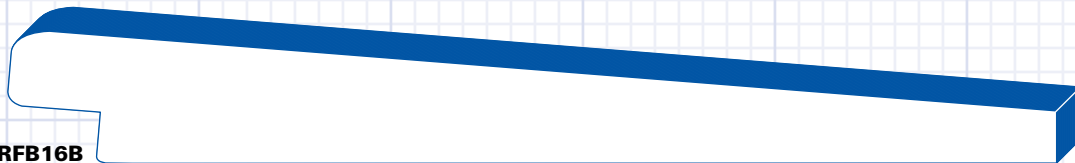

**RFB16B**

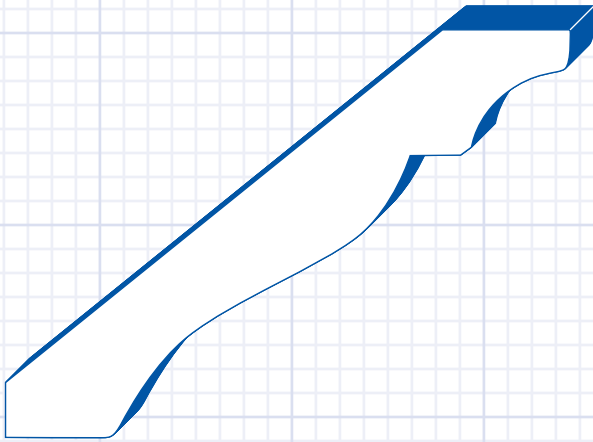

**EX286**

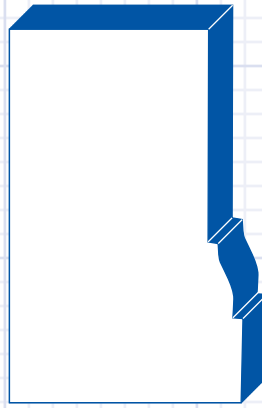

**EX381**

**EX286**  
Treated Pine  
Crown  
3<sup>5</sup>/<sub>8</sub>"

**EX381**  
Treated Pine  
Brick  
2"

**EX381K**  
Treated Pine  
Brick/Key  
2"

**EX604**  
Treated Pine  
Corner MLG  
1<sup>1</sup>/<sub>2</sub>"

**EX606**  
Treated Pine  
Cove  
3<sup>1</sup>/<sub>4</sub>"

**EX607**  
Treated Pine  
Pediment  
1<sup>1</sup>/<sub>2</sub>"

**EX1400**  
Treated Pine  
Architrave  
4<sup>1</sup>/<sub>4</sub>"

**EX614**  
Treated Pine  
Quarter Round  
3<sup>1</sup>/<sub>4</sub>"

**EX616**  
Treated Pine  
Shingle MLG  
1<sup>5</sup>/<sub>8</sub>"

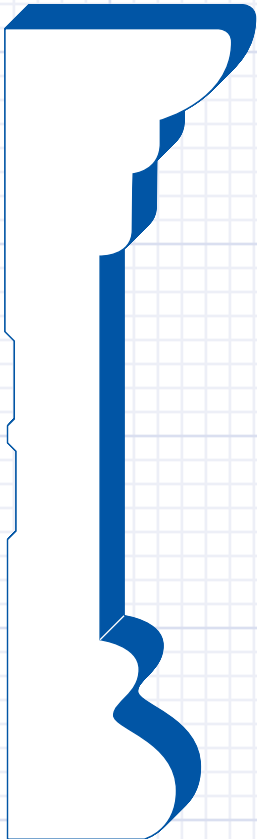

**EX1400**

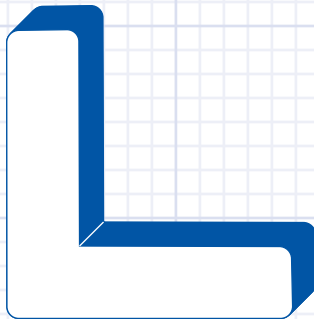

**EX604**



**EX381K**

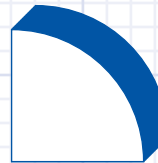

**EX614**



**EX606**

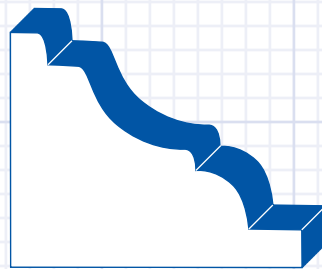

**EX607**

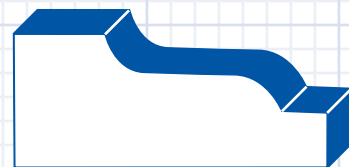

**EX616**

*\*Not shown to scale*

**EX618**  
Treated Pine  
Stucco MLG  
1 1/2"

**EX619**  
Treated Pine  
Brick MLG  
1 3/8"

**EX627**  
Treated Pine  
Stucco MLG  
1 15/16"

**EX629**  
Treated Pine  
Stucco MLG  
2 1/2"

**EX630**  
Treated Pine  
Water Table  
1 7/8"

**EX634**  
Treated Pine  
Water Table  
3 1/4"

**EX638**  
Treated Pine  
Cutter MLG  
3 5/16"

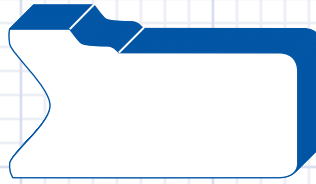

EX618

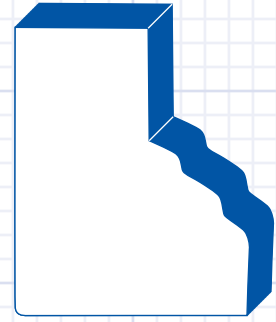

EX619

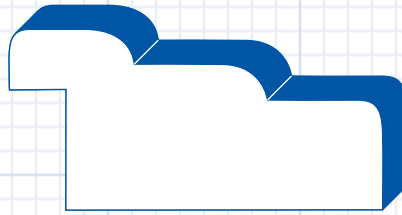

EX627

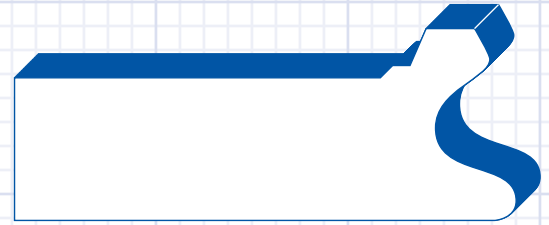

EX629

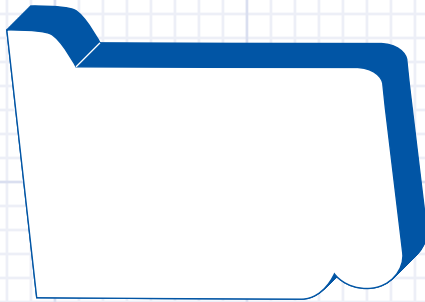

EX630

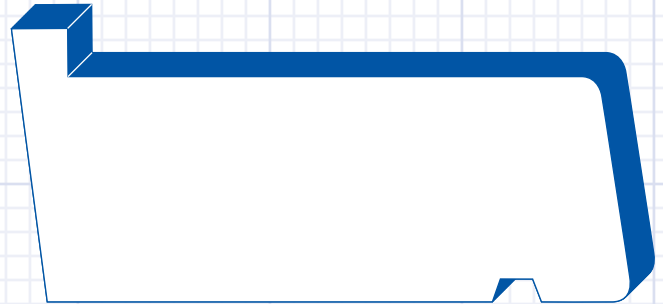

EX634

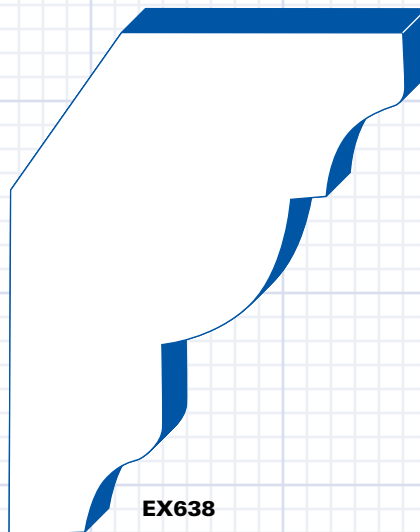

EX638

*\*Not shown to scale*

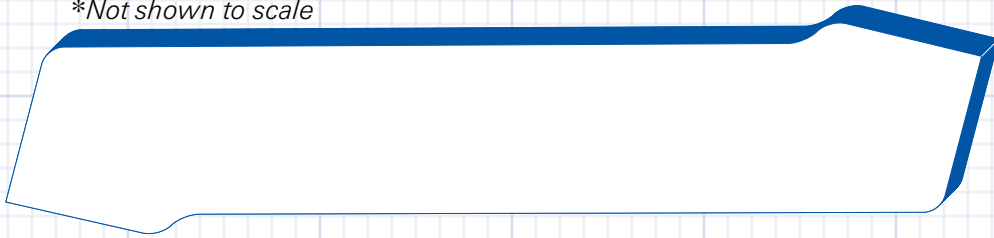

**EX640\***

**EX640\***  
Treated Pine  
Rev Sill  
7 1/4"

**KA1-8\***  
Bodyguard  
Treated Cove Rustic  
1" x 8"  
(3/4" x 7" face)

**KA1-10\***  
Bodyguard  
Treated Cove Rustic  
1" x 10"  
(3/4" x 9" face)

**KA5-8\***  
Bodyguard  
Treated Channel Rustic  
1" x 8"  
(3/4" x 7" face)

**KA5-10\***  
Bodyguard  
Treated Channel Rustic  
1" x 10"  
(3/4" x 9" face)

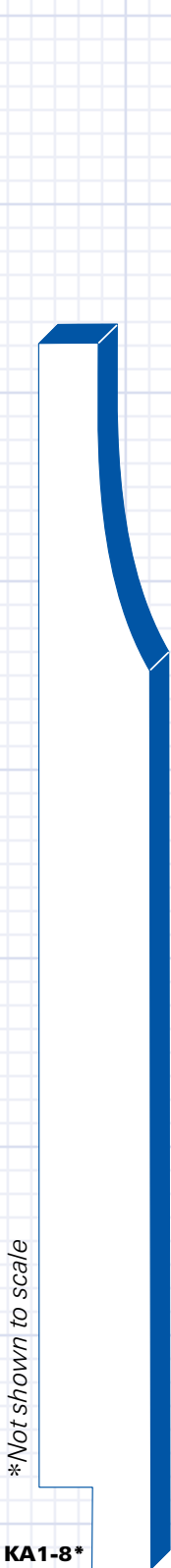

*\*Not shown to scale*

**KA1-8\***



*\*Not shown to scale*

**KA1-10\***



*\*Not shown to scale*

**KA5-8\***

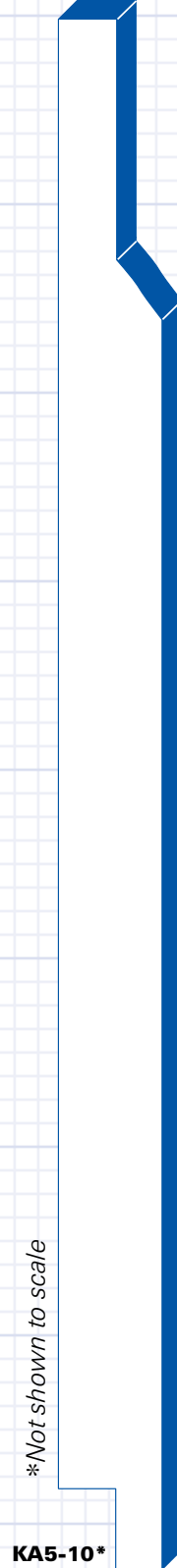

*\*Not shown to scale*

**KA5-10\***

*\*Not shown to scale*

**KA5J**

**Bodyguard**  
"Beaded" TG  
5/8" x 4"  
(9/16" x 3 1/8" face)

**KA6**

**Bodyguard**  
Treated 3-Cap Rustic  
1" x 10"  
(3/4" x 9" face)

**KA11**

**Bodyguard**  
Treated 2-Cap Rustic  
1" x 6"  
(3/4" x 5 1/8" face)

**KA29**

**Bodyguard**  
"Beaded" TG  
1" x 6"  
(3/4" x 5 1/8" face)

**KA75**

**Bodyguard**  
"Nickel Gap" Shiplap  
1" x 6"  
(3/4" x 5 1/4" exposed face)

KA5J



KA6

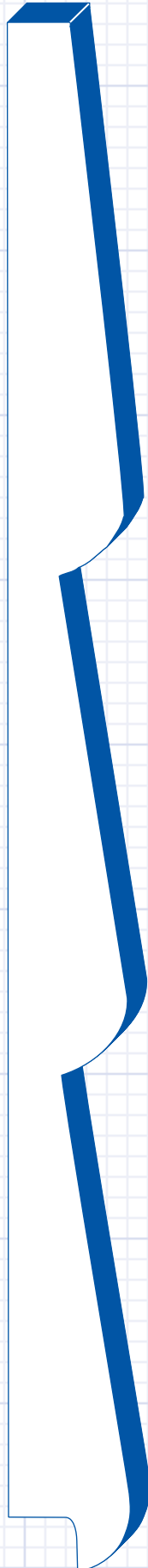

KA11

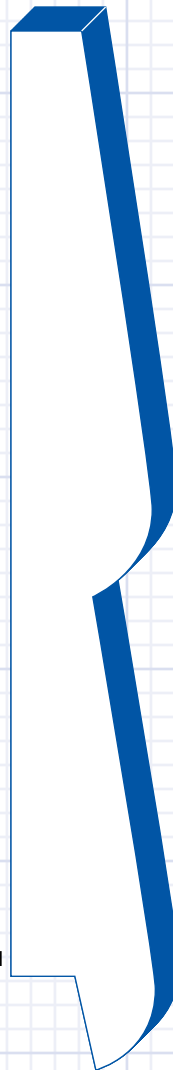

KA29



KA75

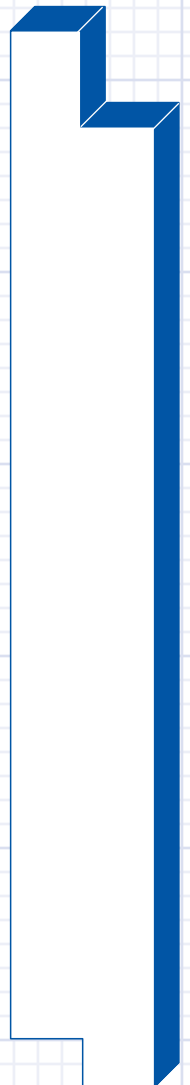

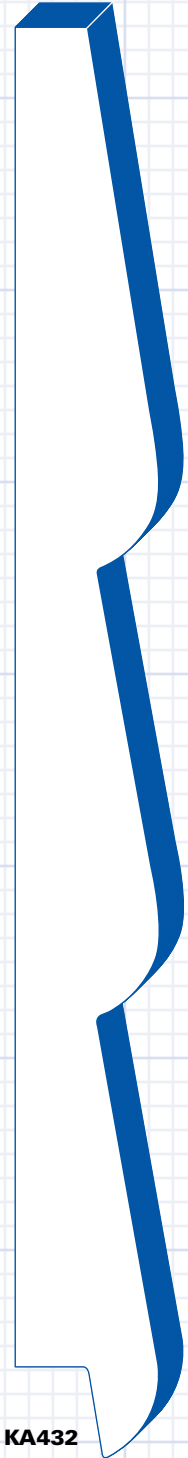

**KA432**



**KA4-6**

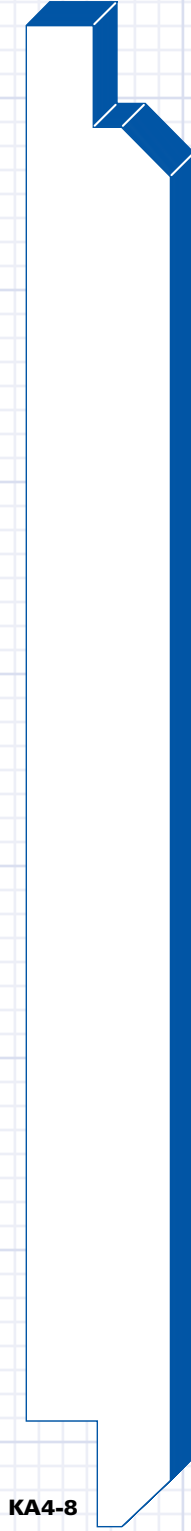

**KA4-8**



**KA4-10\***

*\*Not shown to scale*

**KA432**  
**Bodyguard**  
Triple Lap  
1" x 8"  
(<sup>3</sup>/<sub>4</sub>" x 7" exposed face)

**KA4-6**  
**Bodyguard**  
Treated V Rustic  
1" x 6"  
(<sup>3</sup>/<sub>4</sub>" x 5 <sup>1</sup>/<sub>8</sub>" face)

**KA4-8**  
**Bodyguard**  
Treated V Rustic  
1" x 8"  
(<sup>3</sup>/<sub>4</sub>" x 7" face)

**KA4-10\***  
**Bodyguard**  
Treated V Rustic  
1" x 10"  
(<sup>3</sup>/<sub>4</sub>" x 9" face)

*\*Not shown to scale*



**FF12**  
**Hemlock**  
 Fillet  
 1/4" x 1 1/4"



**FF15**  
**Hemlock**  
 Fillet  
 1/4" x 1 5/8"

**FR2**  
**Hemlock**  
 Hampton Rail  
 2 3/8" (1 5/8" plow)

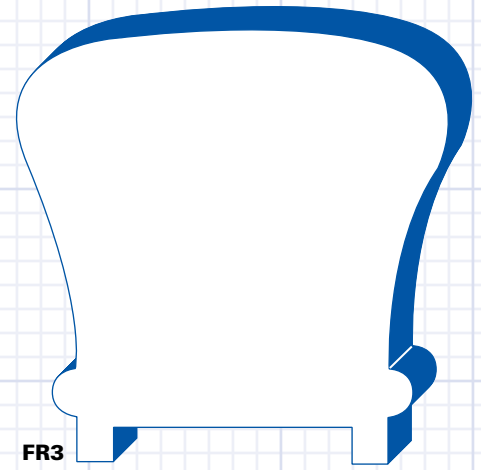
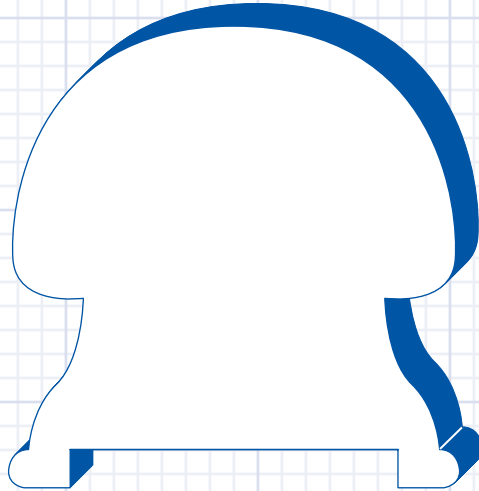

**FR3**  
**Hemlock**  
 Newport Rail  
 2 1/4" (1 1/4" plow)

**FR3A**  
**Hemlock**  
 Newport Rail  
 2 1/4"

**FR4A\***  
**Redwood/Red Cedar**  
 Rail Cap  
 4"

**FR4B\***  
**Redwood/Red Cedar**  
 Rail Side  
 1" x 3"  
 (For use with 3" x 3"  
 Baluster)  
 1" x 4"  
 (For use with 4" x 4"  
 Baluster)

**FR5R**  
**Redwood/Red Cedar**  
 Mushroom Plowed  
 Rail  
 1 1/2" x 2 1/4" (3/4" plow)

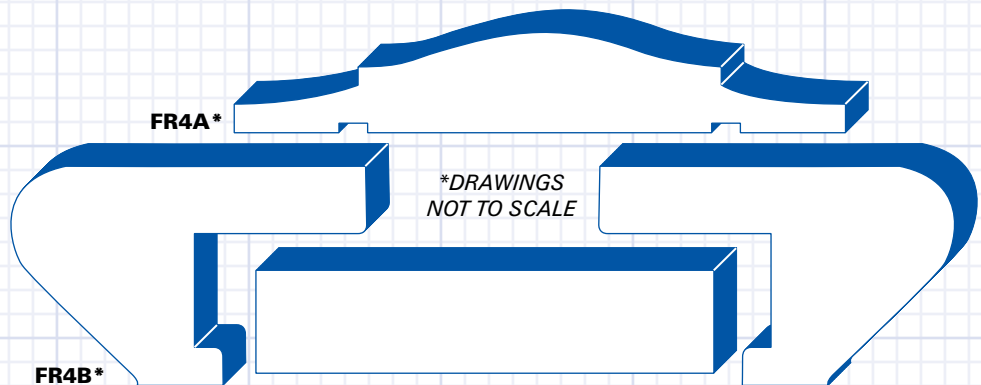
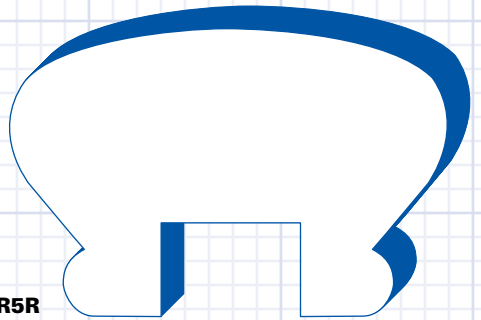
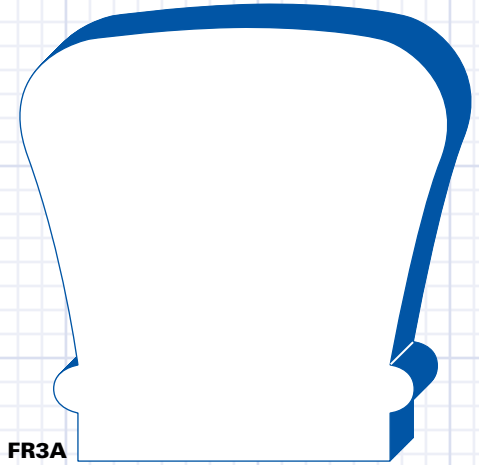

\*Not shown to scale

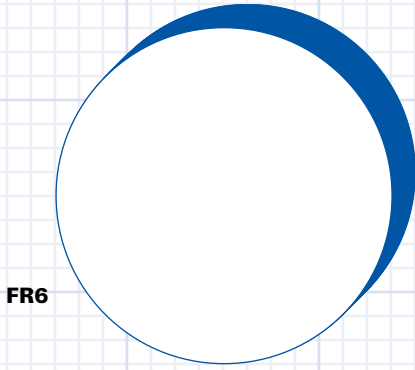

FR6

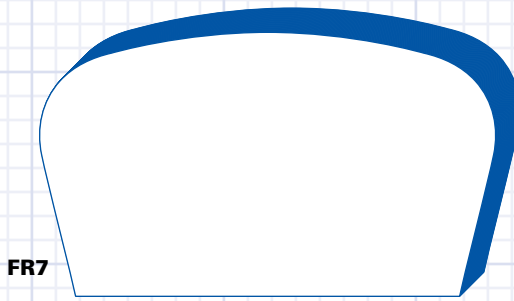

FR7

**FR6**

Fir  
Round Rail  
1 3/4"

**FR7**  
Wall Rail

2 3/8"

**FR8**

Fir  
Round Rail  
1 1/2"

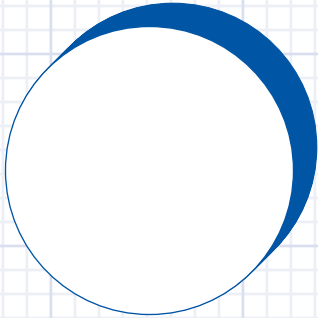

FR8

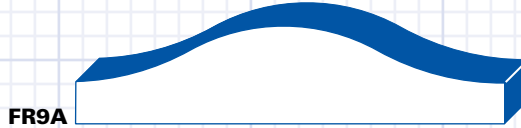

FR9A

**FR9A**

Redwood/Red Cedar  
Handrail  
1 1/2" x 2 1/4"

**FR9B**

Redwood/Red Cedar  
Handrail  
1 1/2" x 3 1/2"



FR9B

**FR9F**

Redwood/Red Cedar  
Foot Rail  
1 1/2" x 3 1/2"

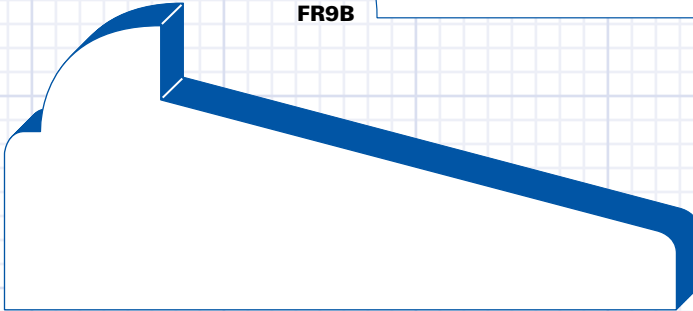

FR9F

**FR10A**

Redwood/Red Cedar  
Handrail  
3/4" x 3 5/8"



FR10A

**FR10B**

Redwood  
Handrail  
1 1/2" x 5"



FR10B

**FR19\***

**Douglas Fir**  
Mushroom Flat Rail  
1 7/16" x 1 15/16"



**FR19\***  
**FR19C\***

**FR19C\***

**Redwood/Red Cedar**  
Mushroom Flat Rail  
1 7/16" x 1 15/16"



**FS24\***

**FS12\***

**Hemlock**  
Shoe  
1 3/16" x 2 1/2" (1 1/4" plow)



**FS12\***

**FS24\***

**Hemlock**  
Shoe  
1 1/4" x 2 1/2" (1 5/8" plow)

**FS31\***

**Redwood**  
Shoe Rail  
7/8" x 3 1/8" (1 3/8" plow)

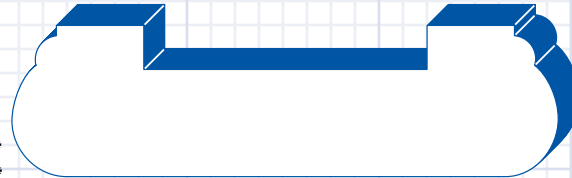

**FS31\***  
**FS31P\***

**FS31P\***

**Paint Grade**  
Shoe Rail  
7/8" x 3 1/8" (1 5/8" plow)

**MR14\***

**Redwood**  
Rail  
2 3/4" (1 3/8" plow)

**MR14P\***

**Poplar**  
Rail  
2 3/4" (1 5/8" plow)

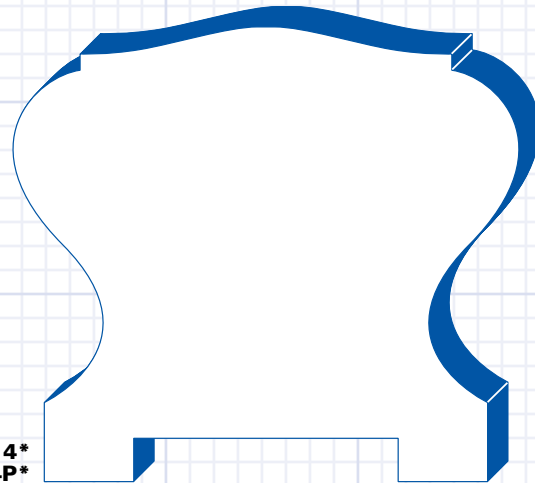

**MR14\***  
**MR14P\***

**MR16\***

**Mahogany**  
Handrail  
1 3/4"

**MR17\***

**Redwood/Red Cedar**  
Handrail  
2"

**MR18\***

**Maple**  
Round Rail  
2"

**MR19\***

**Cherry**  
Round Rail  
2"

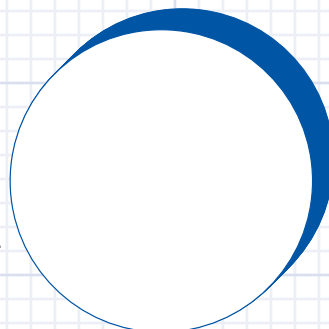

**MR16\***

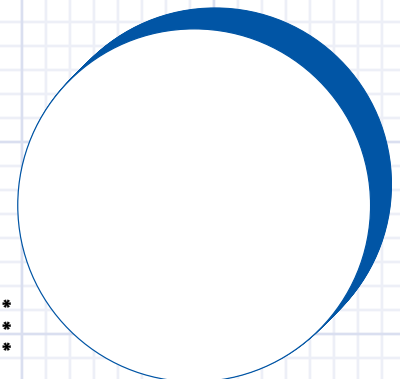

**MR17\***  
**MR18\***  
**MR19\***

*\*Not shown to scale*

MR21  
MR22  
MR30  
MR34

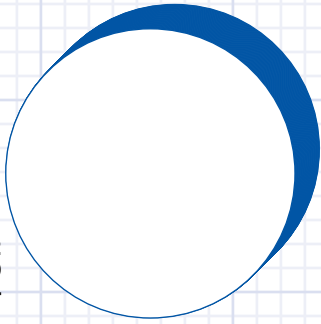

MR21F

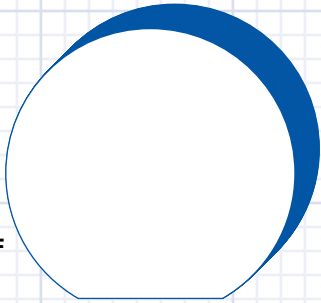

MR32

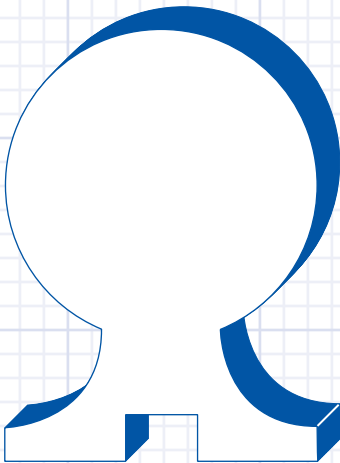

MR20

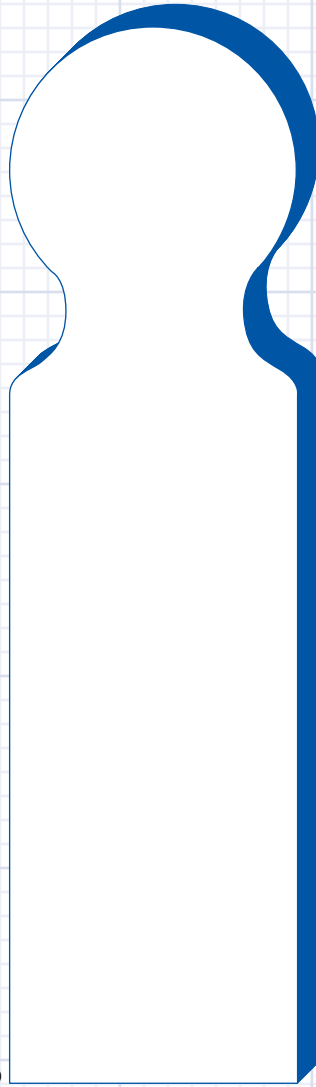

OF12



OF13



OF15



OF16



**MR20**

**Redwood**

Handrail  
 $5\frac{1}{2}'' \times 1\frac{1}{2}''$

**MR21**

**Redwood/Red Cedar**

Round Rail  
 $1\frac{1}{2}''$

**MR21F**

**Redwood/Red Cedar**

Round Rail Flat Bottom  
 $1\frac{1}{2}''$

**MR22**

**Maple**

Handrail  
 $1\frac{1}{2}''$

**MR30**

**Mahogany**

Round Rail  
 $1\frac{1}{2}''$

**MR32**

**Redwood/Red Cedar**

Rail  
 $2\frac{1}{4}'' \times 1\frac{5}{8}''$

**MR34**

**Maple**

Round Rail  
 $1\frac{1}{2}''$

**OF12**

**Oak**

Fillet  
 $\frac{5}{16}'' \times 1\frac{1}{4}''$

**OF13**

**Oak**

Fillet  
 $\frac{3}{8}'' \times 1\frac{1}{4}''$

**OF15**

**Oak**

Fillet  
 $\frac{5}{16}'' \times 1\frac{5}{8}''$

**OF16**

**Oak**

Fillet  
 $\frac{5}{16}'' \times 1\frac{3}{4}''$

**OR1**  
Oak  
Handrail  
1 3/4"

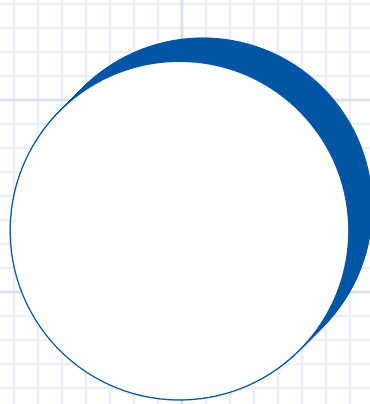

OR1

**OR2**  
Oak  
Round Rail  
2"

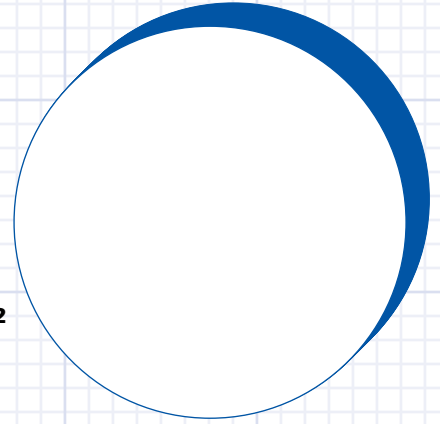

OR2

**OR3**  
Oak  
Wall Rail  
2 3/8"

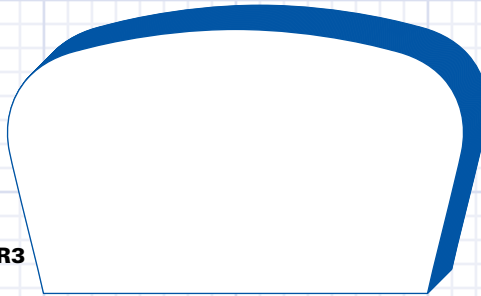

OR3

**OR4**  
Oak  
Round Rail  
1 1/2"

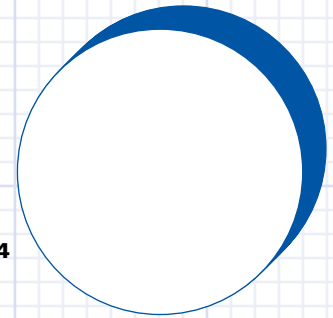

OR4

**OR6**  
Oak  
Newport Rail  
2 1/4"

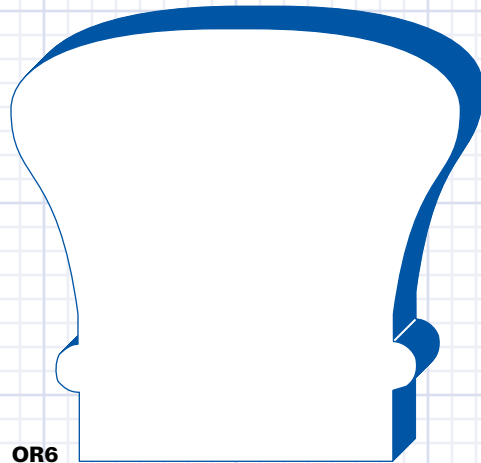

OR6

**OR7**  
Oak  
Newport Plowed Rail  
2 1/4" (1 1/4" plow)

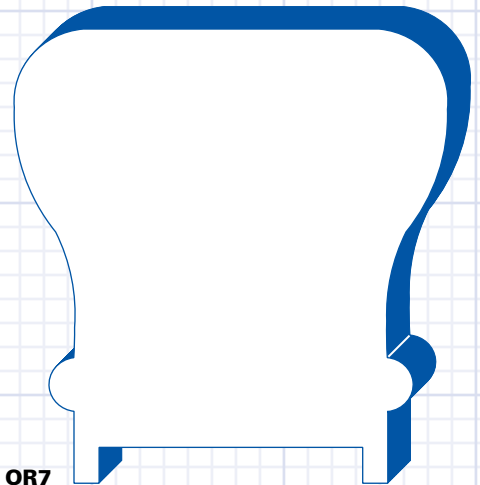

OR7

**OR8**  
Oak  
Colonial Rail  
2 3/4"

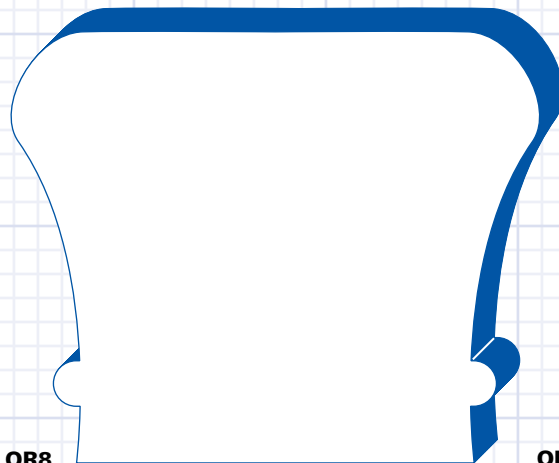

OR8

**OR9**  
Oak  
Jr. Hampton Rail  
2 1/2" (1 1/4" plow)

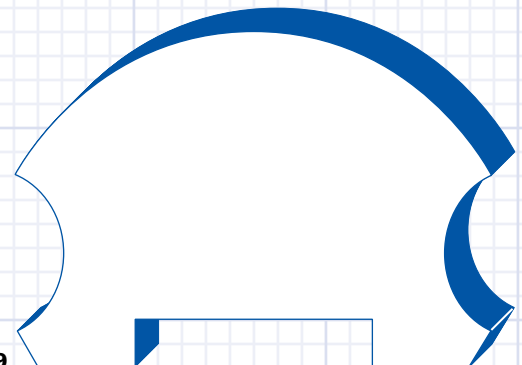

OR9

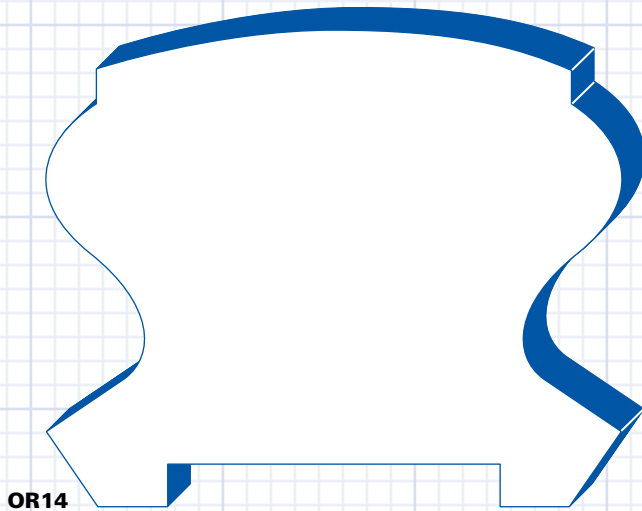

OR14

**OR14**  
**Oak**  
 Washington Rail  
 3" (1 3/4" plow)

**OR22**  
**White Oak**  
 Hand Rail  
 1 1/16" x 2"

**OS12**  
**Oak**  
 Shoe  
 3/4" x 2 1/2" (1 1/4" plow)

**OS15**  
**Oak**  
 Shoe  
 3/4" x 2 1/2" (1 5/8" plow)

**OS16**  
**Oak**  
 Shoe  
 7/8" x 3 1/8" (1 3/4" plow)

**W6010**  
**White Oak**  
 Hand Rail  
 2 1/4"

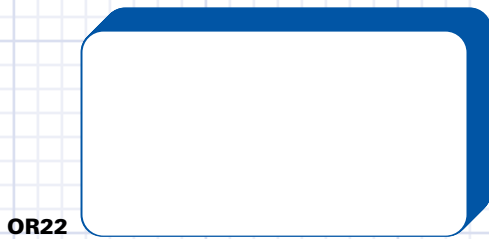

OR22



OS12

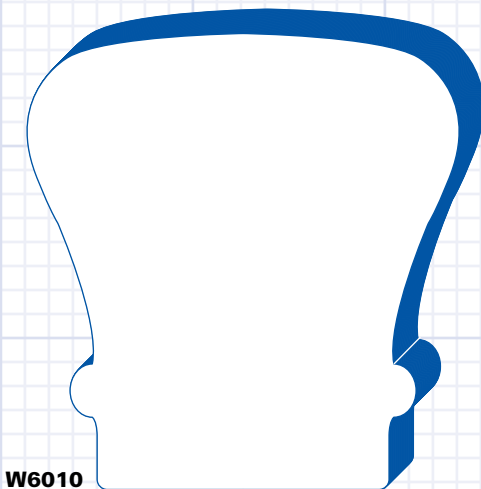

W6010

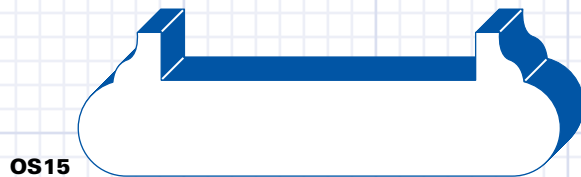

OS15

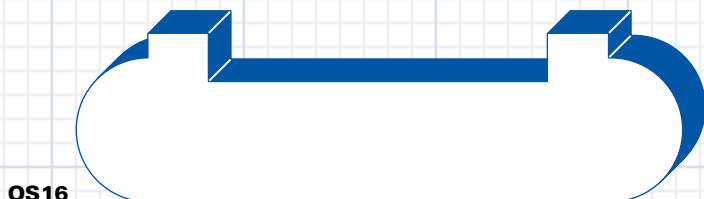

OS16

**A5R**  
**Redwood/Red Cedar\***  
 Casing  
 5/8" x 2 1/4"

**A8**  
**Redwood/Red Cedar\***  
 "Beaded" Casing  
 5/8" x 3 1/2"

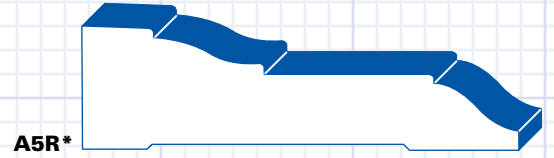

**A11**  
**Redwood/Red Cedar\***  
 Colonial Casing  
 5/8" x 4"

**A12R**  
**Redwood/Red Cedar\***  
 Victorian Casing  
 1 1/16" x 5 1/2"

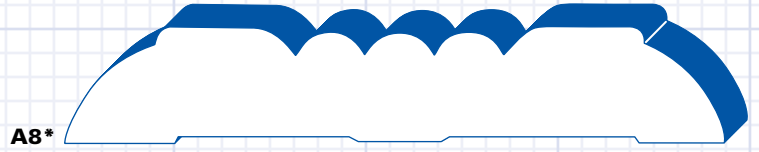

**A14R**  
**Redwood/Red Cedar\***  
 Victorian Step Casing  
 1 1/16" x 5 1/2"

**A15R**  
**Redwood/Red Cedar\***  
 OG Casing  
 1 1/16" x 5 1/2"

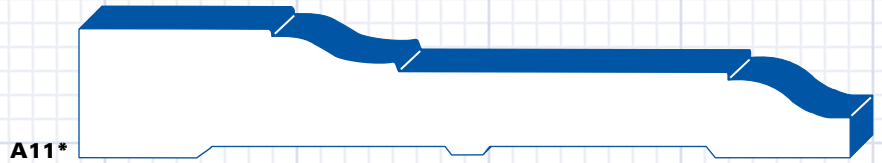

**A16R**  
**Redwood/Red Cedar\***  
 Bell Casing  
 1 1/16" x 5 1/2"

**\*PATTERN MAY ALTERNATE BETWEEN REDWOOD & RED CEDAR DEPENDING ON AVAILABILITY**

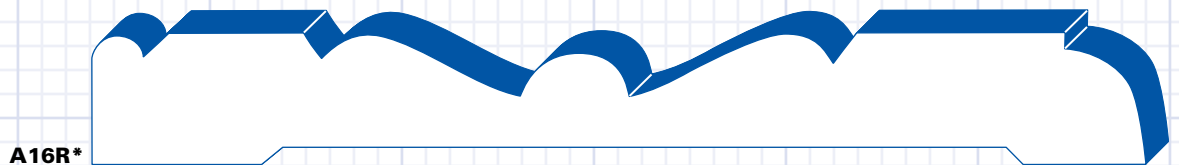
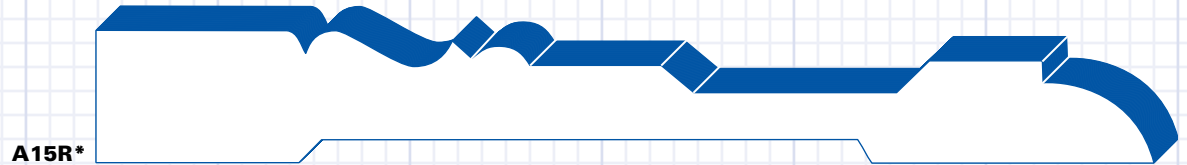
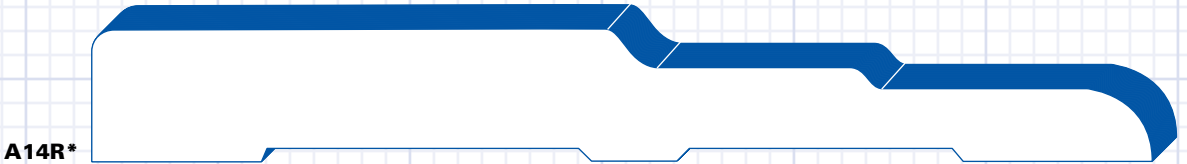
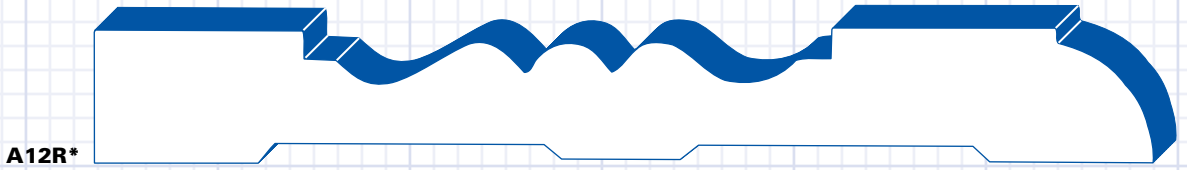



A22R

**A22R**

Redwood/Red Cedar  
MPB Casing  
*5/8" x 2 5/8"*



A24R

**A24R**

Redwood/Red Cedar  
AVB Casing  
*5/8" x 3 1/2"*

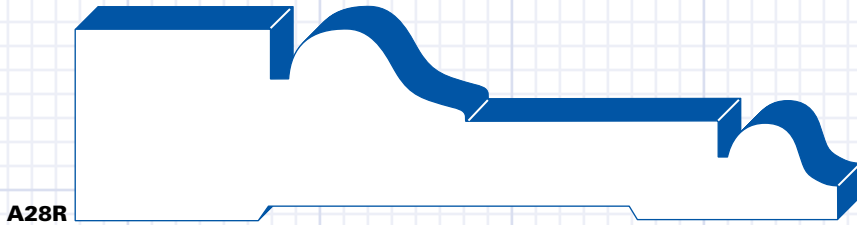

A28R

**A28R**

Redwood/Red Cedar  
Powell & Beach Casing  
*1" x 4"*

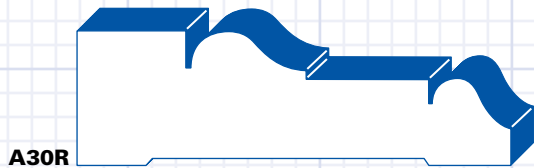

A30R

**A30R**

Redwood/Red Cedar  
Augusta Casing  
*1 1/16" x 2 1/4"*

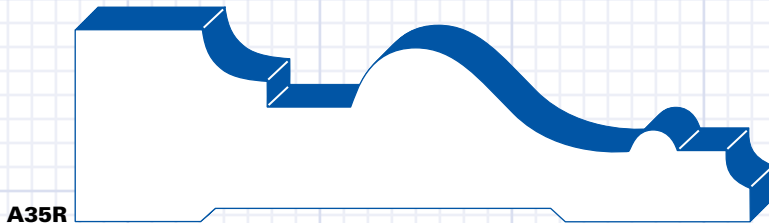

A35R

**A35R**

Redwood/Red Cedar  
Power Casing  
*1" x 3 1/2"*

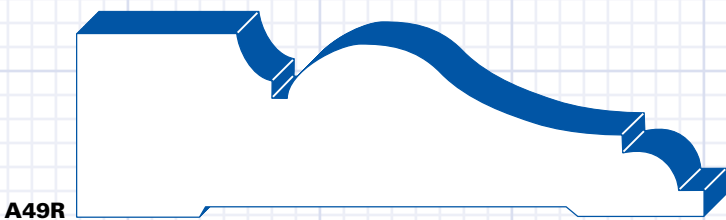

A49R

**A49R**

Redwood/ Red Cedar  
Sir Ivor Casing  
*1" x 3 1/2"*

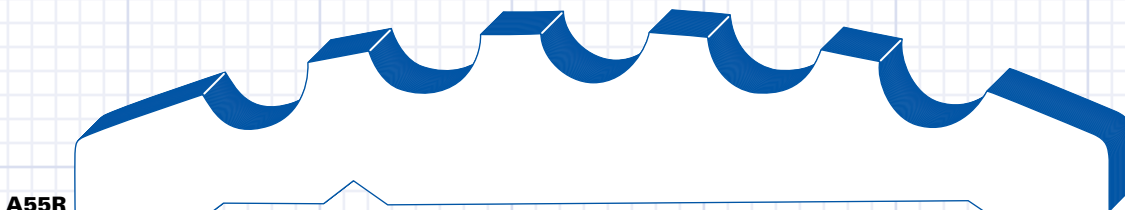

A55R

**A55R**

Redwood/Red Cedar  
Fluted Casing  
*1" x 5 1/2"*



**B2**  
Redwood/Red Cedar  
CAH Crown Moulding  
5 1/4"

**B3R**  
Redwood/Red Cedar  
Crown Moulding  
3 5/8"

**B6R**  
Redwood/Red Cedar  
Cove Moulding  
3/4" x 3/4"

**B8**  
Redwood/Red Cedar  
Bed Moulding  
2 3/4"

**B9**  
Redwood/Red Cedar  
Header Cap  
1 1/2" x 2 1/4"

**B12**  
Redwood/Red Cedar  
"Beaded" Cove  
1 5/16" x 2 1/8"

**B13R**  
Redwood/Red Cedar  
Crown  
1 1/16" x 4 1/4"

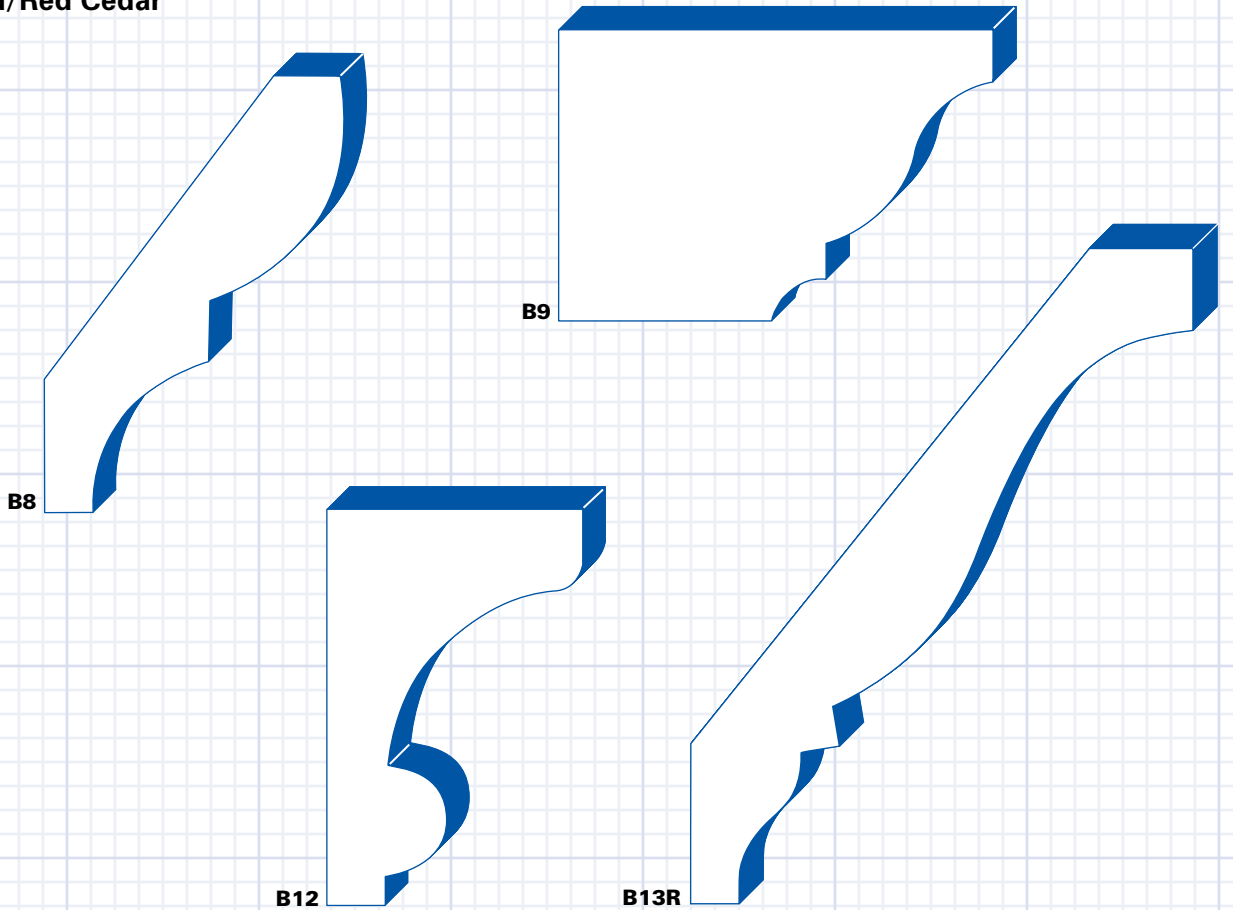
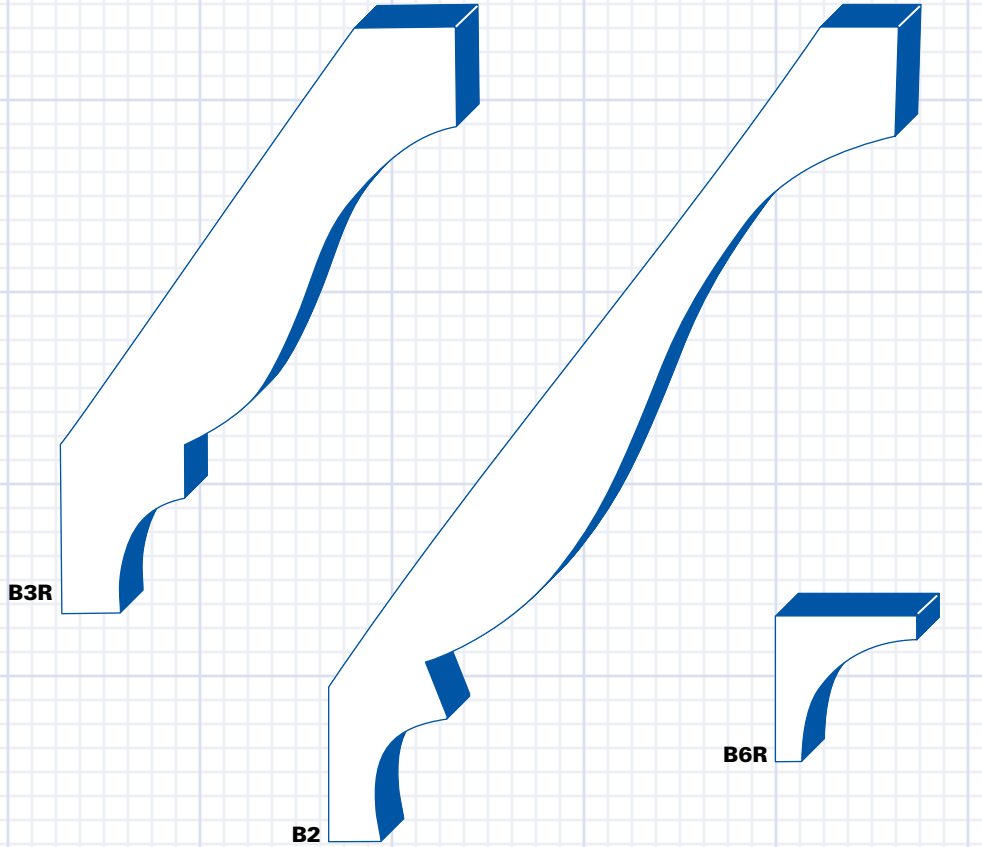

**B18J**  
 Redwood/Red Cedar  
 Ovolo Crown  
 5 1/2"

**B19J**  
 Redwood/Red Cedar  
 Cove  
 5 1/2"

**B23R**  
 Redwood/Red Cedar  
 Crown  
 3 1/8"

**B29R**  
 Redwood/Red Cedar  
 Alydar Crown  
 1" x 1 1/2"

**B36**  
 Redwood/Red Cedar  
 Ballymoss Cove  
 1 1/2" x 1 1/2"

**B38**  
 Redwood/Red Cedar  
 Piggott Crown  
 1 1/2" x 1 1/2"

**B39**  
 Redwood/Red Cedar  
 Cove  
 1" x 1"

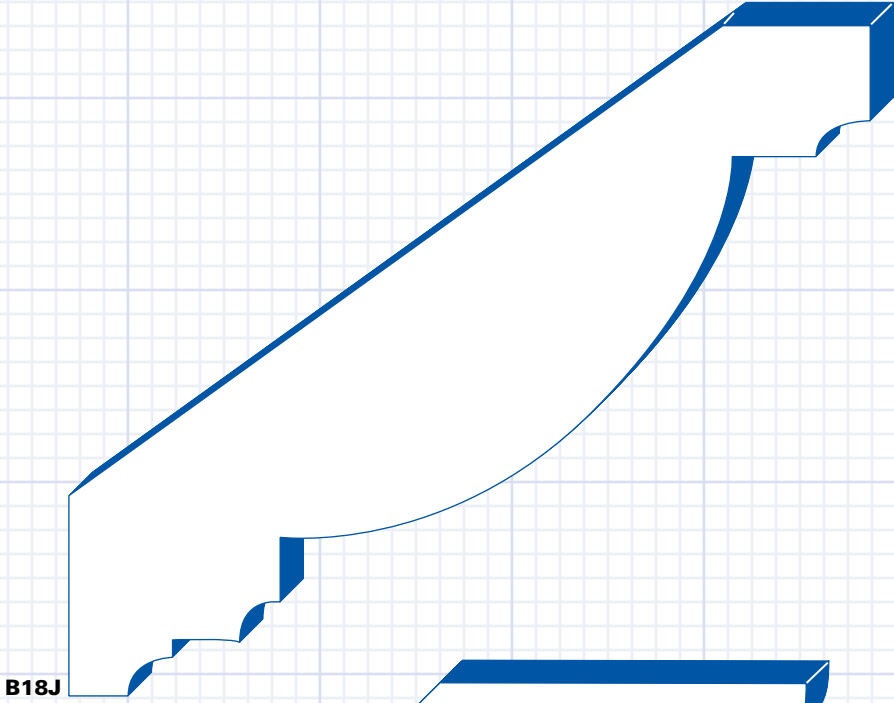

B18J

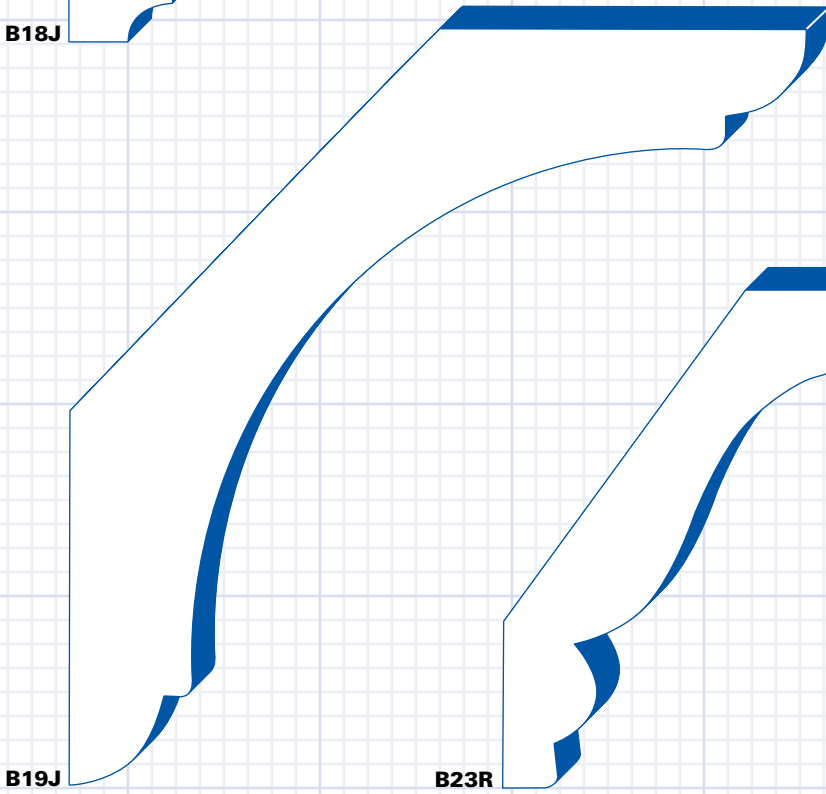

B19J

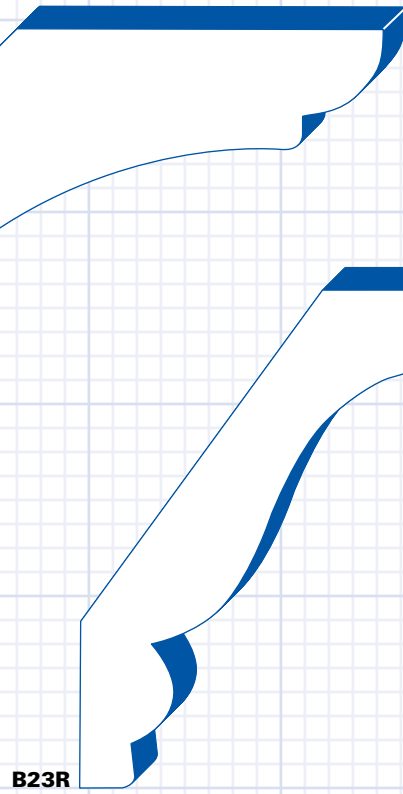

B23R

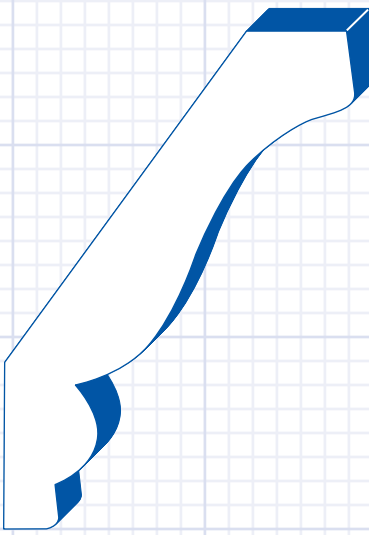

B29R

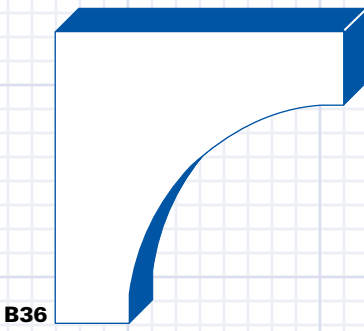
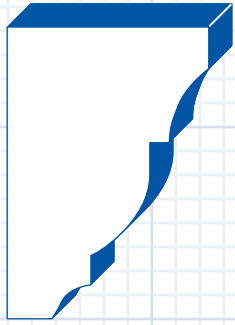

B36

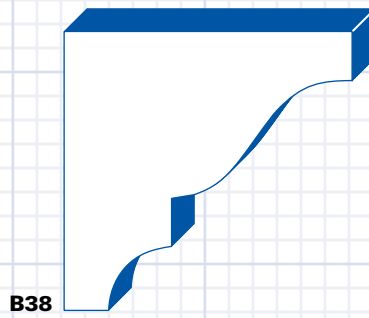

B38

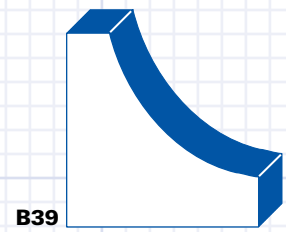

B39

**B45**

Redwood/Red Cedar

Crown  
 $1\frac{3}{8}'' \times 2\frac{11}{16}''$

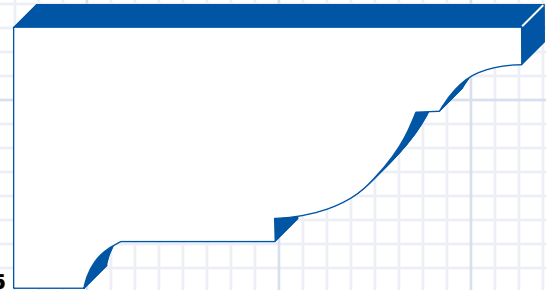

B45

**C8R**

Redwood/Red Cedar

Base Cap  
 $1\frac{1}{16}'' \times 1\frac{3}{8}''$



C8R

**C32R**

Redwood/Red Cedar

Longdon Cap  
 $1'' \times 1\frac{3}{4}''$



D10R

**D10R**

Redwood/Red Cedar

OG OS Stop S4S  
 $1\frac{1}{2}'' \times 1\frac{1}{2}''$

**E4**

Redwood/Red Cedar

Victorian Stucco  
 $1'' \times 1\frac{3}{4}''$

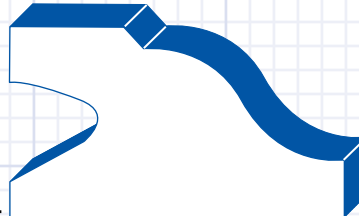

E4

**E5R**

Redwood/Red Cedar

Panel Moulding  
 $\frac{5}{8}'' \times 1''$

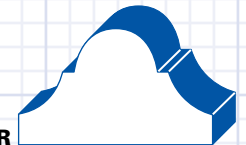

E5R

**E6J**

Redwood/Red Cedar

Shingle Moulding  
 $1\frac{1}{16}'' \times 1\frac{9}{16}''$

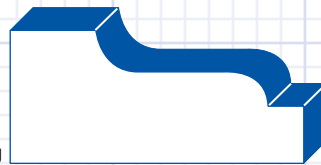

E6J

**E7**

Redwood/Red Cedar

Stucco  
 $1'' \times 1\frac{9}{16}''$



E7

**E14J**

Redwood/Red Cedar

Dublin Stucco  
 $1'' \times 3''$

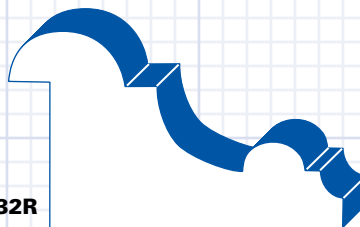

C32R

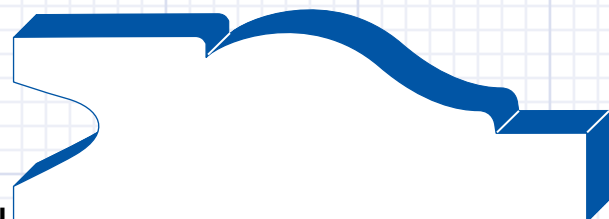

E14J

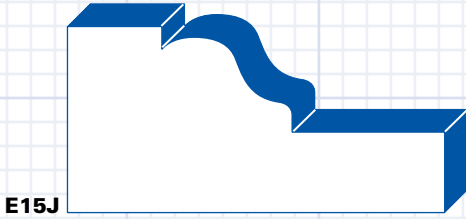

E15J



E15K

**E15J**  
Redwood/Red Cedar  
Brick Moulding  
1" x 2"

**E15K**  
Redwood/Red Cedar  
Brick Moulding (Keyed)  
1" x 2"

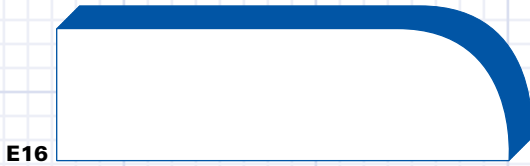

E16

**E16**  
Redwood/Red Cedar  
Garage Stop  
1 1/16" x 2 3/8"

**E17K**  
Redwood/Red Cedar  
Brick Moulding (Keyed)  
1 1/4" x 2"

**E17R**  
Redwood/Red Cedar  
Brick Moulding  
1 1/4" x 2"

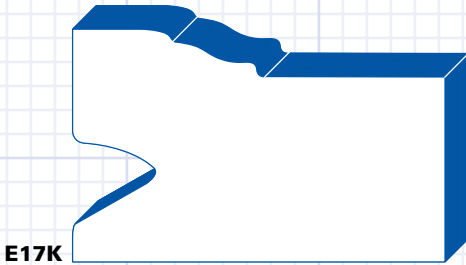

E17K

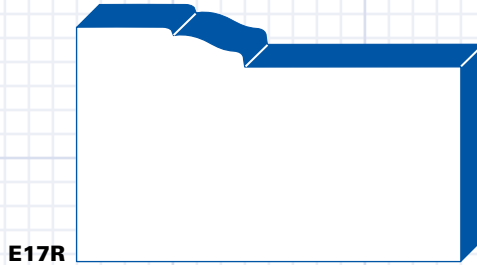

E17R

**E20-4**  
Redwood/Red Cedar  
Bevel Cap  
1 3/8" x 3 1/2"

**E20-6J**  
Redwood/Red Cedar  
Bevel Cap  
1 3/8" x 5 1/2"

**E20-8**  
Redwood/Red Cedar  
Bevel Cap  
1 3/8" x 7 1/4"  
not shown

**E20-10**  
Redwood/Red Cedar  
Bevel Cap  
1 3/8" x 9 1/4"  
not shown

**E20-12**  
Redwood/Red Cedar  
Bevel Cap  
1 3/8" x 11 1/4"  
not shown

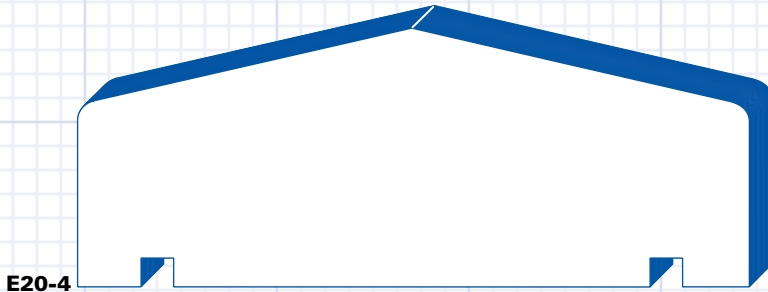

E20-4

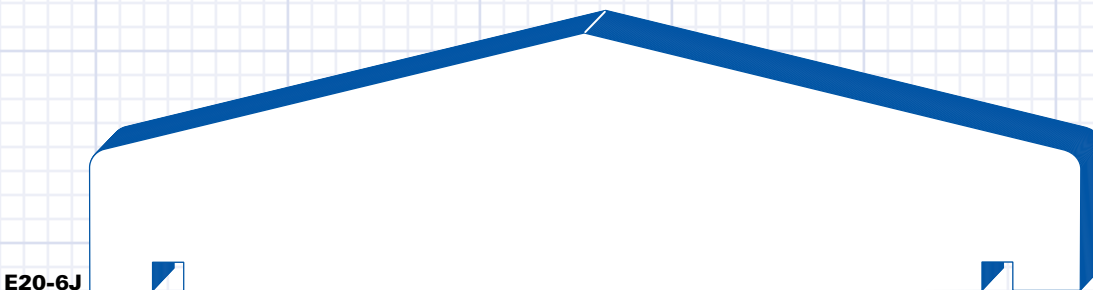

E20-6J

**F5R**

Redwood/Red Cedar  
Square Stop  
*3/4" x 3/4"*

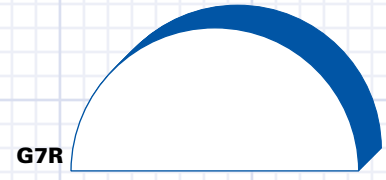
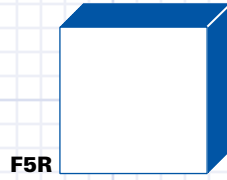

**G7R**

Redwood/Red Cedar  
Half Round  
*1 1/2"*

**G10R**

Redwood/Red Cedar  
Quarter Round  
*3/4" x 3/4"*

**G13**

Redwood/Red Cedar  
Quarter Round  
*1 1/2"*

**G16**

Redwood/Red Cedar  
Quarter Round  
*1" x 1"*

**G18**

Redwood/Red Cedar  
Corner Bead  
*5/8" x 7/8"*

**H4**

Redwood/Red Cedar  
O/S Rustic Plug  
*5/16" x 1 3/8"*

**H7**

Redwood/Red Cedar  
Cove Rustic Plug  
*5/16" x 1 3/8"*

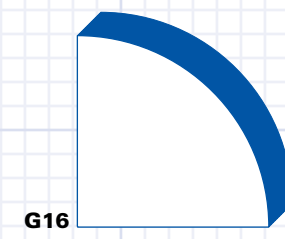
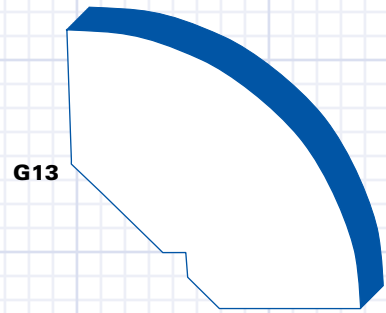
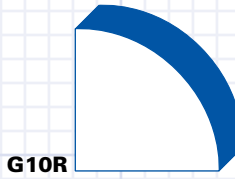

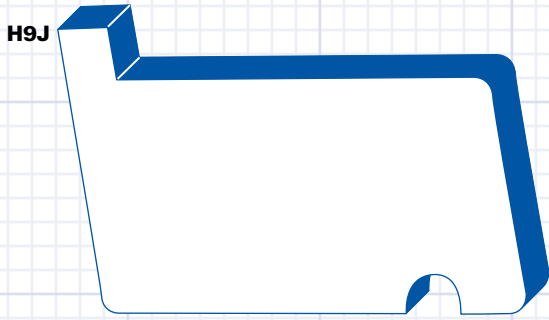

H9J

**H9J**  
 Redwood/Red Cedar  
 Water Table  
 1 1/2" x 2 1/2"

**H18**  
 Redwood/Red Cedar  
 Sash Stool  
 1 7/16" x 5 1/8"

**I10**  
 Redwood/Red Cedar  
 Sill  
 2" x 8"  
 net size 1 1/2" x 7 1/4"

**MR14**  
 Cedar  
 Rail  
 2 3/4" (1 3/8" plow)

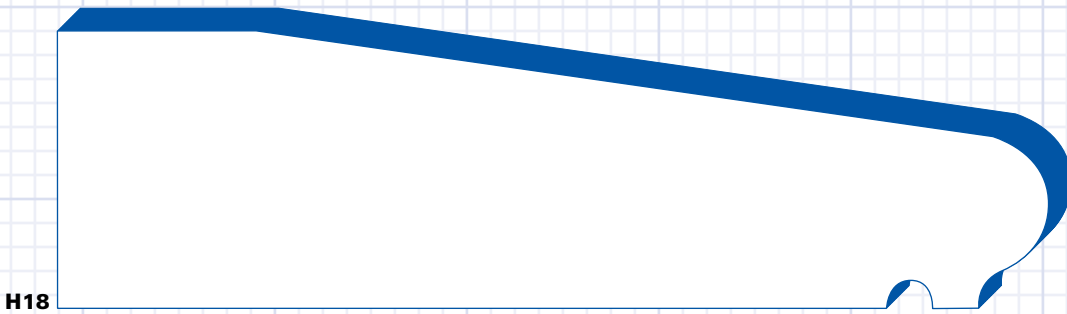

H18

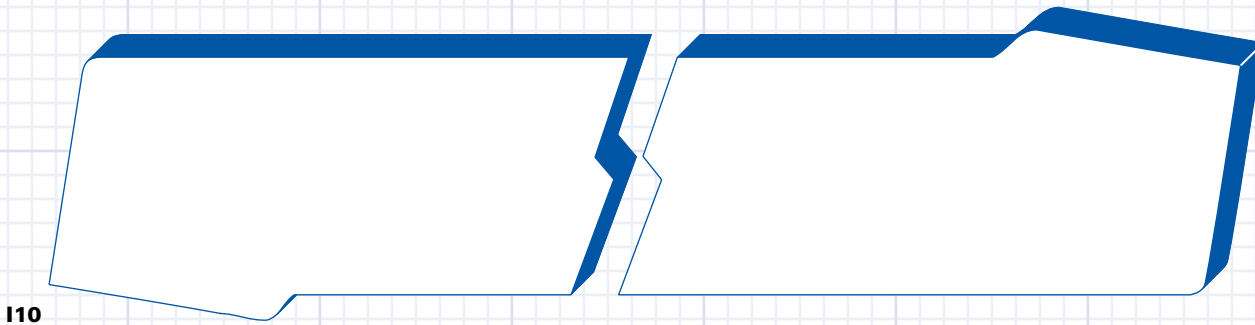

I10

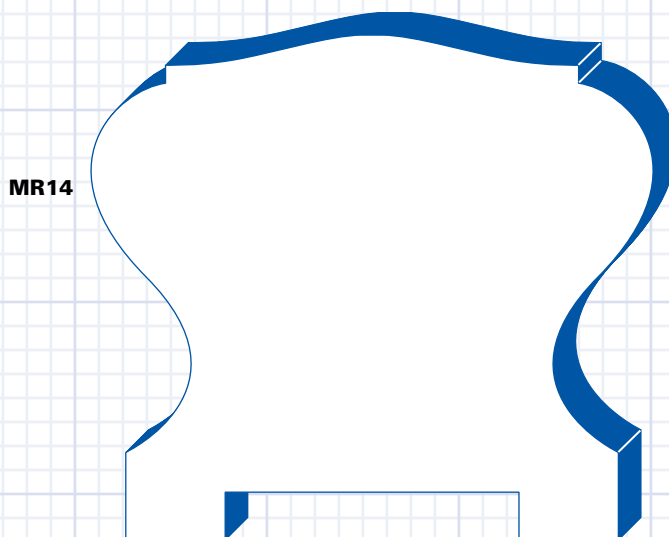

MR14

**FR4A**

**Redwood/Red Cedar**  
 Rail Cap  
 4"



**FR4B**

**Redwood/Red Cedar**  
 Rail Side  
 1" x 3"  
 (For use with 3" x 3" Baluster)  
 1" x 4"  
 (For use with 4" x 4" Baluster)

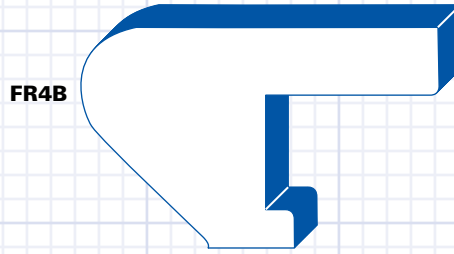

**FR5R**

**Redwood/Red Cedar**  
 Mushroom Plowed Rail  
 1 1/2" x 2 1/4"

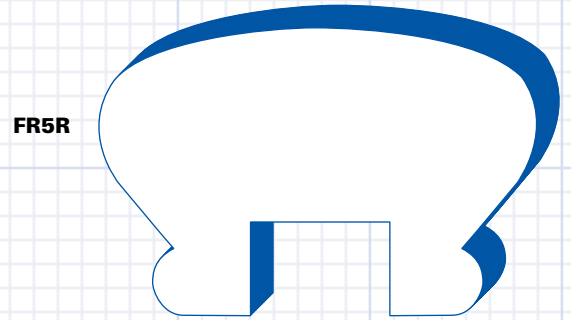

**FR9A**

**Redwood/Red Cedar**  
 Handrail  
 1/2" x 2 1/4"

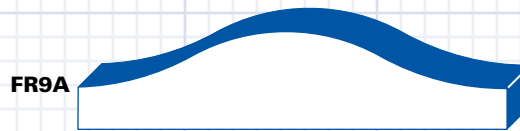

**FR9B**

**Redwood/Red Cedar**  
 Handrail  
 1 1/2" x 3 1/2"



**FR9F**

**Redwood/Red Cedar**  
 Foot Rail  
 1 1/2" x 3 1/2"

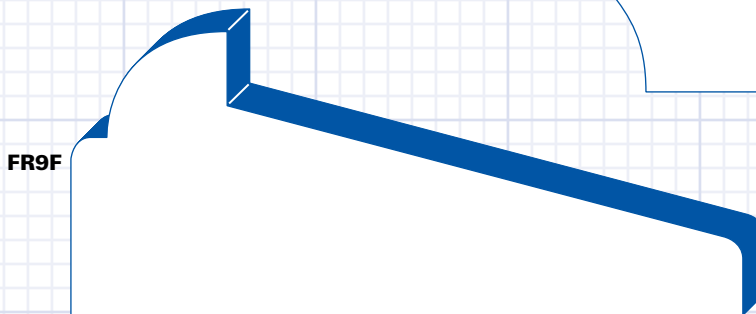

**FR10A**

**Redwood/Red Cedar**  
 Handrail  
 3/4" x 3 5/8"

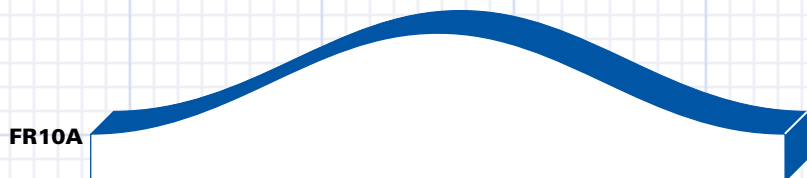

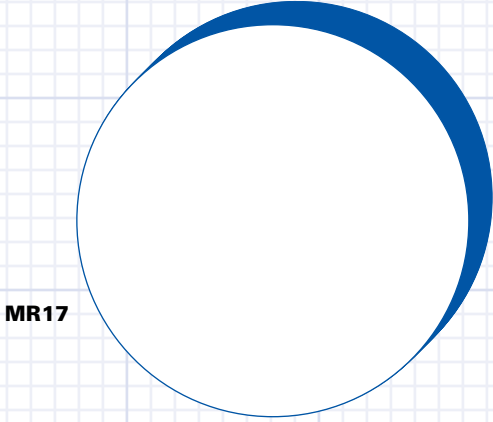

MR17

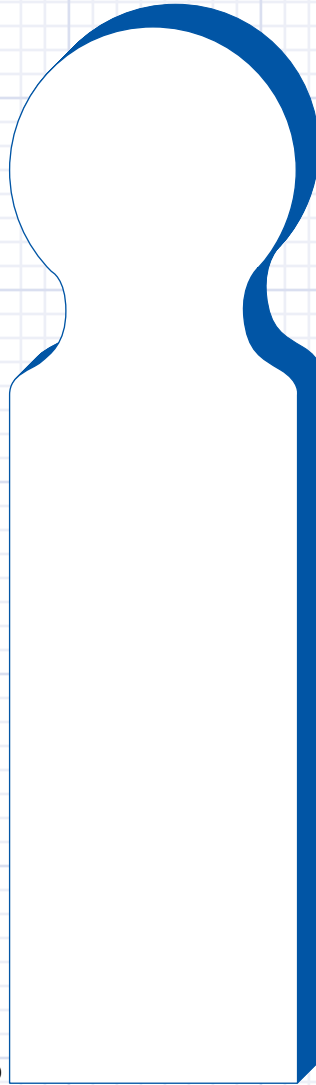

MR20

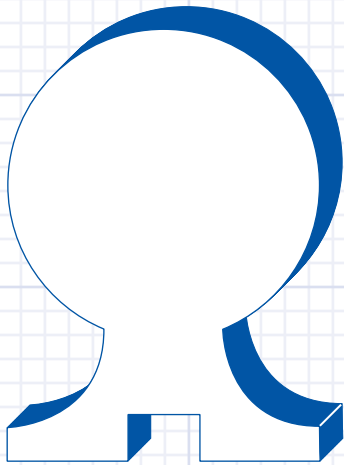

MR32

**FR10B**  
Redwood  
Handrail  
1 1/2" x 5"

**FS31**  
Cedar  
Shoe Rail  
7/8" x 3 1/8" (1 1/2" plow)

**MR17**  
Redwood/Red Cedar  
Handrail  
2"

**MR20**  
Redwood  
Handrail  
5 1/2" x 1 1/2"

**MR32**  
Redwood/Red Cedar  
Rail  
2 1/4" x 1 5/8"

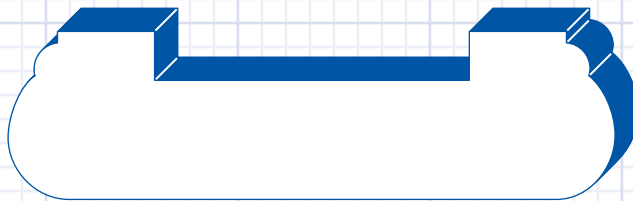

FS31



FR10B



Window Casing

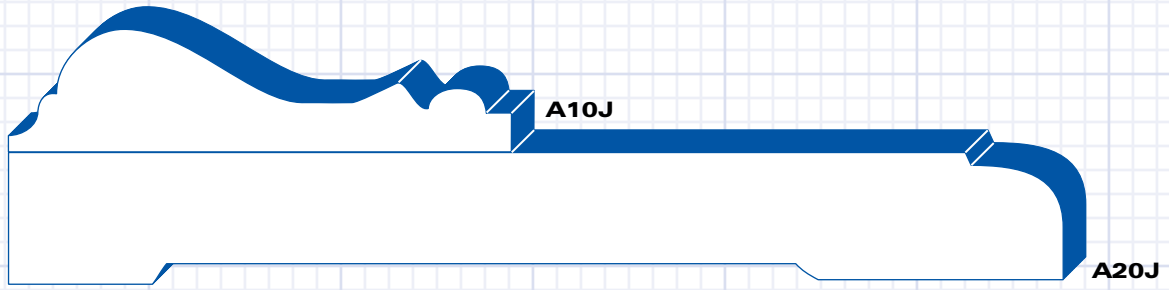

Window Sill

H1J

Window Casing

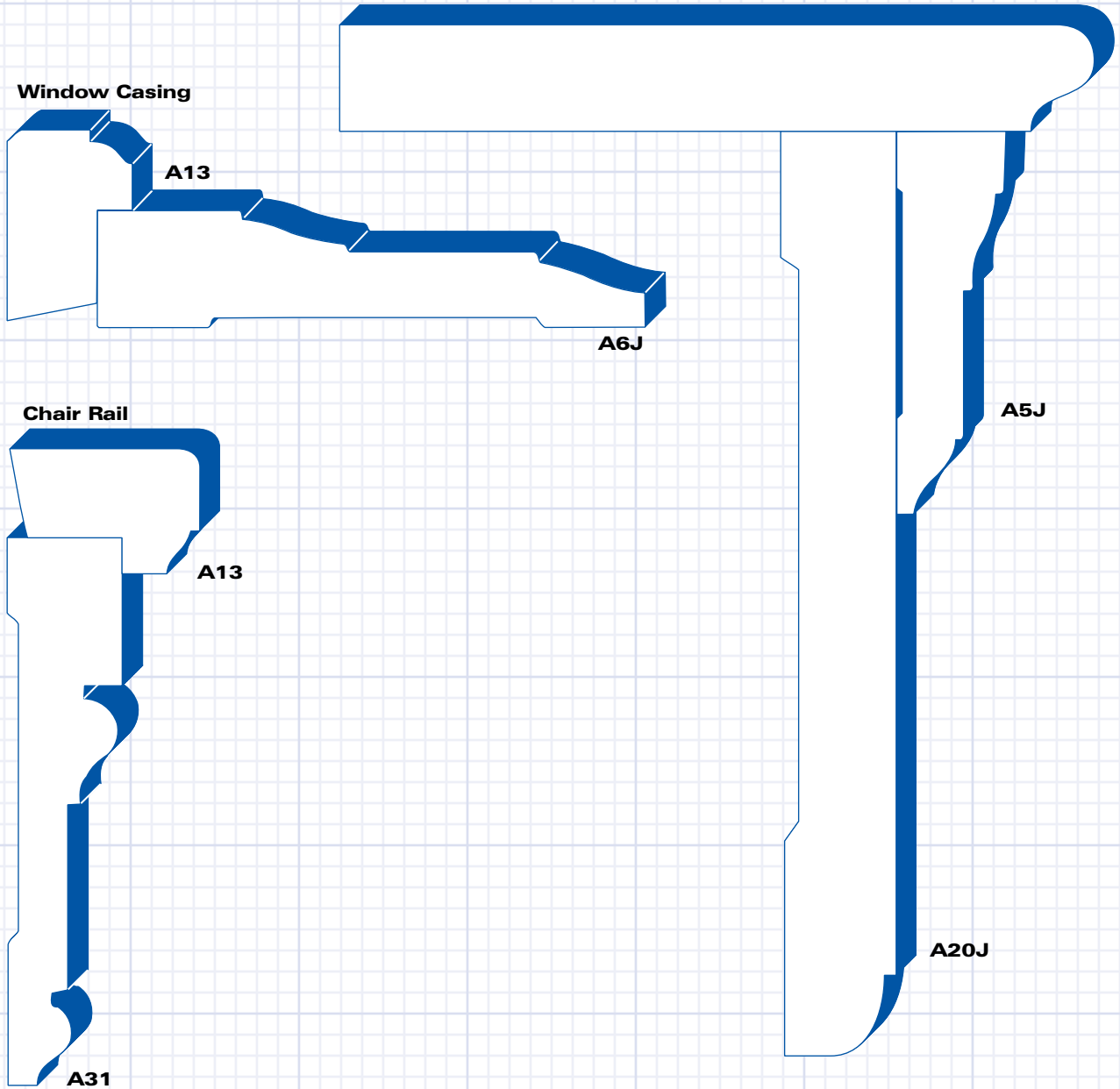

Chair Rail

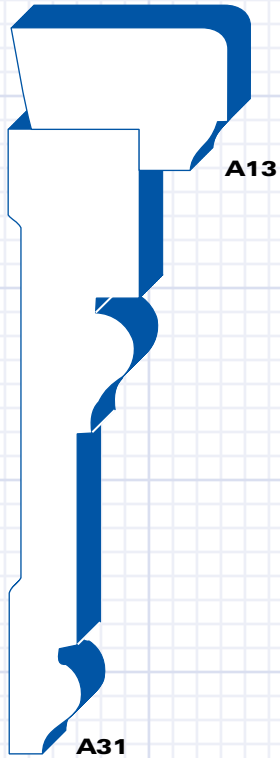

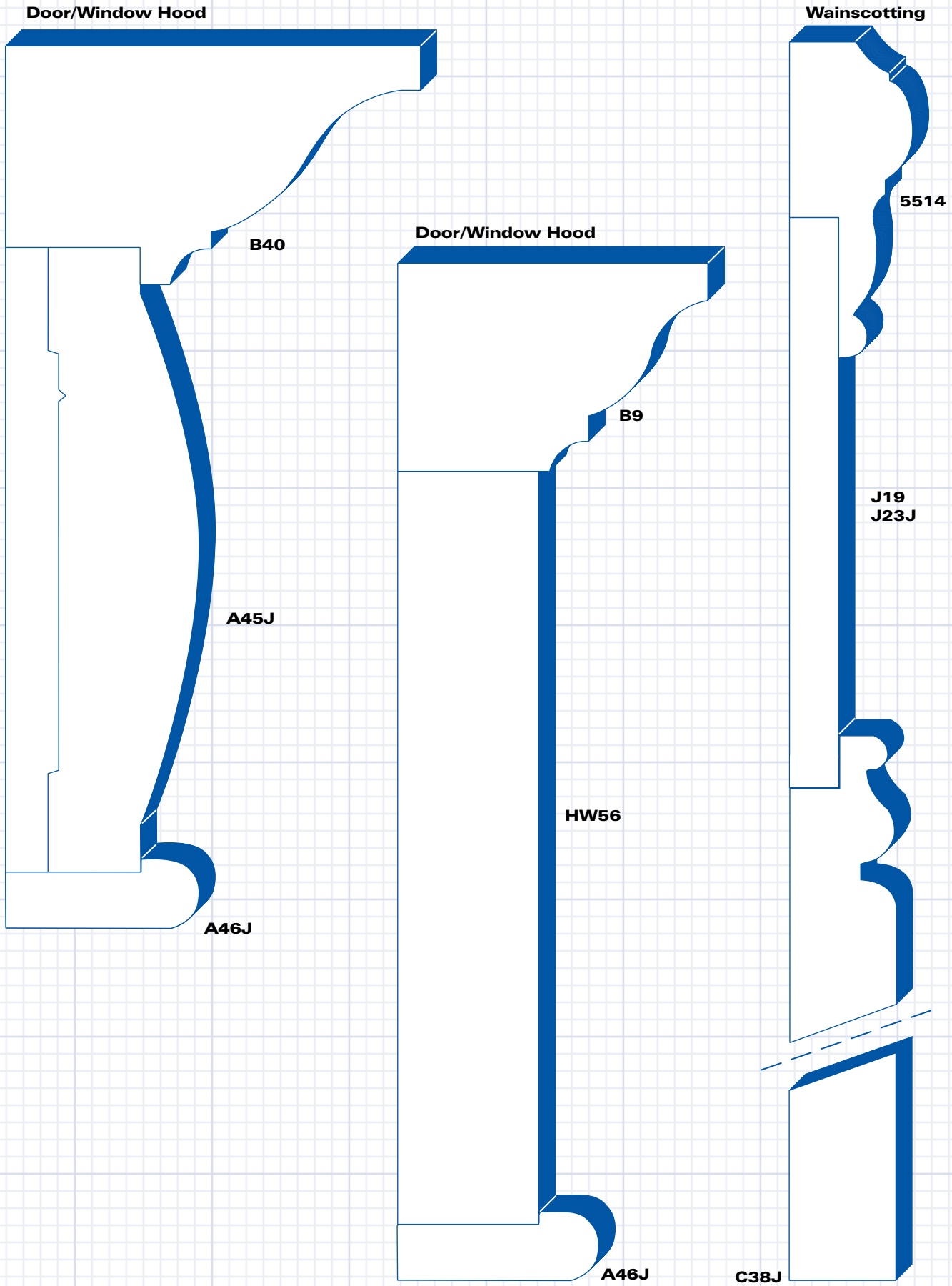

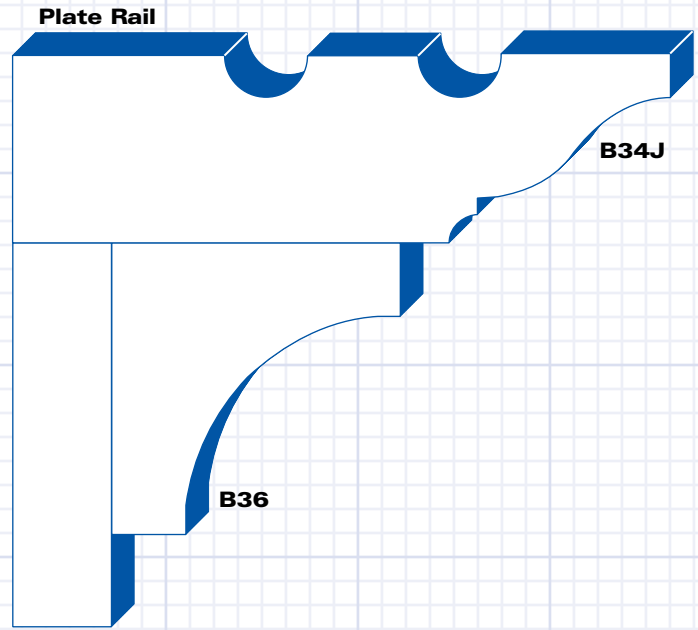
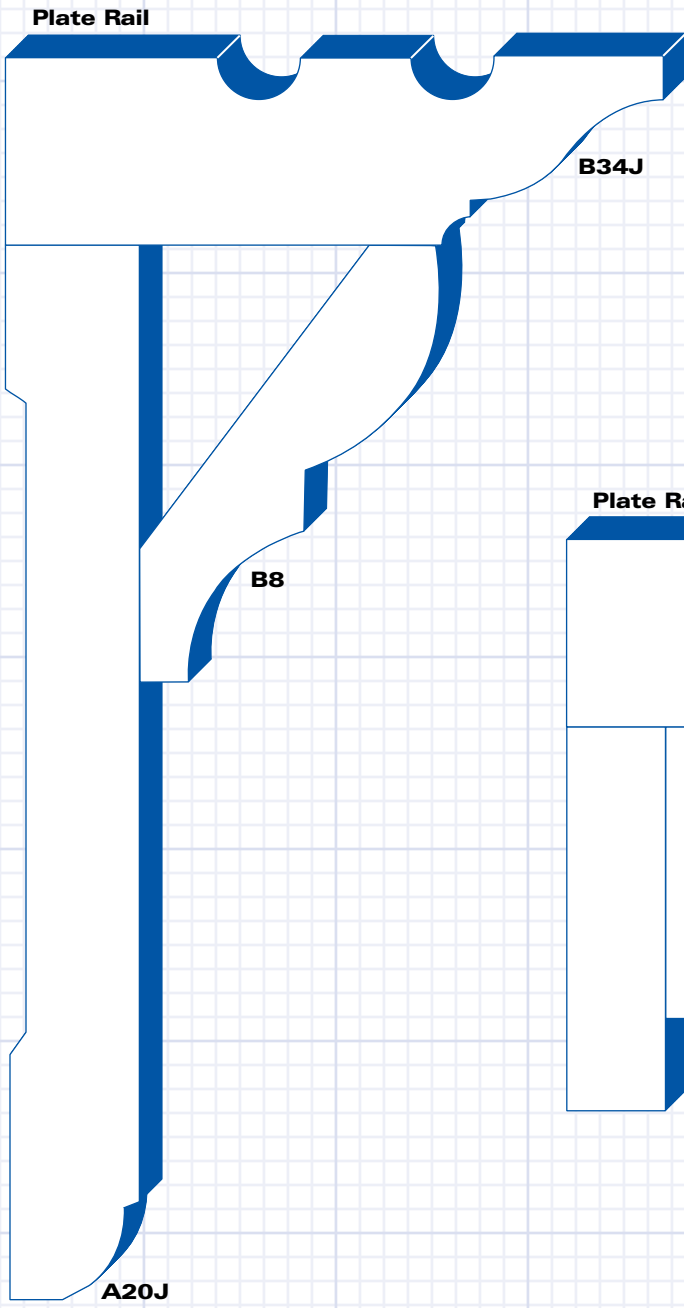

Base Buildup

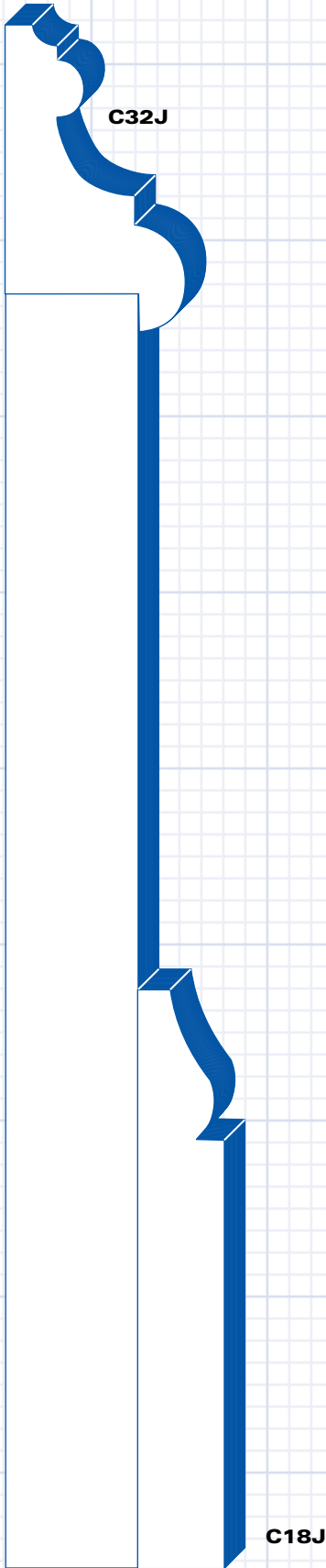

Base Buildup

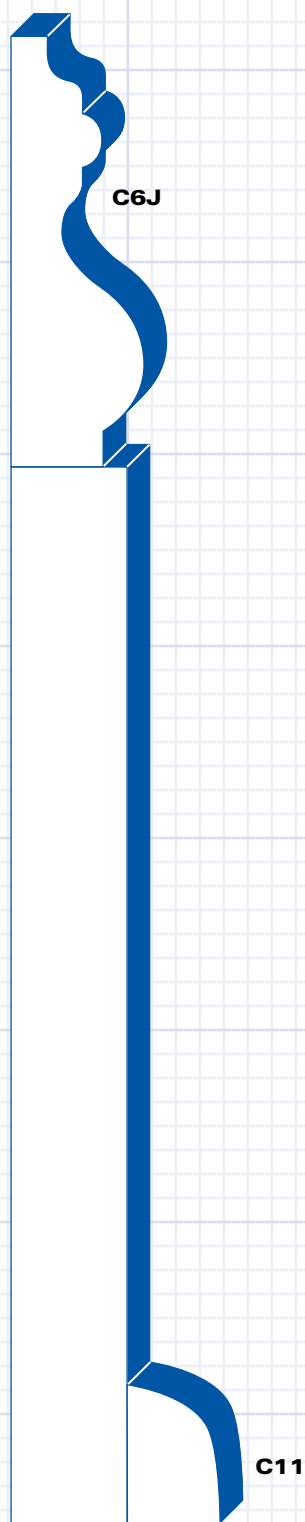

Baseboard 2-Piece

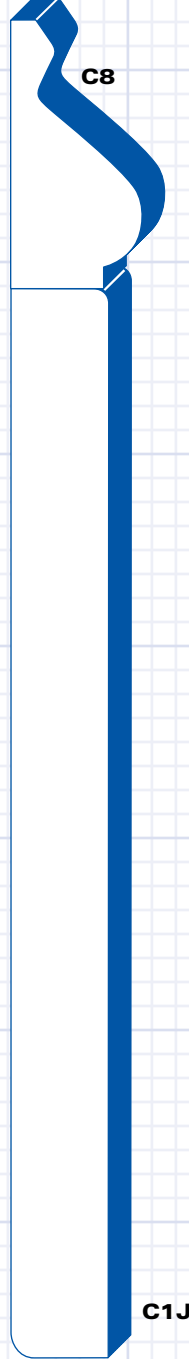

Baseboard  
*(scaled to fit)*

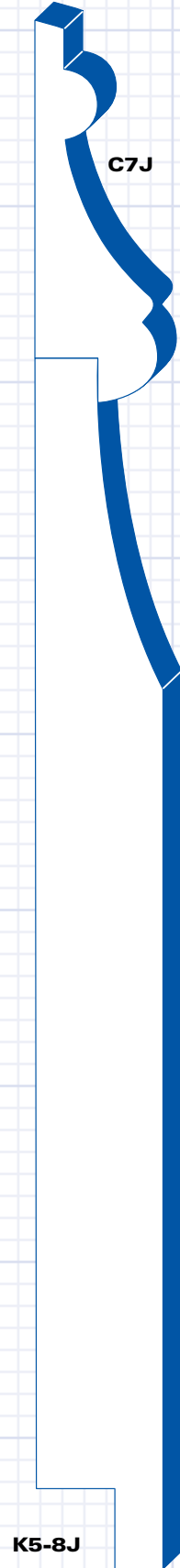

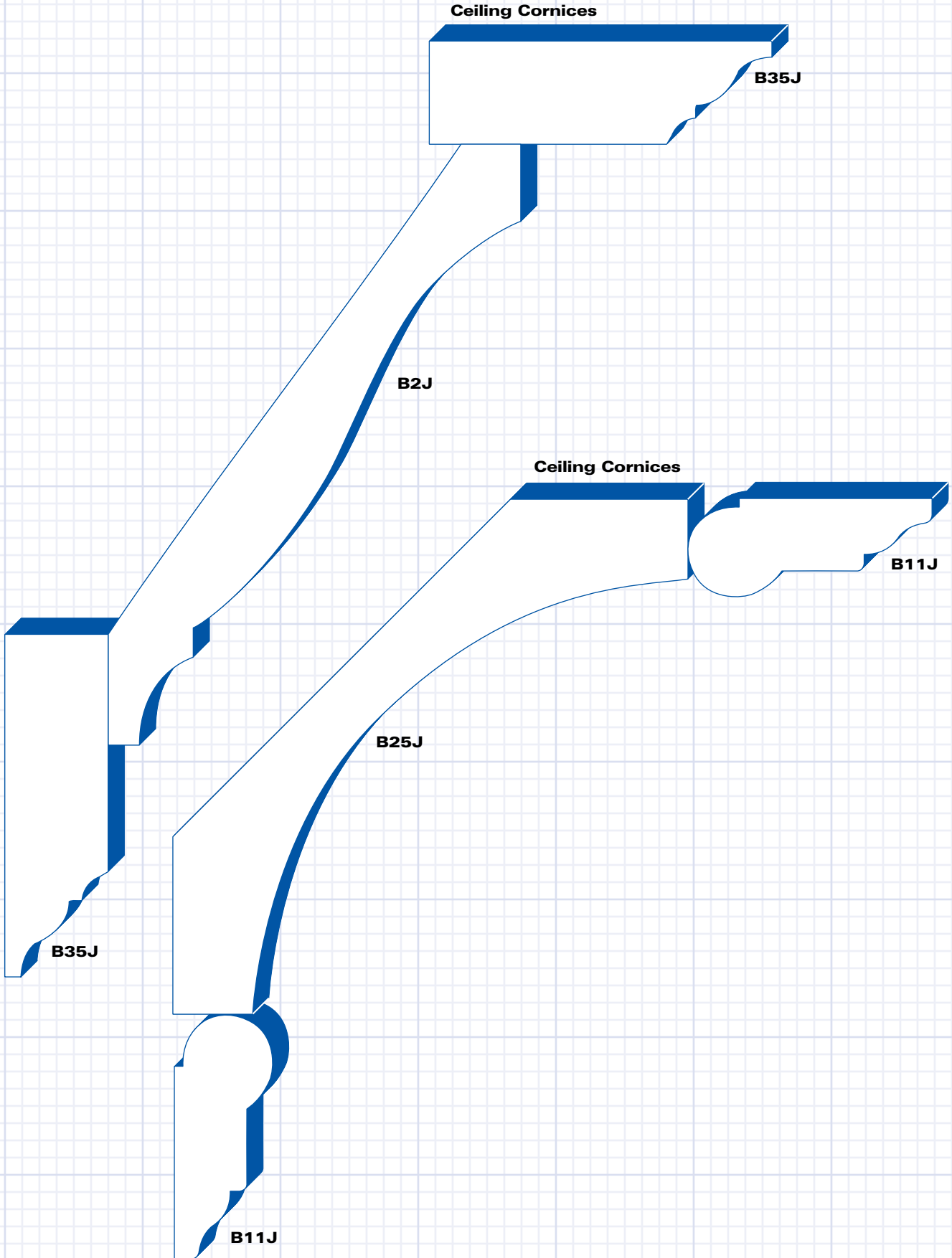

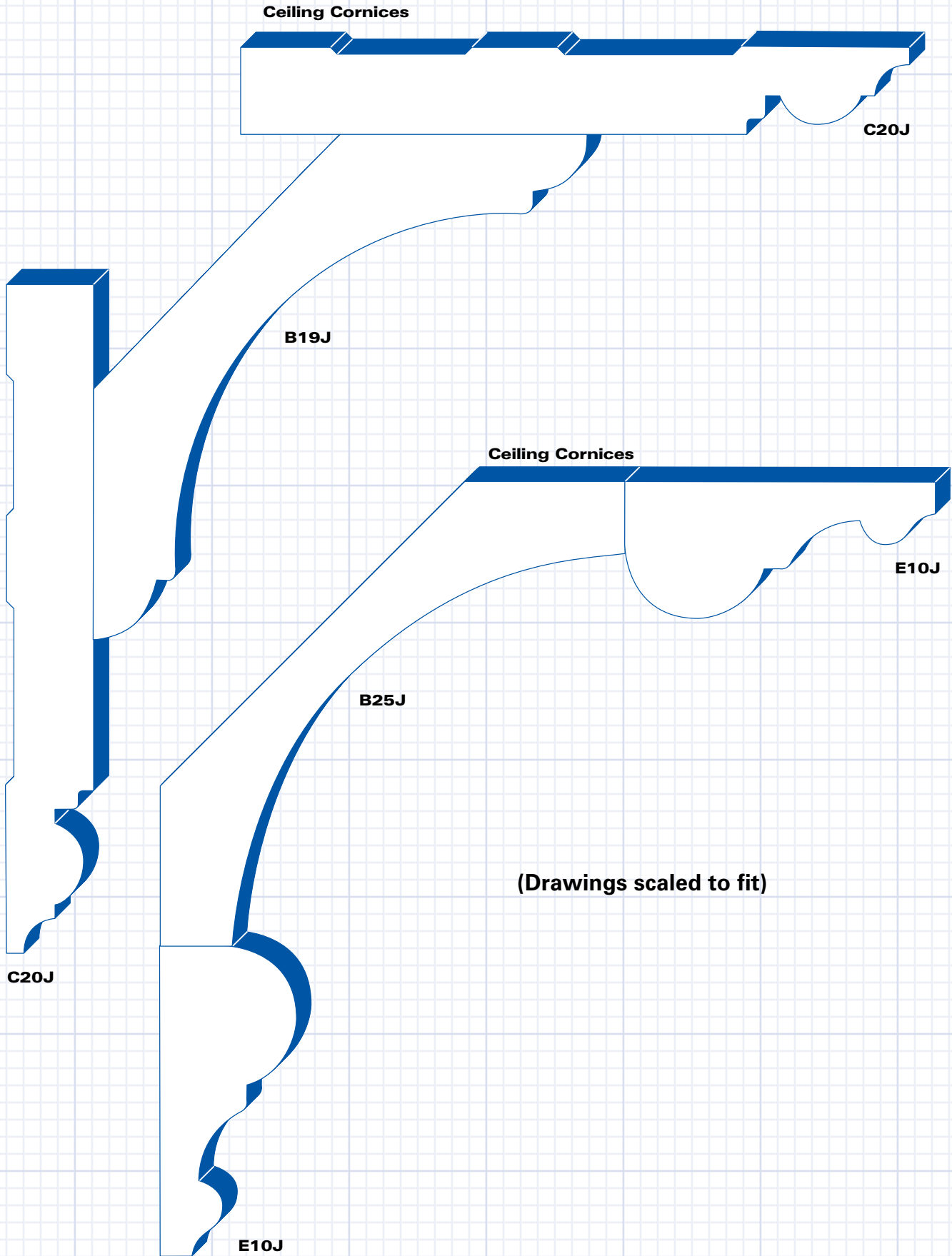

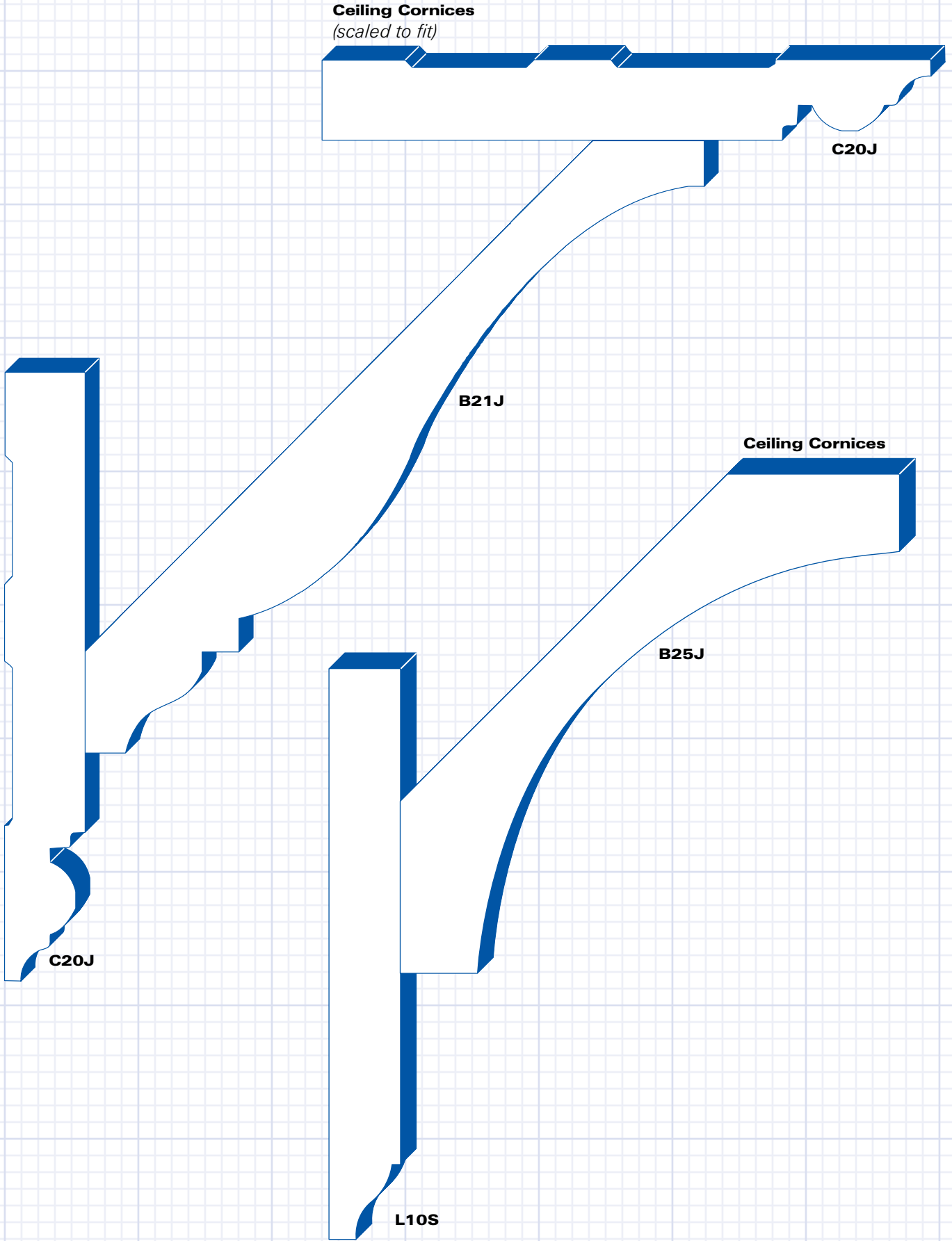

**Ceiling Beam**  
*(scaled to fit)*

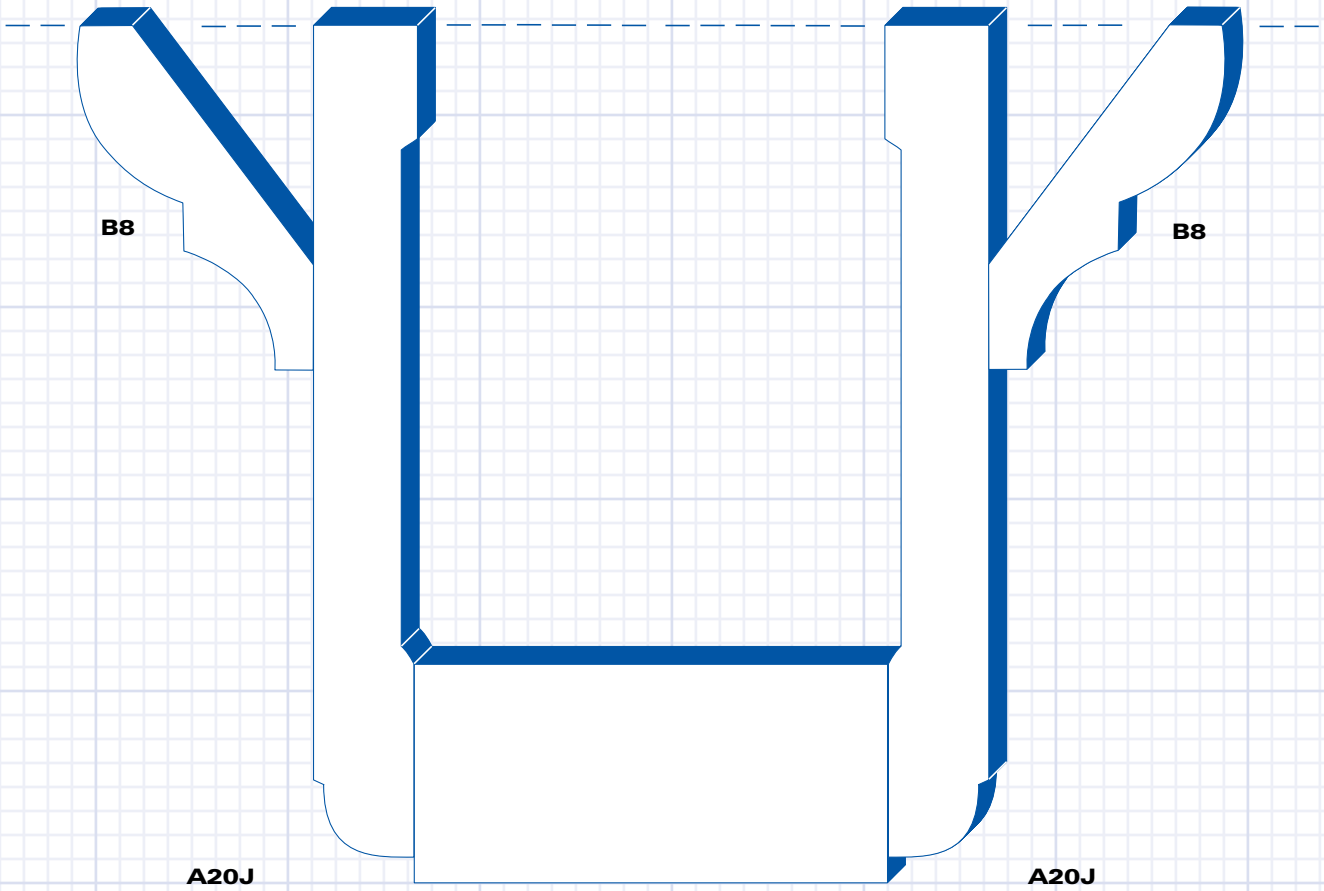



**BERONIO LUMBER** is pleased to carry a collection of Classic American Mouldings from Windsor Mill. This series contains four distinct and defining American House Period styles, including:

## The Classical Colonial Style

The Classical Colonial Style captures the flair and flavor of the 18th century and is designed after the mouldings in the historic William Gibbes House in Charleston, South Carolina, where the walls and rooms were symmetrical, balanced and perfectly proportioned.

Mouldings of this period were quite sturdy, and the Classical Colonial Style reproduces the size and scale of these traditional patterns. Typical of this period, the Style is built up and large, with bold details designed to create a home of distinctive scale.

This Classical Colonial Style is drawn from turn of the century millwork and accurately captures the spirit of early craftsmanship, where house-wrights would use a variety of hollow, round and angled planes to mold fine-grained wood according to their own interpretation of traditional design. Detailed coves and beads throughout the mouldings result in a harmonious and classic pairing of styles perfect for any home.

## The Classical Craftsman Style

Representing an influential presence in American architectural history, the Classical Craftsman Style is inspired by the Arts and Crafts, Bungalow and Prairie movements. These movements rejected Victorian era excesses and embraced the desire to emphasize “man-made” over “machine-made” materials.

Simple square lines with rounded edges, the mouldings from the Classical Craftsman Style are thick and hearty. In a time when most mouldings have shrunk in size and thickness, these mouldings stand boldly. Reviving the craftsmanship from decades before, this offering emphasizes clean, simple design and detailed workmanship.

The classical side of this Style is seen in the header cap, with the doors and windows reflecting the lines of the classical crown. Clean lines and classical details, taken directly from period moulding catalogs, make these mouldings versatile for a variety of homes.

## The Greek Revival Style

Amidst growing patriotism and a decreasing dependency on England, a new architectural movement called the Greek Revival emerged in America. It was embraced by influential pattern book authors Asher Benjamin and Minard Lafever, architects of the early 1800's and contemporaries of Charles Bullfinch. Benjamin was one of our earliest and most famous architects. Best known for his pattern books, Benjamin's writings and engravings were popular and widely distributed in the Northeast from 1810 to the mid 1830's.

Inspired by the democratic ideals of Greek culture and using the Parthenon as a model, architecture of this period reflected ideals of symmetry and balance. Increasing interest in decorative mouldings resulted in subtle details being added to the home's windows, doors, mantels and staircases in addition to traditional room mouldings.

The moulding profiles of this Style maintain the elliptical lines of Greek architecture, giving them a subtle shadow line and refined look.

## The Colonial Revival Style

Capturing the spirit of classical details on a smaller scale and the revival of old world styles, the Colonial Revival Style reflects a new interpretation of classical orders with a distinctively American feel. Historic styles unique to colonial architecture found new life during the 1920's and 1930's, as architecture began to increasingly reflect the homeowner's wealth. A renewed sense of national pride arrives, and along with it comes a revival of a classical architectural style that is slightly smaller in scale, and just as eye-catching.

Taken from a turn of the century moulding catalog, patterns of this Style use mostly 3/4" material tied together meticulously for a feeling of detailed grandeur perfect for today's style of homes. Particularly notable in the collection is the picture moulding, with a turn of the century crown treatment to create a classical symbol when placed a few inches beneath the crown.

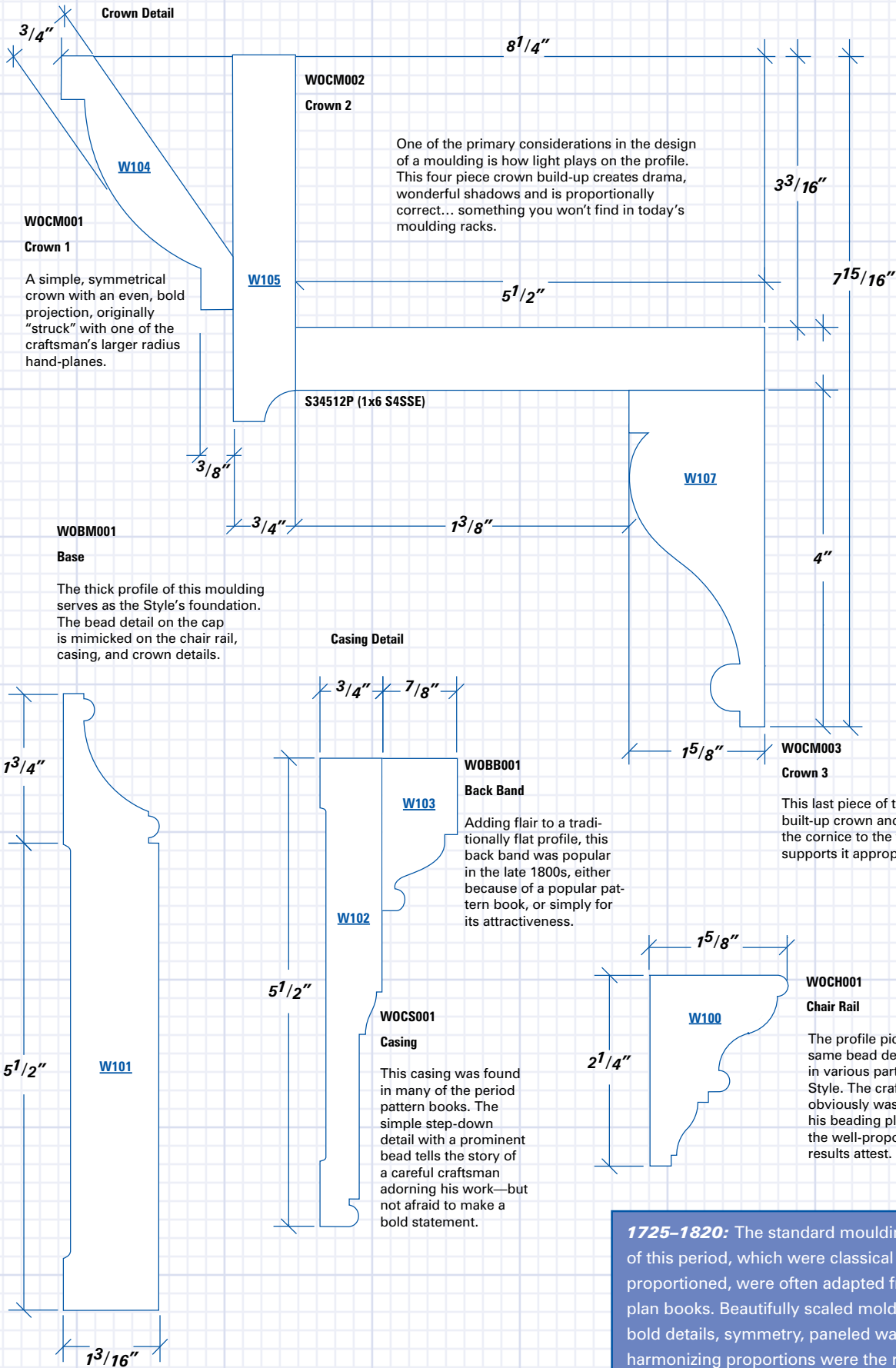

**1725–1820:** The standard moulding patterns of this period, which were classical and evenly proportioned, were often adapted from London plan books. Beautifully scaled moldings, bold details, symmetry, paneled walls and harmonizing proportions were the rule.

*\*images not shown to scale*

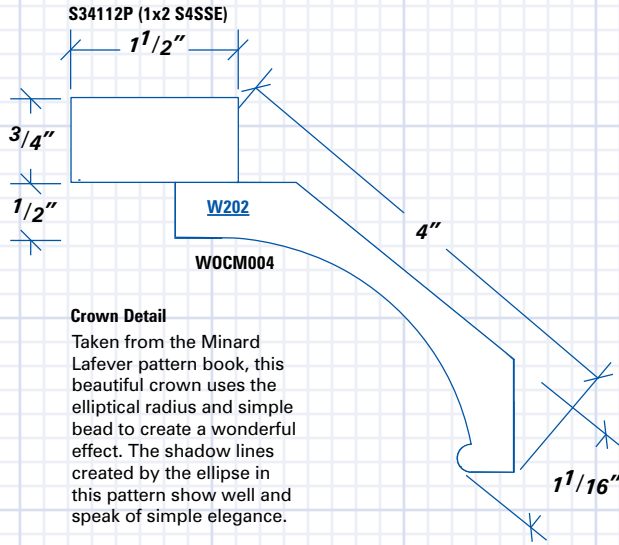

**Crown Detail**  
Taken from the Minard Lafever pattern book, this beautiful crown uses the elliptical radius and simple bead to create a wonderful effect. The shadow lines created by the ellipse in this pattern show well and speak of simple elegance.

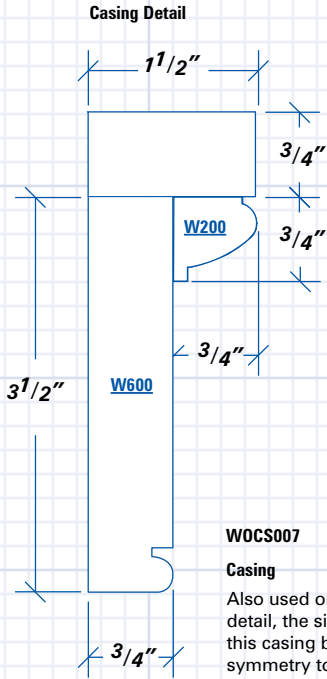

**S34112P (1x2 S4SSE)**  
This simple, square back band is seen in catalogs and pattern books from the 1820s through the 1870s.

**WOCB002**  
**Band Moulding**  
Inspired by an Asher Benjamin pattern book of the 1830s, this elliptical band mold was used extensively in Greek Revival houses.

**WOCM004**  
**Casing**  
Also used on the window detail, the simple bead on this casing brings order and symmetry to the room.

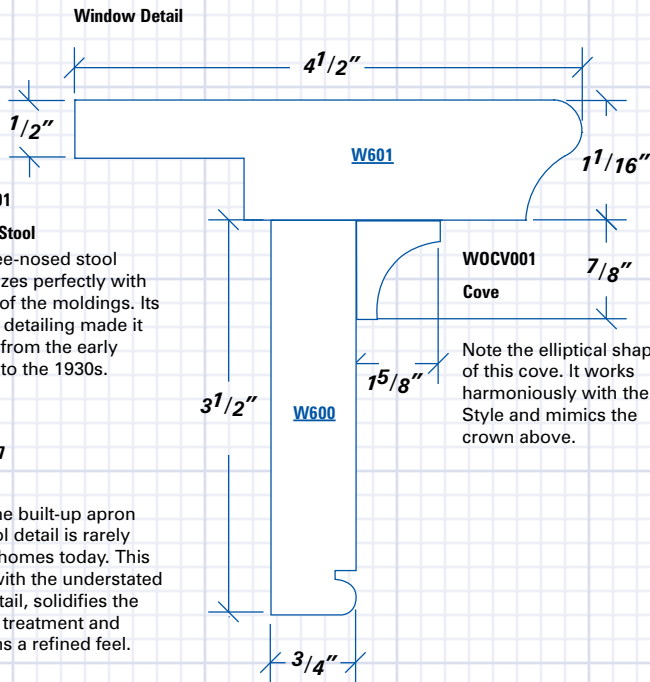

**WOWS001**  
**Window Stool**  
This ogee-nosed stool harmonizes perfectly with the rest of the moldings. Its graceful detailing made it popular from the early 1800s into the 1930s.

**WOCM004**  
**Apron**  
Sadly, the built-up apron and stool detail is rarely used in homes today. This apron, with the understated bead detail, solidifies the window treatment and maintains a refined feel.

Note the elliptical shape of this cove. It works harmoniously with the Style and mimics the crown above.

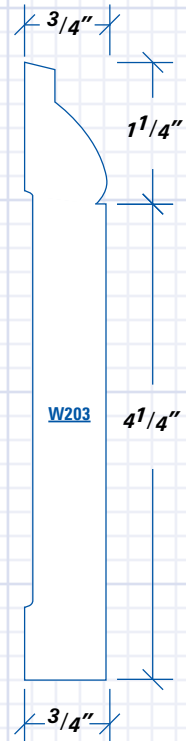

**WOBM002**  
**Base Moulding**  
This classically inspired base moulding anchors the Greek Revival Style. The harmonious play of light on the ovolo and deep set quirk bring order and elegance to the entire piece.

**1820-1840:** Inspired from the pattern books of the great architect Asher Benjamin, the Greek Revival Style is based on the oval instead of the circle. It is believed the Greeks used the nautilus shell as a model architectural profile.

\*images not shown to scale

**Crown**

This straightforward crown with an ogee top establishes the mood for this Style. The moulding combines the simple styling of the Arts and Crafts movement with the classicism of the 1920s.

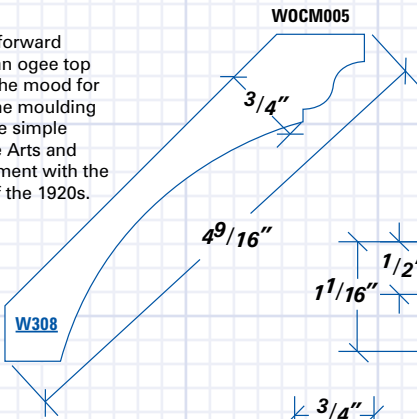

**Window Detail**

This stool and apron detail is an appropriate finish for any window. The thick stool is softened by the simple cove, which transitions to the apron. The result is a strong detail with handsome shadow lines and an honest feel.

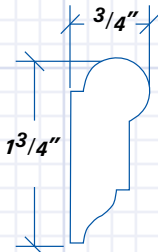
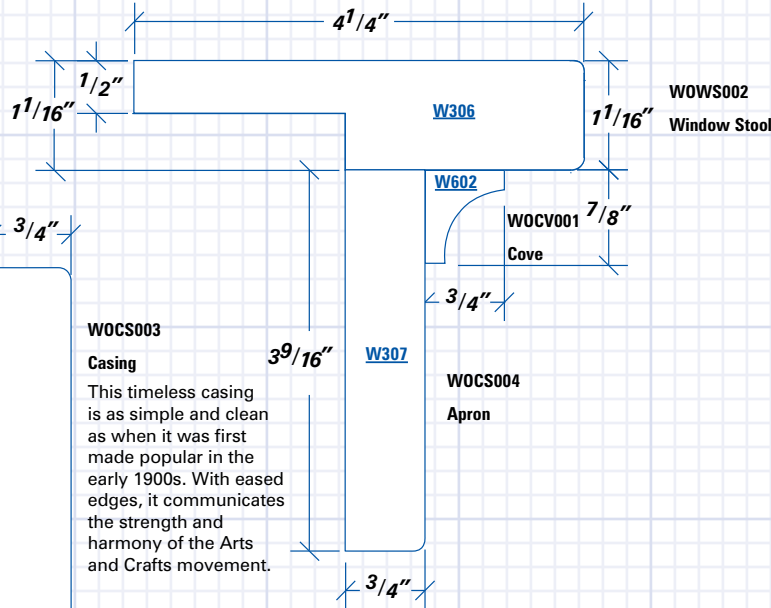

**WOPM004**

**Picture Moulding**

A great functioning piece of history. Not only was it used to hang pictures (plaster was too hard to nail into), but also by functioning as the architrave, it creates the feel of the classical entablature.

**WOCM003**

**Casing**

This timeless casing is as simple and clean as when it was first made popular in the early 1900s. With eased edges, it communicates the strength and harmony of the Arts and Crafts movement.

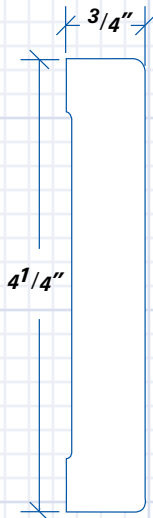

**1900–1930:** Rejecting the ornate mouldings that characterized the Victorian era, the Classical Craftsman Style reflects the ideals of the Arts and Crafts movement, with simple lines and unadorned details.

**WOPB001**

**Plinth**

The plinth block gets its name from classical architecture where the plinth supported the base of the column. This Classical Craftsman Style plinth is simple and substantial and works great in any room.

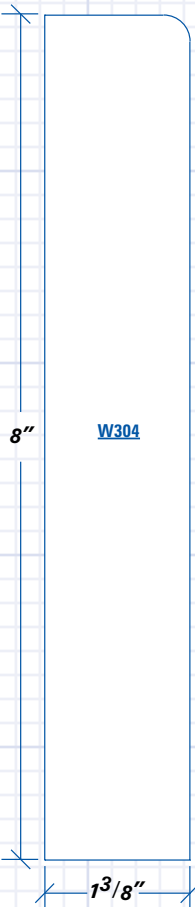

**WOBM003**

**Base Moulding**

This base also carries the Arts and Crafts message. Extra tall by today's standards, it works to ground the wall in an effortless fashion. Note how the shoe mold and the base together die perfectly into the edge of the plinth for a clean finish detail.

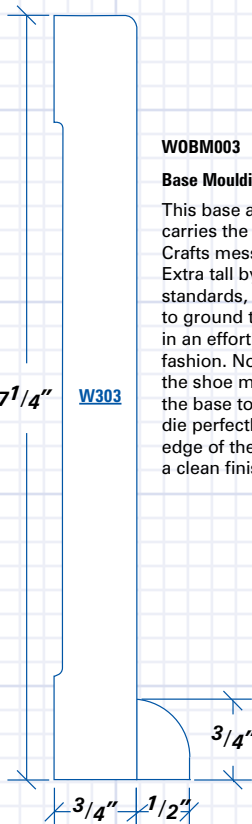

**WOBM003**

**Base Shoe**

This shoe mold and the base together die perfectly into the edge of the plinth for a clean finish detail.

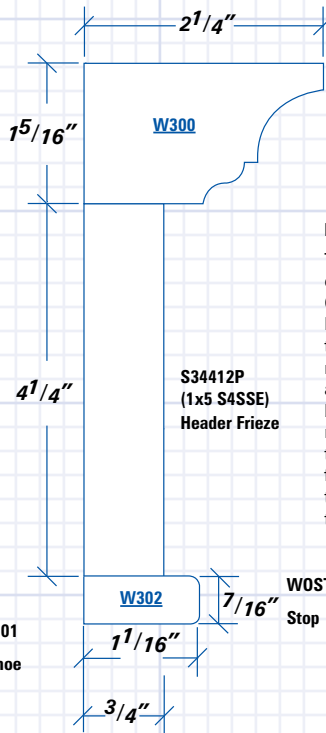

**WOHC001**

**Header Cap**

**Header Detail**

The cove and ogee elements in this three-part Classical Craftsman Style header cap complement the other mouldings in the room. The radius-stop piece at the bottom balances the build-up and feels like a mini-entablature, essential to the classical and clean feel of this Style. Note how the shadows splay across the large circular radius.

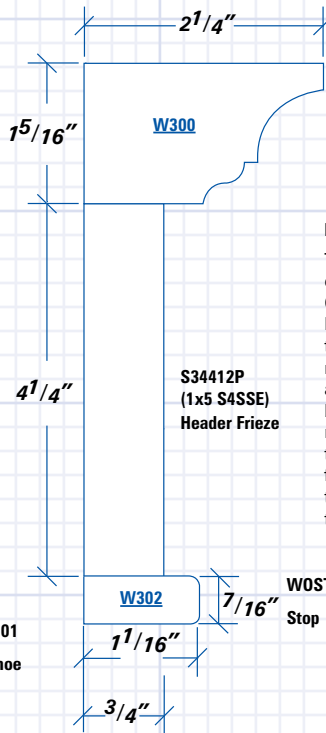

**S34412P (1x5 S4SSE)**

**Header Frieze**

**WOST001**

**Stop**

This stop piece is used to terminate the header detail.

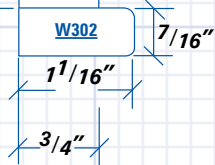

\*images not shown to scale

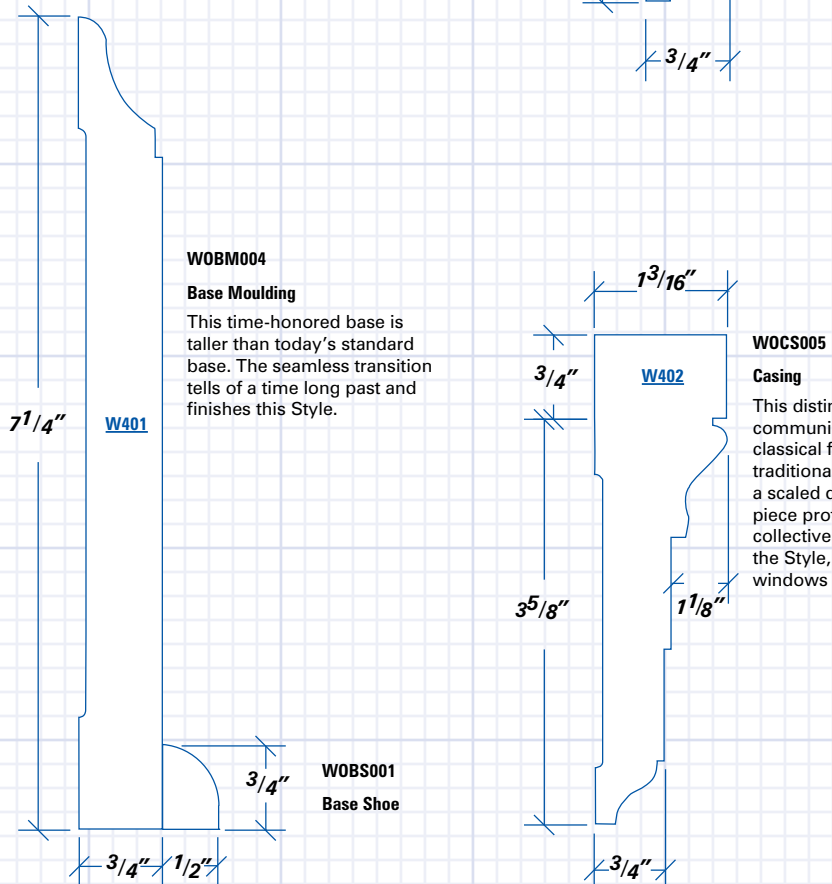
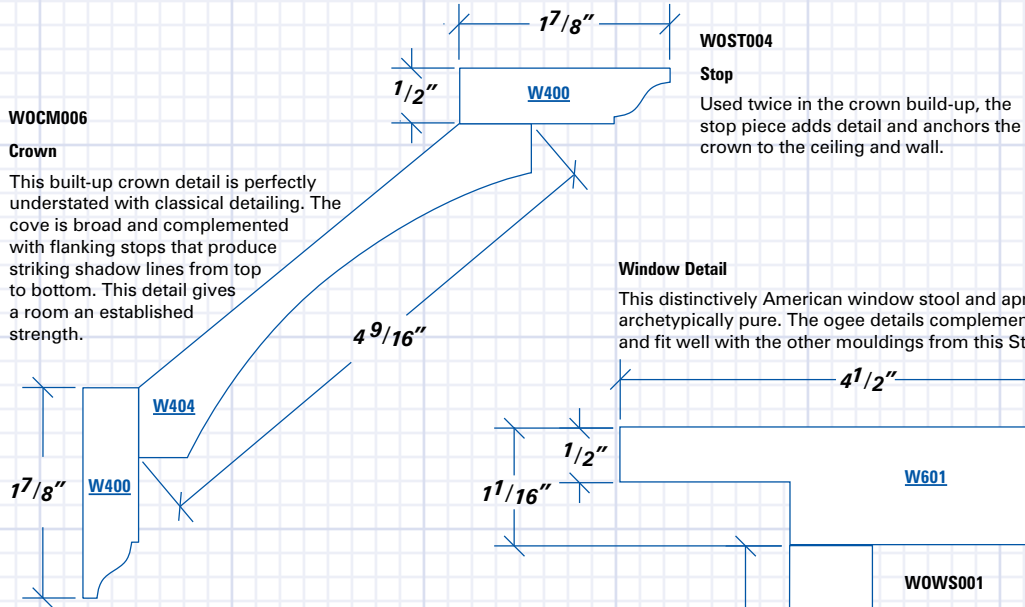

**1920-1940:** A celebration of the colonial era, this Style reflects new design interpretations of the classical order with smaller proportions and distinctive ogee detailing, characterized by the reversed curve on the base moulding, casing and picture moulding designs.

*\*images not shown to scale*

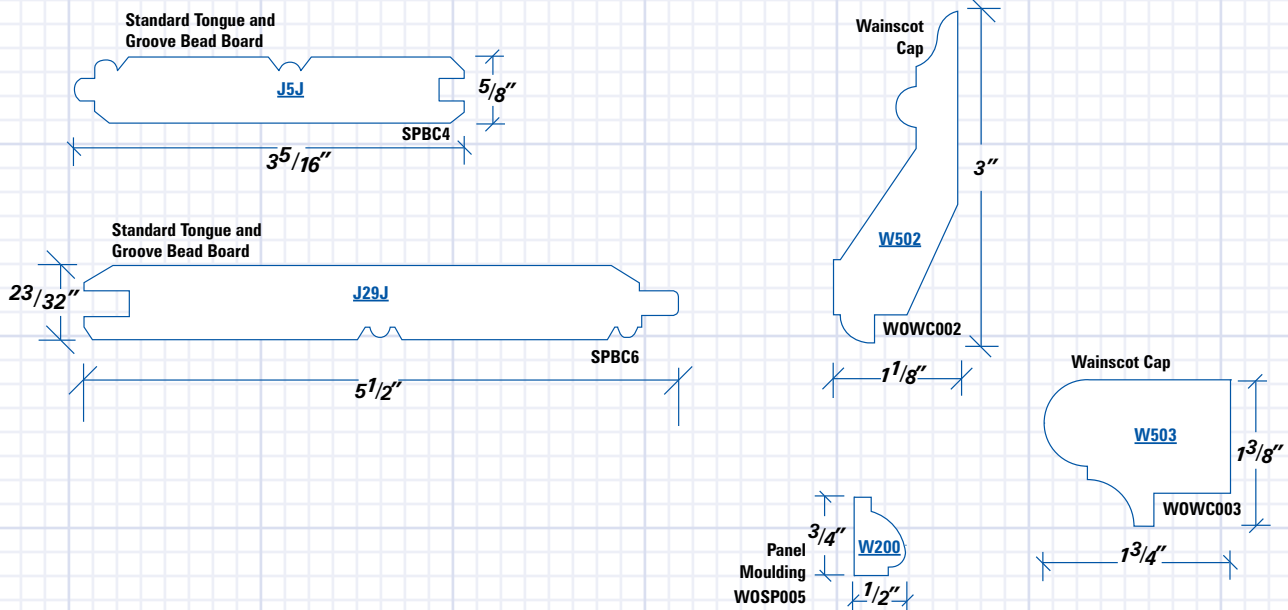
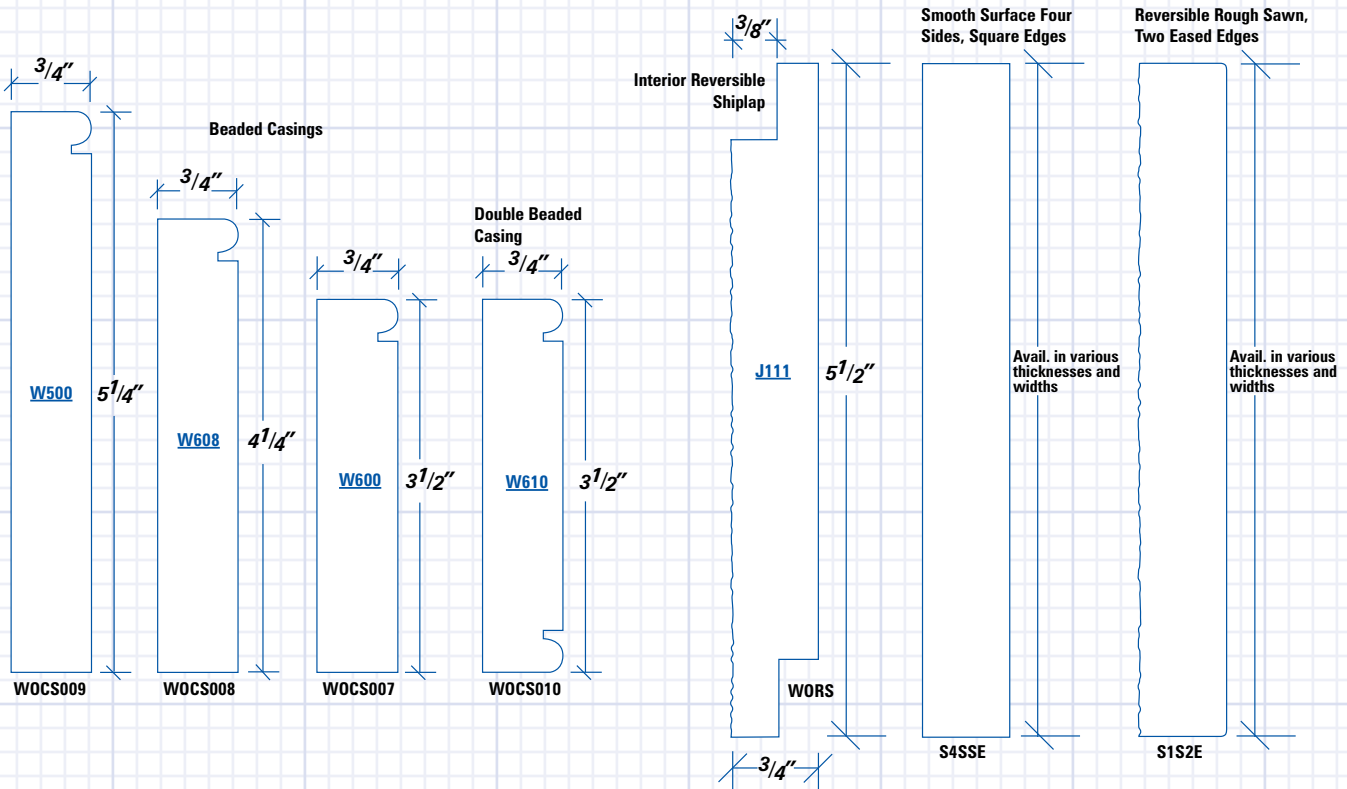

# Installation Tips

The following section is taken from Rob Thallons  
 "Graphic Guide to Interior Details," published by Taunton Press.

We have included this in our book because it represents the single best review of trim and moulding in print. We firmly believe that each project should begin with and be guided by these wonderful books and videos.

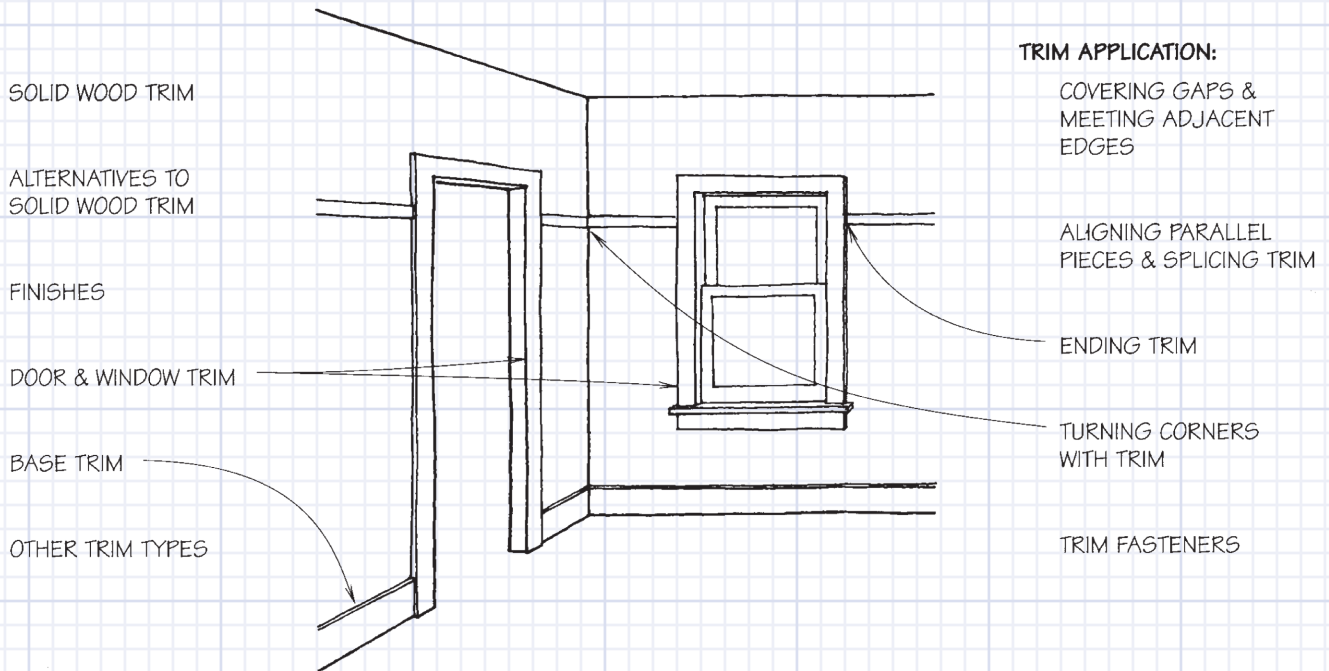

**T**rim, one of the very last things to be added to a building under construction, has the primary function of covering gaps between loosely fitting parts, such as between window and wall and between wall and floor.

Trim can also protect the building from abrasion where furniture or people are likely to bump into it. Baseboards, for example, protect walls from shoes, chairs and other things moving at the level of the floor, while door casings keep walls from being damaged as people and objects pass through the doorway.

Trim, called moulding when it is cut into specific shapes, also contributes significantly to the character of an interior space. There is an obvious difference between a door trimmed in the most minimal fashion and one trimmed with a full complement of ornate period mouldings.

Coordinating trim with the scale of a room, with the other surface materials and with the architectural features of a building is an important aspect of interior detailing.

Wood moulding was once made by hand with planes that held uniquely shaped blades. With the development of the moulding machine in the late 19th century, trim started to be mass-produced, and the use of intricately shaped pieces increased significantly. The earliest trim was made of the finest-grained wood available, both for its beauty and to facilitate manufacture and installation. Today, such fine-grained wood is scarce, so alternatives, including composite wood products and nonwood products, have been developed (see 152). Some of these alternatives are virtually indistinguishable from traditional wood molding when painted, but no modern alternative can match its predecessors when treated with a clear, natural finish.

This chapter describes primarily the principles and particular details that apply to solid wood mouldings. Most of these principles and details also apply to alternative mouldings made of MDF, and many apply to plastic mouldings.

# SOLID WOOD TRIM

## Trim Profiles

The simplest trim is made from unprofiled boards, rectangular in shape and milled to a smooth surface on all four sides. These boards are typically available in 1x2, 1x3, 1x4, 1x5, 1x6, 1x8, 1x10 and 1x12 sizes (nominally), depending on the species.

When boards are milled into more complex shapes with combinations of curved and straight surfaces, they are known as mouldings. Wood mouldings are characterized by their profiles, or cross-sectional shapes. Available profiles vary from region to region, but most can be milled from a 1-in. (nominal) board.

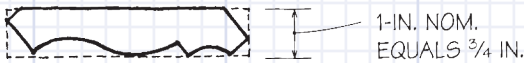

Many of the larger profiles have a relieved back designed to minimize cupping by reducing the thickness of the trim. The relieved back also allows the trim to span over irregularities in the wall and helps the installer fit the edges of the trim tight against the adjacent materials.

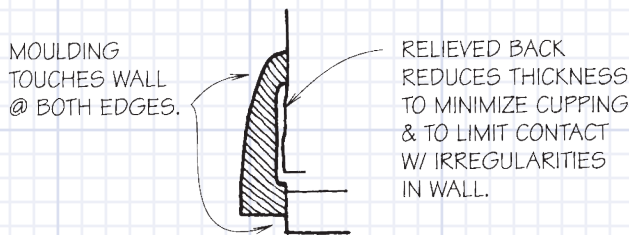

MOULDINGS W/ RELIEVED BACK

## Typical Species

Standard, off-the-shelf profiled wood moulding is made primarily of lengths of softwood—namely fir, pine or hemlock—and some hardwood, primarily oak and some white hardwoods such as alder, birch or poplar. Unprofiled boards are generally available in the same species as profiled mouldings.

Finger-jointed moulding made of inexpensive short lengths of clear softwood (usually pine) joined at the ends with interlocking, glued joints is also available in some profiles for trim that is to be painted (see 153B). Finger-jointed pine boards with a clear wood veneer are also available in some species for stain-grade trim.

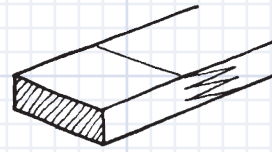

FINGER-JOINTED TRIM

## Moisture Content

Like all lumber products, wood trim changes dimensions with a change in moisture content (see 156). To minimize the effects of this, trim is dried to 7% to 10% moisture content, depending on the location of manufacture and time of year. As a precaution, however, trim should be stored inside at the (heated) job site for several days before installation.

## Custom Milling

Custom milling to achieve a special profile or to use an unusual species of wood is more expensive than using standard mouldings but is not uncommon. Special profiles may be milled from any species of wood, but when the trim is to be painted, species that have consistent grain and are easily machined, such as pine or poplar, are preferred. When the trim is to have a transparent finish, it is not uncommon to custom mill more unusual species such as mahogany, redwood, maple or katsura to showcase their features or to match cabinetry. Most trim carpenters mill some simple special-purpose mouldings on site with a table saw and/or router at little additional cost.

## Building Up Trim

Because elaborate trim profiles can be nearly impossible to make from a single piece of wood, complex profiles have traditionally been built up of several smaller pieces of standard trim. The smaller pieces are also more flexible so that they will conform to irregularities in the adjacent surfaces more readily than a single large piece. Since standard trim profiles are milled from less expensive small-dimension stock, building up trim is generally less expensive than custom milling a larger intricate moulding from a single piece.

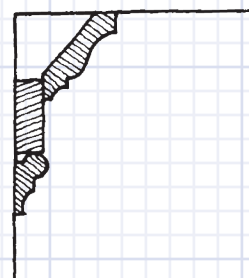

BUILT-UP TRIM



# MOULDING PROFILES

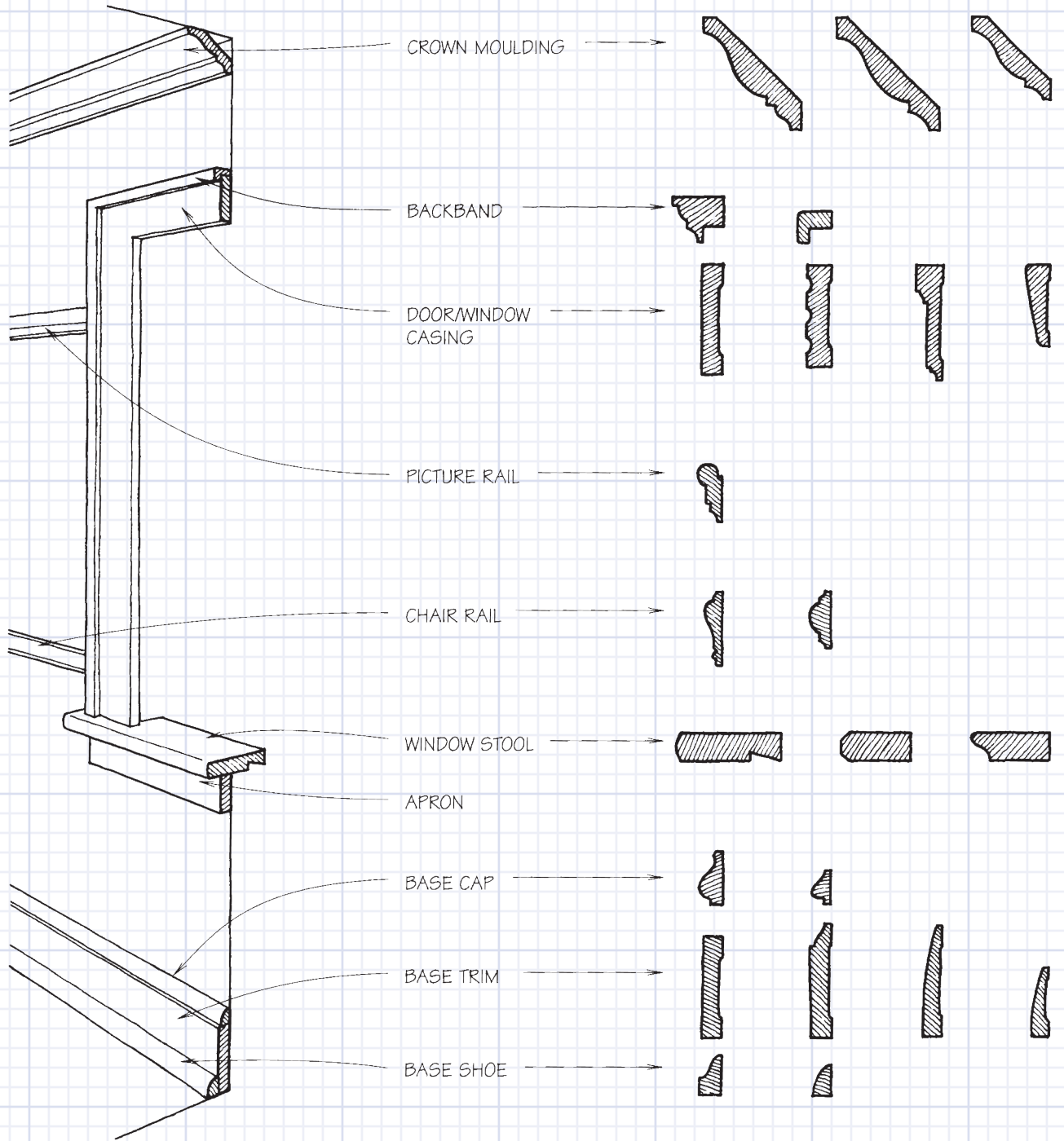

-   
 SPRUNG COVE
-   
 COVE
-   
 CORNER CAP
-   
 STOP
-   
 HALF-ROUND
-   
 QUARTER-ROUND

## ALTERNATIVES TO SOLID WOOD TRIM

There are several alternatives to solid wood trim that are appropriate if the work is to be painted. The choice of profiles tends to be somewhat more limited for these alternatives than for standard wood trim, but most material types have a sufficient selection of trim for all standard conditions.

### Medium-Density Fiberboard (MDF)

MDF is a dense, recombined wood product that is relatively inexpensive and is easily cut, sanded, shaped and attached to the building with normal woodworking tools (see Appendix B). For use as trim, MDF is available in sheets that can be custom cut and/or shaped at the site, precut rectangular sections (boards) and a limited number of shaped profiles similar to the common wood trim profiles.

Because of its appearance as a raw material, MDF trim is typically painted, and many premanufactured profiles are available primed. MDF used as trim has the drawback that changes in moisture content will affect the length of the pieces more than the same change would affect solid wood. Therefore, using it in buildings without air conditioning and in regions with significant seasonal humidity swings may not be appropriate. Given its low cost relative to other trim, its availability and its similarities to solid wood, however, MDF seems the most likely of the current alternatives to displace solid wood as the principal material for the painted trim market.

### Plastic Mouldings

Made of petroleum products, plastic trim has a density similar to pine. It can be cut, sanded, shaped and attached to the building with normal woodworking tools. However, plastic molding is more consistent than wood since it does not have the irregularities of grain. Plastic moulding also does not absorb moisture so is not subject to dimensional changes.

Plastic moulding is less expensive than hardwood moulding but more expensive than finger-jointed pine. Plastic is also not generally available in the same shapes as board, so built-up trims (see 150) must usually be combined with MDF or wood.

The most common plastic mouldings are made of fiber-reinforced polyester or extruded polystyrene. Both are available in standard profiles for typical trim tasks such as base, casing, chair rail and crown mould. They are typically manufactured with a primed coating or prefinished with an ersatz wood grain pattern. Plastic

corner blocks are available for virtually all conditions and thus allow the inexperienced homeowner to apply the moulding without having to make anything but square cuts.

A slightly more dense plastic moulding is made of polyurethane. Many profiles made of this material are modeled after traditional wood profiles. In addition, there are elaborate ornamental molded profiles with sculptural repeating forms that would originally have been made of cast plaster or of several built-up pieces of wood. Because the plastic material is dimensionally stable, these complex shapes can be and are often quite wide. Some patterns are also made in a flexible moulding that is able to conform to inside or outside curves with a radius as small as 2 ft., depending on the pattern.

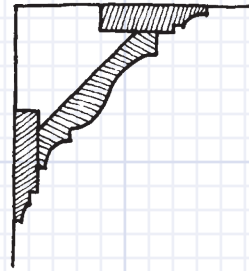

BUILT-UP WOOD CROWN  
MOULDING

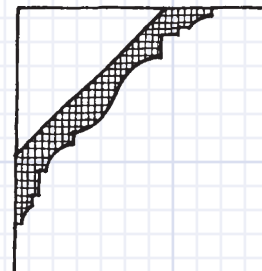

SINGLE-PIECE PLASTIC  
CROWN MOULDING

### Plaster Mouldings

Fiber-reinforced gypsum-plaster mouldings that are either extruded (drawn) or cast are available. Many of these mouldings are modeled after historic plaster castings that were used to make elaborate ceilings. Because they are relatively soft and brittle, the use of modern plaster mouldings is generally limited to ceilings and other areas of a building that do not receive abuse.

### Vinyl and Rubber Moulding

Vinyl and rubber moulding are thin (approximately 1/8 in. thick) and are manufactured in long rolls. The materials are supple and durable and are available in a variety of colors. Vinyl and rubber moulding are attached to the wall with adhesives rather than fasteners. Used extensively in commercial work, these materials are available only as base moulding.

## THE NO-TRIM ALTERNATIVE

@ WINDOWS & DOORS

One of the most common alternatives to using wood trim is to eliminate the trim altogether by using gypsum wallboard (GWB). With the aid of metal or plastic edge trim (see 9A), GWB makes a clean edge against the window or door. This economical approach is most commonly employed at windows or exterior doors where the GWB wraps the corner of the opening and dies into, or butts into, the window or door jamb, eliminating both jamb extender and wood trim.

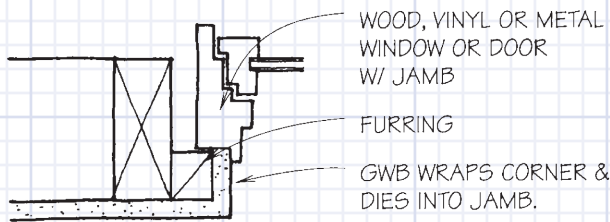
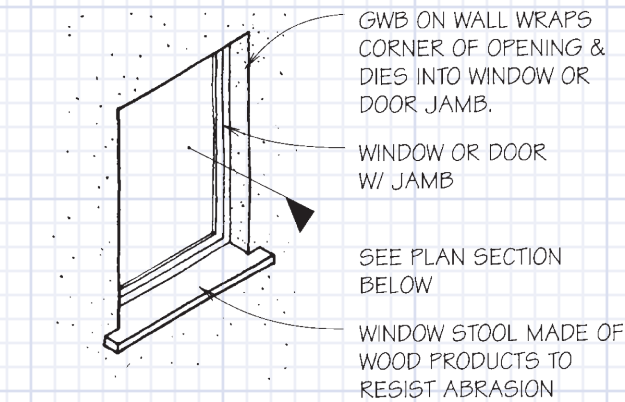

**PLAN SECTION**

When a wood jamb (or jamb extender) extends the full thickness of the wall, such as for an interior wood door, GWB may still be used in place of trim and may butt or lap the jamb.

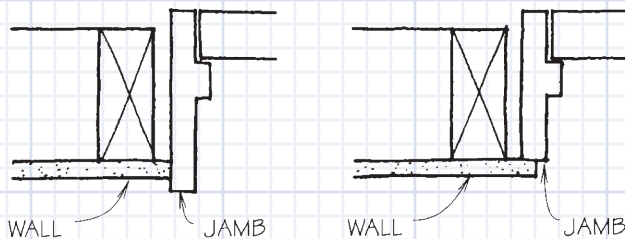

**GWB BUTTS JAMB**

**GWB LAPS JAMB**

## FINISHES

PAINT VS. STAIN

The decision of whether trim is to be painted with an opaque finish or to have a transparent natural finish such as a stain should be made before trim materials are selected. Each choice has cost implications and will make a significant impact on the appearance of the interior. Painted trim is generally more easily matched with other components of an interior space such as doors, windows and cabinets. However, stained wood can take abuse better than painted wood because a scratched or chipped surface does not show as much and dents tend to blend with and may even complement the exposed natural grain. Stained trim can also be changed to painted while the reverse is not true.

For painted work, the options for materials are considerably greater than for stained work since the trim will be coated with an opaque film. This means that low-cost mouldings made of finger-joined pine, MDF or plastic may be used. The cost of labor to install painted trim is also less than for stained work, since the painting (and caulking) cover a lack of refinement in the trim and its installation. Substantial gaps can be filled with a quality caulk that is applied with a caulk gun and smoothed with a wet finger. Fasteners used to attach the trim are also easily concealed when the work is painted. In fact, modern caulking and filling compounds that accept paint well are an important component of quality painted trim.

The savings realized in the cost of material and the installation of painted trim will likely be eroded somewhat by the application of the paint itself. A high-quality paint job generally requires three coats—a primer and two finish coats (with caulk applied between the primer and first finish coat). A stain job can normally be completed in two coats. Finishing painted trim is likely to cost about 50% more than finishing stained trim.

Trim that is finished with a stain or other transparent coating must be fastened to the finish wall more carefully than paint-grade trim. There are fewer choices for materials, and the material specified is usually an expensive clear grade of wood. In addition, the installation cost is greater since the cracks and gaps that can be easily filled with caulk in painted work are not acceptable for work intended for a clear finish. Even nail or staple holes (see 158), easily filled and concealed in paint-grade work, must in stain-grade trim be either strategically located or filled with material that is carefully color-matched to the wood.

## COVERING GAPS & MEETING ADJACENT SURFACES

Understanding the general principles of how trim is applied and how it performs under various conditions will help the designer select moldings and design details so that the entire assembly of trim in a room or building can be logical, durable and beautiful.

### Covering Gaps

Given that the primary objective of trim is to conceal gaps between the edges of adjacent materials, a simple overlapping of the trim onto the material is the most direct way to accomplish this task.

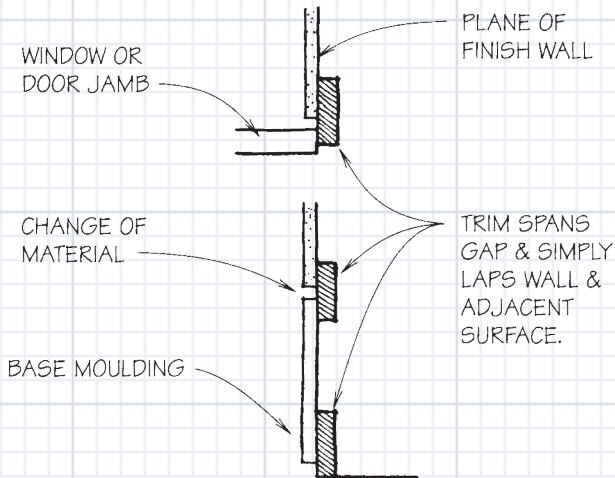

Most trim will be applied to the finished surface of an interior wall, so it is sensible to use this plane as a reference point.

### Meeting Adjacent Surfaces

The gaps between materials that must be covered by trim are, for the most part, quite long and are adjacent to materials that have less than perfectly regular surfaces. The use of a reasonably thin trim piece that will bend to conform to the irregularities of the adjacent surface is often required to make a tight joint.

When a single piece of trim is expected to bend in both directions to conform to irregularities, a moulding such as quarter-round that is thin in both directions works best.

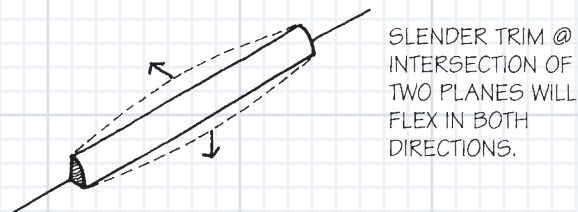

Sanitary moulding, a thin, inexpensive moulding with one curved corner, and other mouldings of similar size are usually sufficiently supple in both directions to achieve the desired fit.

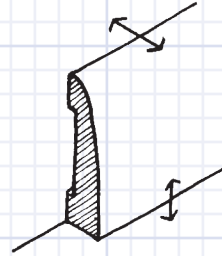

SANITARY MOULDING OR OTHER THIN BASE CONFORMS TO IRREGULARITIES IN WALL & FLOOR.

When a wider moulding, such as a tall baseboard, is specified, it must often be accompanied by a smaller piece such as a base shoe or base cap that will bend to conform to the irregularities of the floor.

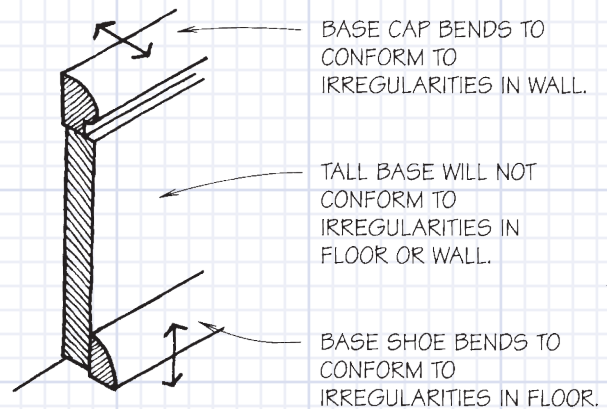

BASE CAP BENDS TO CONFORM TO IRREGULARITIES IN WALL.

TALL BASE WILL NOT CONFORM TO IRREGULARITIES IN FLOOR OR WALL.

BASE SHOE BENDS TO CONFORM TO IRREGULARITIES IN FLOOR.

If wide mouldings are desired without having to build up with thin pieces that bend, a single-piece wide moulding can be scribed to the material it trims. Scribing involves planing the edge of the moulding so that it conforms to the contours of the material adjacent to it. The labor of scribing can sometimes be more expensive than the addition of a thin trim piece such as that discussed above.

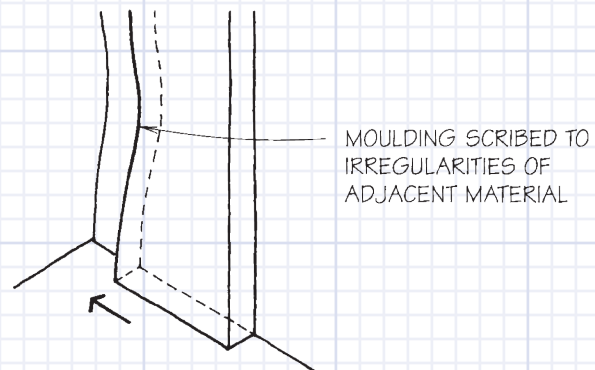

MOULDING SCRIBED TO IRREGULARITIES OF ADJACENT MATERIAL.

## ALIGNING PARALLEL PIECES

### Aligning Parallel Pieces

The perfect alignment of trim edges to the edges of window or door jambs or to other moulding is very difficult. This is because the existing window and door edges are rarely perfect, and the internal strength of the trim pieces makes them difficult to bend.

It is most common and practical to offset the two edges to create a reveal. The reveal makes a shadow line that for all practical purposes aligns the two edges without having to make the alignment perfect. Slight variations in alignment will not be perceptible because of the offset between the two edges. The reveal is used extensively in trim detailing.

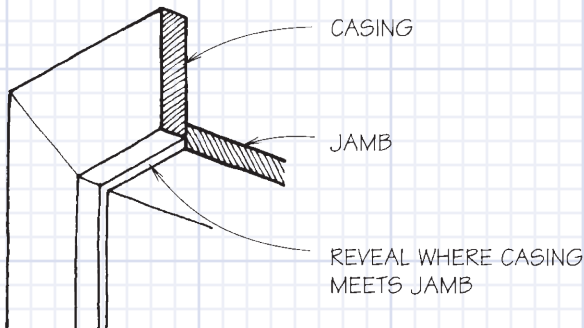

When it is necessary to align a piece of trim flush with another material, the trim may first be glued and nailed to hold it in place. The joint can then be planed and sanded smooth to make the edges perfectly flush. The nail or screw holes can be filled and the surface painted. For stained or clear finish trim, the exposed fasteners may be eliminated with a spline or biscuit joint that locks the pieces together internally like a tongue-and-groove detail.

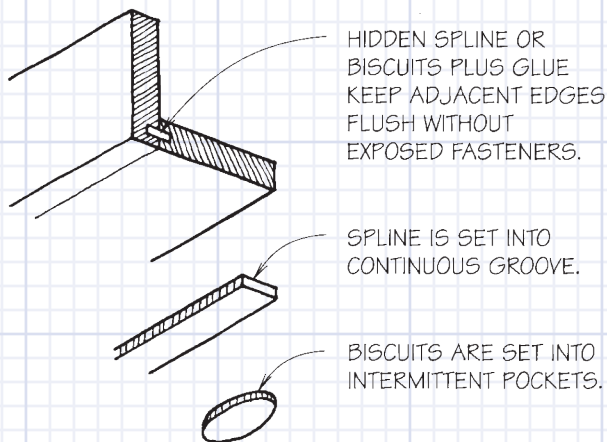

## SPLICING TRIM

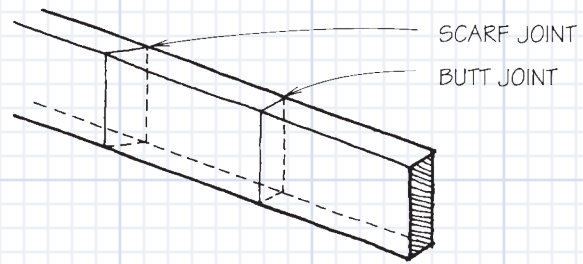

Trim must be spliced if a single piece cannot be found to extend the full length of a long wall. The scarf joint, which joins the ends of trim with a sloping lap-joint, has traditionally been considered the best detail for this situation, especially for stain-grade trim.

Any slight change in the length of the trim will slide the lapped pieces across one another but will not cause a crack in the joint. The scarf joint is not used as much today because it is slow and troublesome compared to the simple butt joint. The butt joint may be considered as good a joint as the scarf joint, especially for painted work, which will show a crack in the paint if the trim moves, whatever the joint used.

## WRAPPING COLUMNS & BEAMS

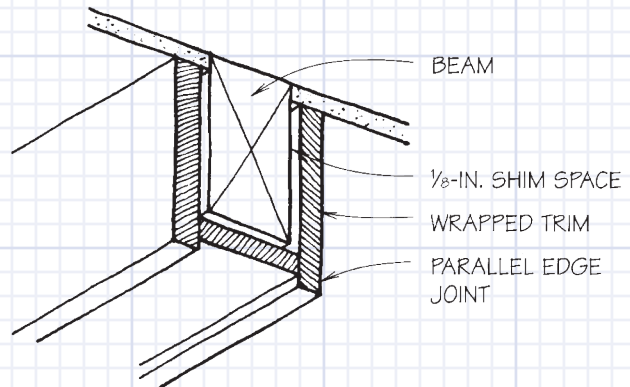

Structural members such as columns and beams are frequently wrapped (or boxed) with finish material to improve their appearance. Wrapping can be accomplished with virtually any material, but it is most frequently done with gypsum wallboard or wood trim, as shown above.

A 1/8-in. shim space is required between structure and finish because the structural member can be expected to be irregular, and this space will usually be sufficient to span the irregularities of the member.

# TURNING CORNERS WITH TRIM

It is very common for trim to turn a corner. The corner can be an inside corner, an outside corner or a flat corner. Following are the basic joints that can be employed to make these corners:

**Miter joint**—The miter joint is common because of its versatility. The two pieces of trim that make a corner are cut at 45°, which allows moldings of any profile to make corners of any type.

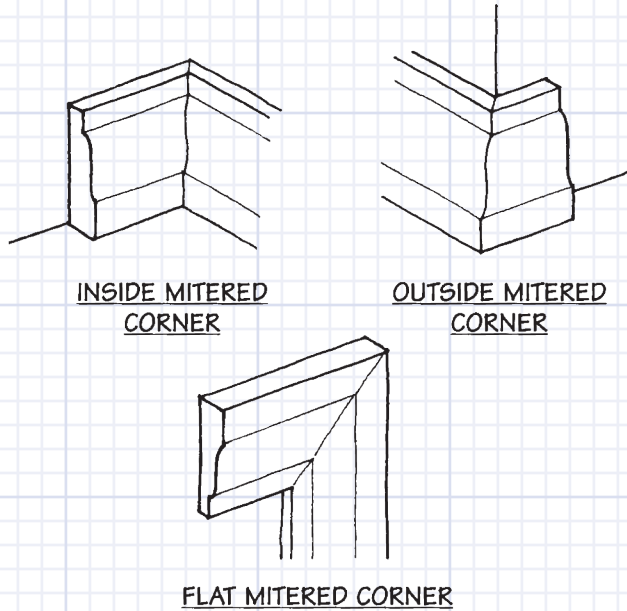

The only disadvantage of the miter joint is that dimensional changes across the width of the trim caused by variations in moisture content can create a gap at the miter. This phenomenon is especially likely to occur with wider or thicker moulding pieces but is often disregarded when choosing them.

**Butt joint**—The simplest of corner joints, the butt joint is useful only for simple trim pieces of rectangular section. Common for inside or flat corners, the butt joint at the flat corner has the disadvantage of showing end grain, which does not paint or stain well.

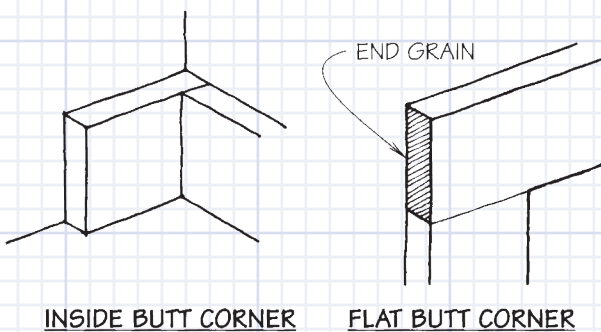

**Coped joint**—The coped joint is superior to the mitered joint for profiled moulding at inside corners. This joint is made by cutting (coping) the end of the second moulding piece to match the profile of the piece applied first. The coped cut incorporates a backcut so that only the exposed edge of the coped piece touches the first piece of moulding. When the second piece is pushed up against the first, a tight joint that is unlikely to open with changes in the wood's moisture content is made. If a gap does appear, it will be consistent at all points.

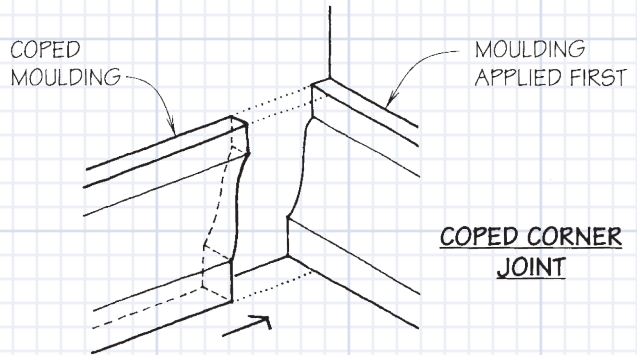

**Block joint**—The block joint is a simple, versatile joint that, like the miter joint, allows trim of any profile to make corners of any type. The pieces of trim butt against a thick block (called a plinth block when at the base of door trim—see 163A) to create a reveal. The disadvantage of the joint is that the block requires its own means of attachment.

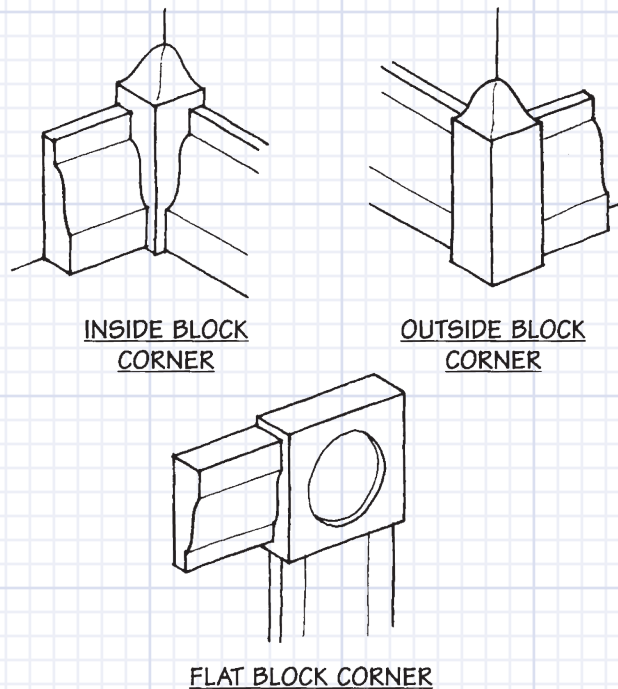

# ENDING TRIM

Each piece of trim must end somehow. If it does not turn a corner, it can either die into another material, such as a floor or another piece of trim, or it can simply stop. Knowing a few principles about conditions at the end of a piece of trim is useful in designing an overall trim package.

### Trim Dies into Another Material

One of the simplest ways for a piece of trim to end is for it to die (butt) into the surface of another material that is perpendicular to its length. This condition has the effect of capping the end of the trim piece with the surface into which it dies. Nothing further need be added to the assembly to make it appear finished.

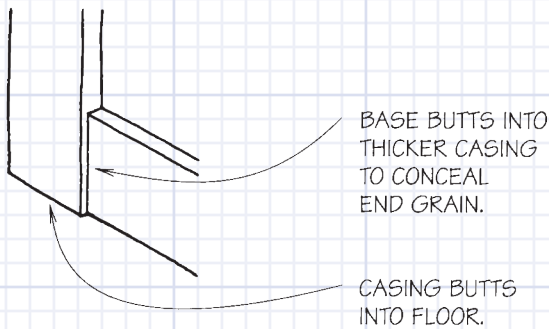

### Trim Terminates

Occasionally, it is desirable or necessary to end a piece of trim without butting against another material or turning a corner. This condition frequently occurs at window and door trim.

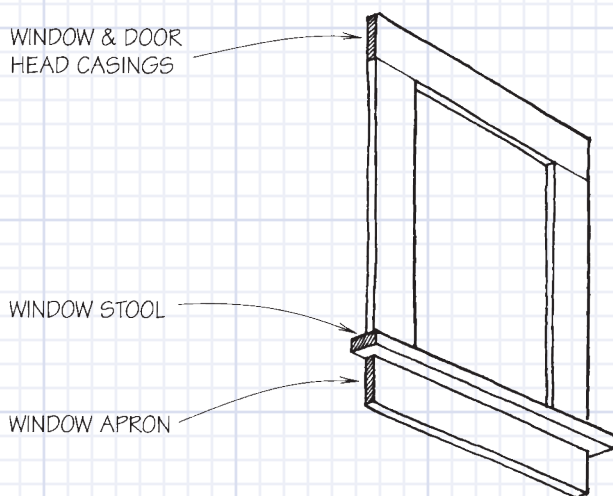

There are three basic approaches that can be taken to terminate trim:

**Square-cut**—The trim can simply be square-cut to length and left with the end grain exposed. This works fine in many cases, especially if the trim has a simple profile or is a simple board. The square-cut detail has the disadvantages that the end grain does not paint or stain well and that trim profiles with relieved backs will show the gap at the back of the piece.

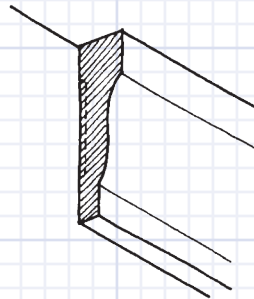

SQUARE-CUT TRIM SHOWS END GRAIN & RELIEVED BACK.

**Coped**—Mouldings with shaped profiles can be coped so that the end of the moulding matches the cross-sectional profile. This detail has the same disadvantages as the square-cut detail described above.

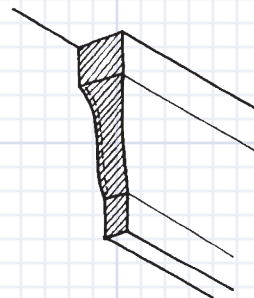

COPEd TRIM MATCHES FACE PROFILE BUT SHOWS END GRAIN & RELIEVED BACK.

**Mitered & returned**—Trim can be mitered and returned to the wall (or other surface) with a small piece of the same trim glued in place. This approach, although somewhat more involved, has the advantages of eliminating the end grain while also ending the moulding with the same profile as its cross section.

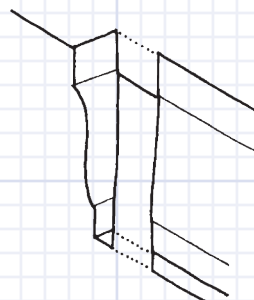

MITERED & RETURNED TRIM MATCHES FACE PROFILE, HIDES END GRAIN & HIDES RELIEVED BACK.

# TRIM FASTENERS

## Pneumatic Nailers

Until the advent of the pneumatic nailers (air guns) in the 1970s, virtually all trim was fastened by hand with finish nails. Finish nails, which have very small heads, are driven to the surface of the wood trim with a finish hammer and then below the surface with a few hammer blows to a nail set. This method is still used, but trim applied by professionals is now almost always fastened with pneumatic equipment.

The advantages of the pneumatic nailer are so numerous and compelling that it is almost impossible for finish carpenters to compete for work without one. Primary among these advantages is the speed with which the fastener is set to its finished position. This operation takes only a fraction of the time taken to drive and set a finish nail by hand. The operation also takes only one hand, freeing the other hand to hold the trim accurately in place. Finally, the single blow with which the air gun sets the nail below the surface also applies force to the trim piece, which tends to make the trim fit tighter to the wall than it would with the multiple blows of a hammer. This single pneumatic blow is sharp and crisp and allows some pieces to be joined that could not be easily joined with a hammer.

An air gun can also be used with staples. If both the nail and the staple are sized to have sufficient holding power for the materials on which they are used, the main difference between the two is the shape of the hole that they leave on the surface of the trim.

 FINISH NAIL HOLE

 FINISH STAPLE HOLE

For painted work, the shape of the holes to be filled makes little difference because a good painter can make them disappear even to the critical eye. For clear-finished work, however, the fastener holes can be seen through the transparent finish and can detract from the overall appearance. Staple holes have the advantage of being long and thin so that, if oriented in the direction of the grain, can blend better with the natural surface of stained woods.

## Screws

In addition to nails and staples, screws are sometimes used to attach trim. Trim-head screws are used to attach trim to steel studs. They are also advantageous for locations that require more holding power than a nail or staple can deliver. Trim-head screws have heads only slightly larger than the heads on pneumatically driven finish nails and are installed with a square driver. The screws are self-tapping, and some will create their own pilot holes in light steel framing as they are being installed. This type of fastener tends to split solid wood trim, especially hardwood, so predrilling of moulding may be recommended.

## Adhesives

Adhesives are used, usually in conjunction with other fasteners, to increase the bond between trim and the material to which it is fastened. Adhesives are especially useful where two pieces of trim must remain flush (see 155). Adhesives are also sometimes used by themselves for very small pieces of trim that would probably be split by a nail or staple.

## Filling Fastener Holes

Filling holes in trim that is to be painted is reasonably straightforward. There are many fillers available that can be matched to the materials, applied, sanded and covered with paint. For stained trim, however, the job of filling holes is much more critical because the filled hole will remain visible after the trim is finished. Matching the color of the wood is the most difficult part of filling stained work. The darker the stain, the less critical this task becomes, whereas for very light stains or clear finishes, the color of the wood must be matched almost exactly for the fastener holes to disappear into the finished work. Over time, clear finished wood usually changes color, so that even though the filler color matches the wood at the time of installation, it probably will not match the finished trim in a year or two.

Premixed fillers with colors supposedly matched to specific species are available, but they rarely match exactly because of the variety within each species and, in some cases, within a single piece of trim. These premixed fillers are often adequate for dark stained work, however. The best way to match trim color with filler is to custom-mix the filler at the site with the aid of a palette of colors. This is done for the best clear finish work, often after the trim has been finished and has had a year or more to change color.



# DOOR & WINDOW TRIM

## JAMBS, STOOLS & APRONS

Doors and windows have basic functional components, as shown below (door components are like windows except that a door replaces the window sash and doesn't have a stool or apron).

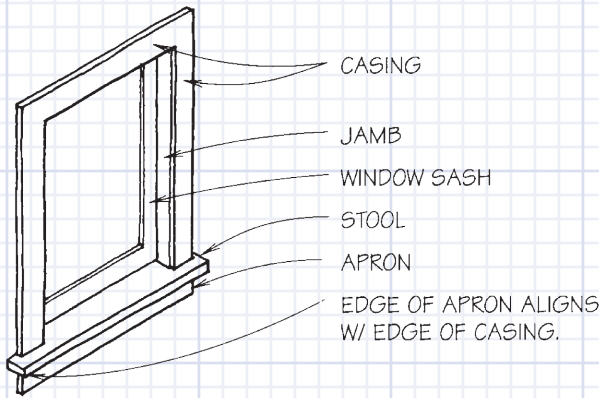

### Jambs

Key among door and window components is the jamb. The side jambs and the head jamb (often simply called the head) of a window or door hold the operational elements—the door or the window sash—in place. The edge of the jamb is lapped by trim, called casing (see 160–61), which spans the gap between jamb and finish wall. Windows today are provided with a range of trim packages from which to choose. It is also possible to select trim casings, stools and aprons separately.

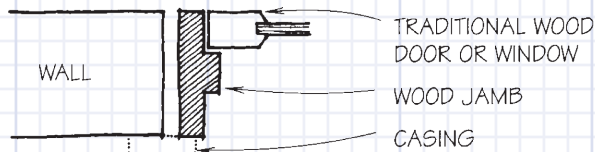

Some jambs are made the same way today as they have been for centuries. For example, interior door jambs are usually made of a single piece of wood that extends the full thickness of the wall and has trim on both sides of the wall lapping the jamb.

**Jamb extenders**—Most modern wood windows and exterior doors have jambs that do not extend through walls that are framed with materials thicker than 2x4s. To trim these windows and doors with wood, extenders must be added to the jamb. Modern metal

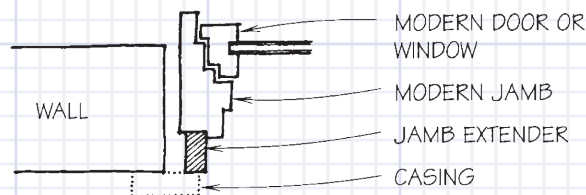

and vinyl windows require wood jamb extenders if wood casing is to be used.

### Stools & Aprons

Wood windows traditionally have been trimmed inside with a wood stool and apron as a complement to the exterior sloped sill. The stool protects against water penetration at its outer edge and provides a wide level surface inside. A trim piece called an apron covers the gap between stool and finish wall surface. The simplest apron can be an unprofiled board. Elaborate aprons may be built up of several pieces.

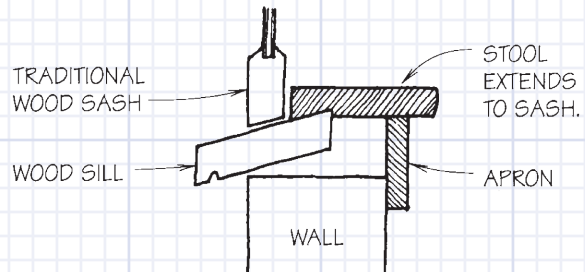

The sill of a modern window is not sloped but is usually the same as the side and head jambs. And instead of a stool, these windows are often trimmed at the bottom with a jamb extender and casing that are identical to the jamb extenders and casing on the rest of the window, thus making picture-frame casing.

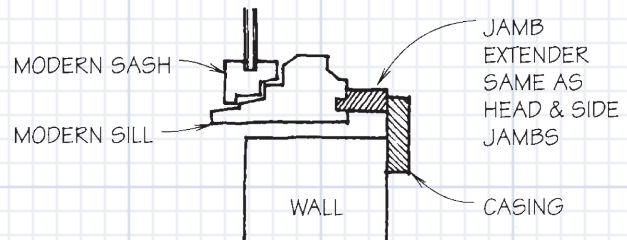

Alternatively, a shallow stool with an apron may trim the modern window base. This detail provides a wider surface and allows a variety of casing types to be used (see 160-61). A stool and apron can also be used when there is no head or side casing and gypsum wallboard wraps the corner and butts the jamb.

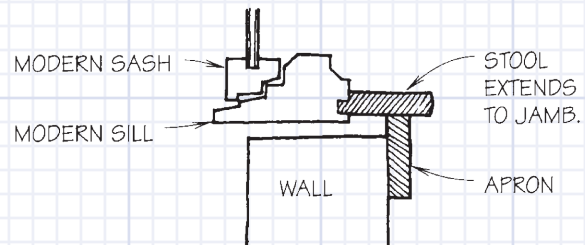

## DOOR & WINDOW CASING

### JOINT TYPES

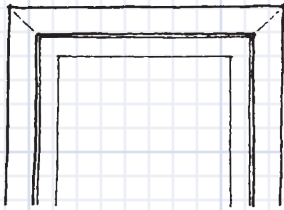

MITERED JOINT

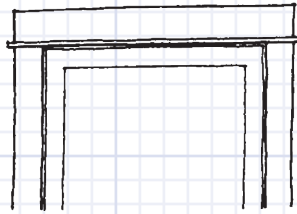

BEAD JOINT

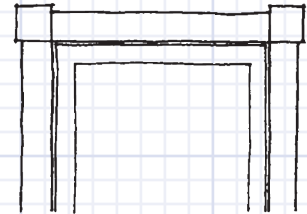

CORNER BLOCKS

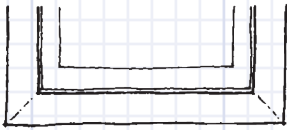

A MITERED JOINT IS OFTEN USED @ BASE OF WINDOW WITHOUT STOOL. THIS IS CALLED PICTURE-FRAME CASING.

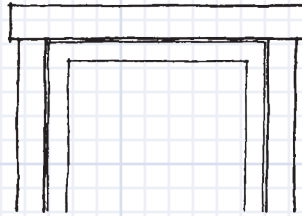

REVEAL JOINT

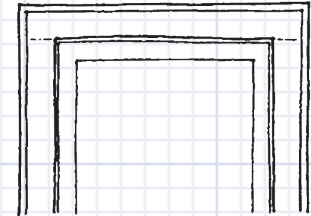

BUTT JOINT

## DOOR & WINDOW CASING

### DESIGN STRATEGIES

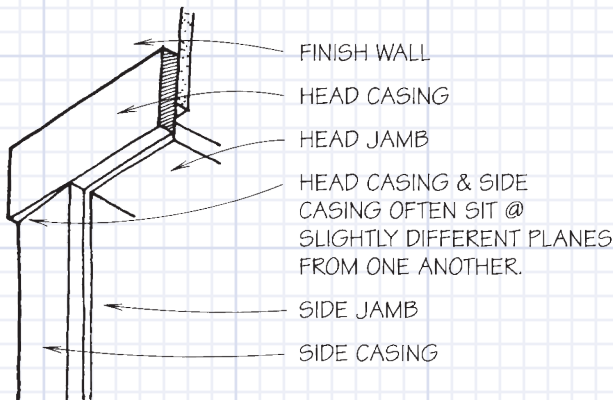

The gap between the jamb or jamb extender and the wall is covered with trim that is called casing. There are several types of window and door casing, and they are differentiated primarily by the way the head and side casing meet. Because casings straddle the gap between the jamb and the often irregular surfaces of the wall, the head casing and side casing often sit at slightly different planes from each other. Most of the corner joints have therefore been developed to provide a reveal, allowing the unavoidable slight misalignment to go unperceived.

## MITERED JOINT

### @ DOOR & WINDOW CASING

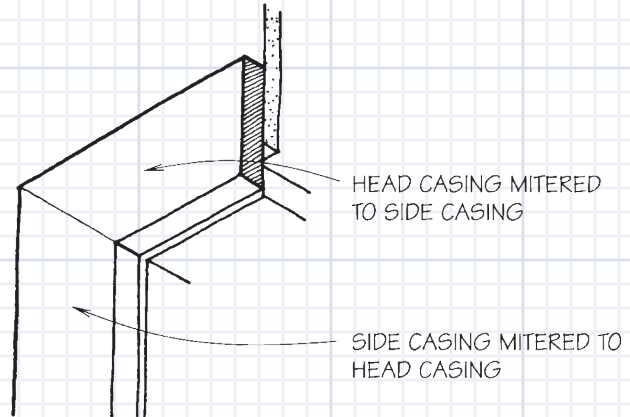

One of the most common corner joints, the mitered joint has the advantage of simplicity, but it does not make a reveal, so misaligned casings will be perceptible. In addition, the joint is useful only for narrow (3 in. or less) casings; dimensional changes across wider mouldings will open the joint. When a jamb extender is used in place of a stool, the miter joint is usually used at the bottom corners to allow the casing to wrap around the base of the window. This trim arrangement is commonly called picture-frame casing.

## BEAD JOINT

@ DOOR & WINDOW CASING

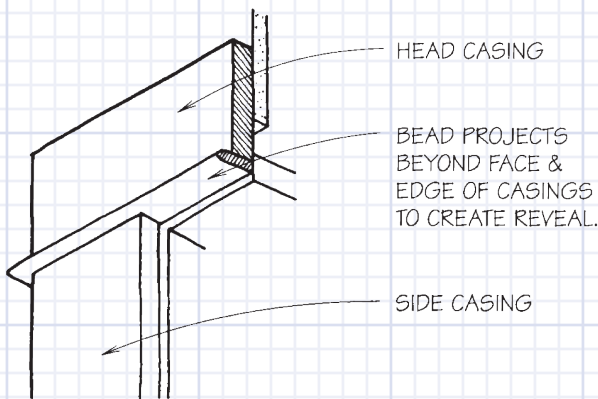

The insertion of a thin but extra-deep trim piece—a bead—below the head casing creates a reveal that allows a slight misalignment between side and head casings. Another advantage of this treatment is that if the head jamb is recessed from the wall plane the bead can be trimmed at its ends so that the central portion of the bead can rest firmly against the head jamb. The joint was popularized in Victorian buildings.

## CORNER-BLOCK JOINT

@ DOOR & WINDOW CASING

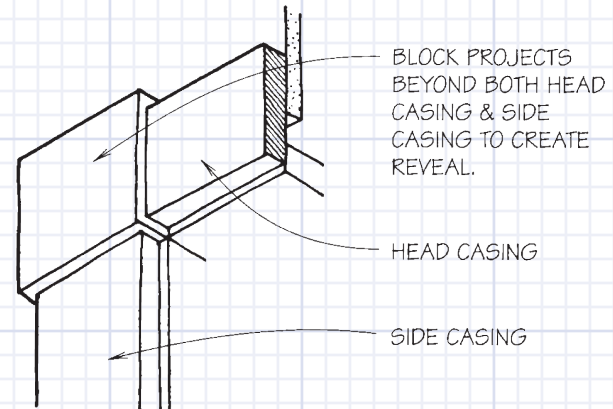

Inserting at the corners blocks that are thicker than the casings creates a reveal that allows both side and head casings to assume a slightly different plane from that of the wall. Popular in Victorian buildings, the joint was also used at the base of door casing where the casing meets the base trim.

## REVEAL JOINT

@ DOOR & WINDOW CASING

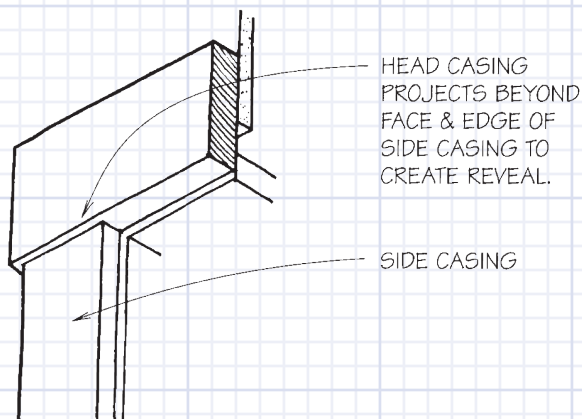

Similar to the bead joint, the reveal joint allows the side casings to be slightly misaligned from the plane of the wall. The reveal itself is created by using a head casing thicker than the side casings. A disadvantage of this system compared to the bead joint is that a jamb behind the plane of the wall cannot be so easily accommodated. The reveal joint came into common usage during the Craftsman period in the early 1900s.

## BUTT JOINT

@ DOOR & WINDOW CASING

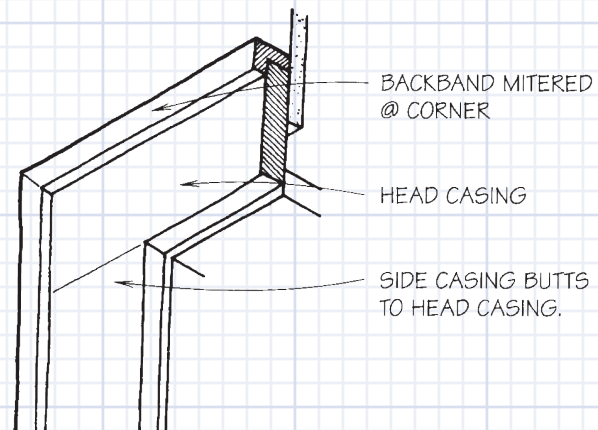

Simplest of all casing joints, the butt joint works only for square-edged casings of identical thickness and does not allow misaligned casings. The butt joint is often used in conjunction with a backband that covers the end grain of the head casing. The backband also adds visual complexity to the casing and can provide a reveal for base or other mouldings that may die into the casing.

## BASE TRIM

The transition between wall and floor is usually trimmed with a base moulding designed to form a neat edge against both surfaces.

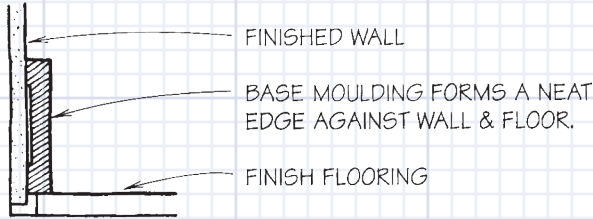

Base trim not only covers the gap between wall and floor but can also protect the wall from marks caused by shoes and furniture. Residences usually have a wood base moulding, while commercial buildings often employ a vinyl or rubber base trim.

Base trim in wood and other materials is available in many profiles. Base trims tend to have a slender or sloped top edge to ease the task of installing them against an uneven wall and to minimize places for dust to accumulate.

The finish materials of the walls and the floor are important to consider when selecting base mouldings. Carpet, for example, has different requirements for meeting a base trim than does wood flooring.

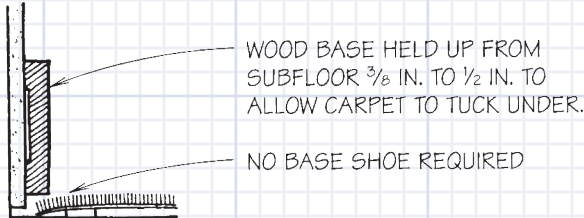

### Wood Base Trim

Wood base is available not only in a number of profiles but also in many different sizes. Smaller profiles such as sanitary base or quarter round are common because they are narrow enough to conform to irregularities in both wall and floor (see 154) and therefore can be applied as a single piece (drawing top right). Taller bases may be built up of several pieces and usually require a base shoe to conform to flooring contours (drawing middle right). An independent base cap may also be required to conform to irregularities in the wall.

One variation of the standard wood base is the flush base moulding, which looks simple but which can be expensive to install because of the required blocking and edge detailing of wall material (drawing bottom right).

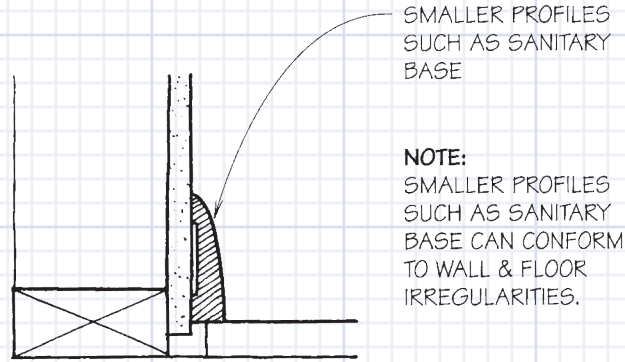

**SMALL BASE**

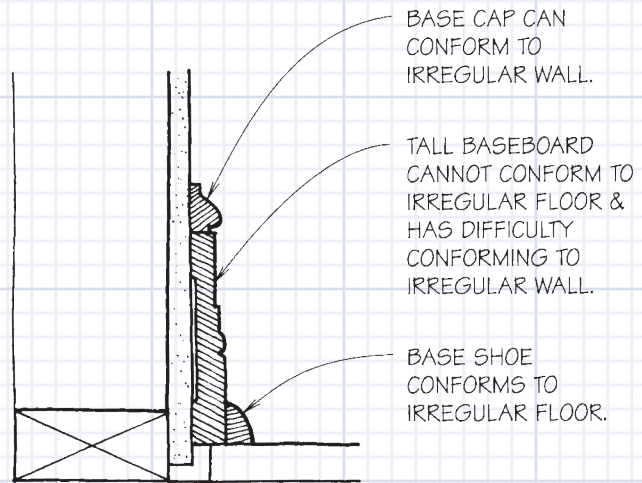

**TALL BASE W/ BASE SHOE**

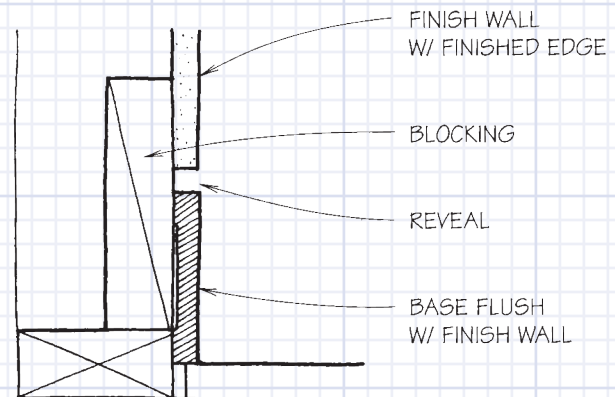

**FLUSH BASE**

## BASE TRIM @ DOOR CASING

Base moulding is typically applied to the surface of the finish wall, and it butts into the edge of the door casing. Coordination of base moulding with door casing should ensure that the face of the base moulding does not project beyond the door casing. Although the base and door trims shown below have rectangular profiles, mouldings of other profiles may be used.

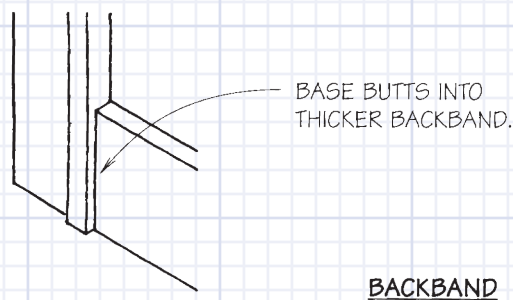
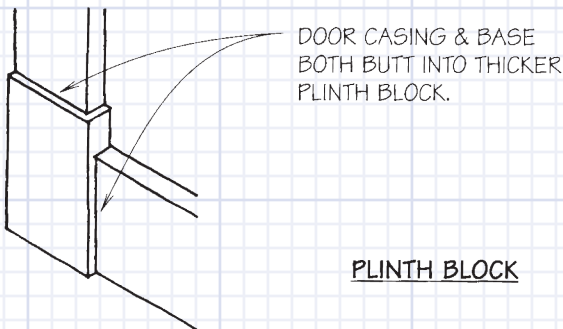
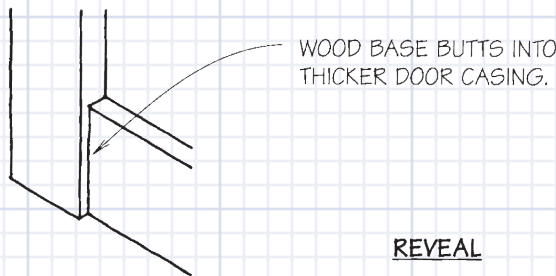
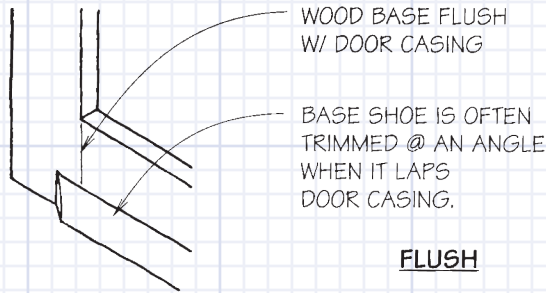

## VINYL OR RUBBER BASE MouldING

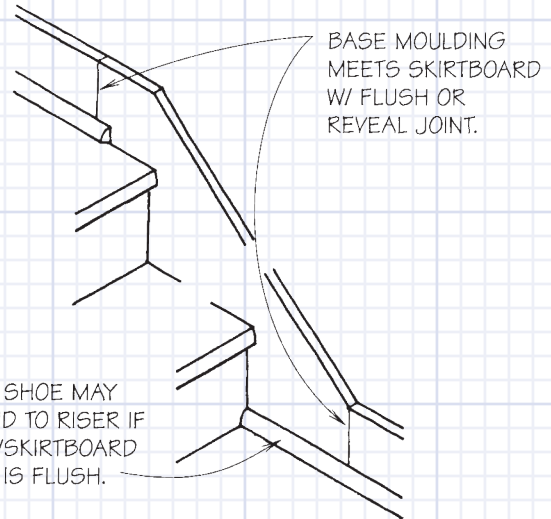

To make a neat connection between base trim and a stair skirtboard, the base trim should match the thickness of the skirtboard. The base shoe will then continue over the flush joint to the first riser. If the skirtboard is thicker than the baseboard, the baseboard can meet the skirtboard with a reveal joint but a base shoe (if any) will not continue to the stair riser.

## BASE TRIM @ STAIR

Common in commercial work, vinyl or rubber base moulding is inexpensive, available in a number of colors and easily applied with adhesive. It easily conforms to wall and floor irregularities. Standard heights are 2½ in., 4 in. and 6 in. Three typical profiles (shown below) can be matched with specific flooring types.

Manufactured outside corners are commonly used, but inside corners are usually coped. Vinyl and rubber base mouldings are narrow enough to die into door casings.

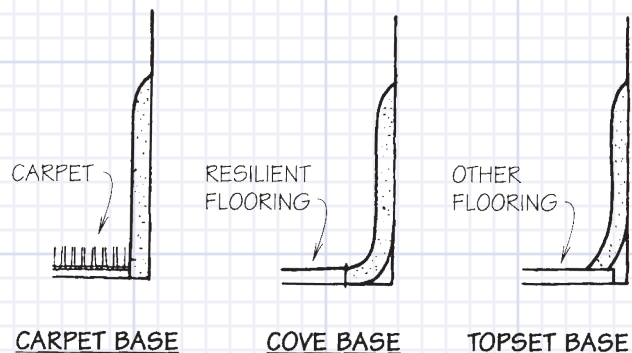

## SPECIALIZED MOULDINGS

### INTRODUCTION

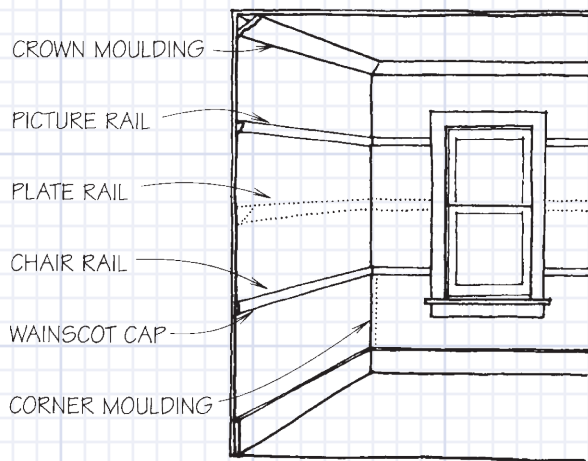

There are several specialized types of traditional mouldings that can be used functionally and decoratively. Many of these mouldings are applied continuously around a room and often require backing or blocking, so it is important to plan for such mouldings before wall finishes are in place.

Some of these mouldings (especially plate rails, chair rails and wainscot caps) commonly terminate at door or window casings. If the moulding is thinner than the casing, it can simply butt into the casing, leaving a reveal (see 163A). If the moulding is thicker than the casing, however, it must be terminated independently of the edge of the casing. This is commonly done with a coped or mitered end (see below and 157). An alternative is to add a backband to the casing and butt the moulding to the backband.

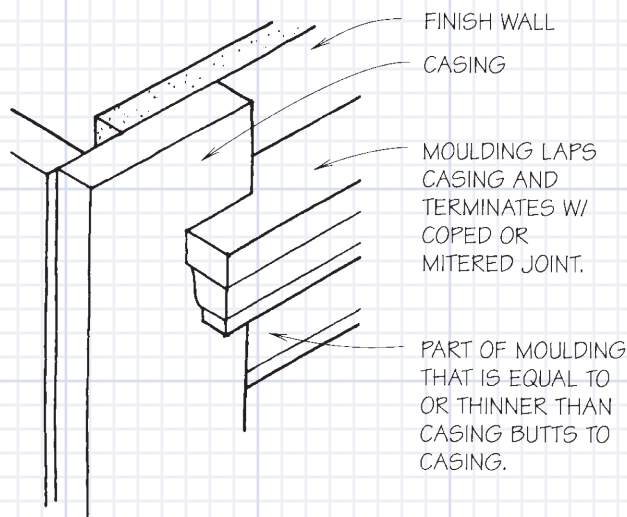

## CROWN MOULDING

Located at the intersection of a wall and ceiling, the crown (or sprung cove) moulding makes a transition between these two planes. Crown moulding typically circumscribes a room and is fastened to both wall and ceiling, so some blocking in the ceiling is usually required. Crown moulding can be built up of several pieces to be quite elaborate. Crown moulding can also be made with plaster.

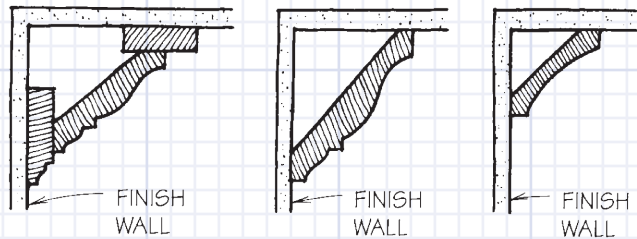

**BUILT-UP CROWN MOULDING**

**CROWN MOULDING**

**SPRUNG COVE**

## PICTURE RAIL

Historically, the picture rail has been used as a continuous strip around a room from which to hang pictures. Although the picture rail is not always used for hanging pictures today, its use has persisted because it provides a trim high on the wall that acts as an accent strip or a logical place to change paint colors. The picture rail is usually set either just below the heads of doors and windows where it dies into the side casings or just below the ceiling plane where it can flow around the room without interfering with other trim.

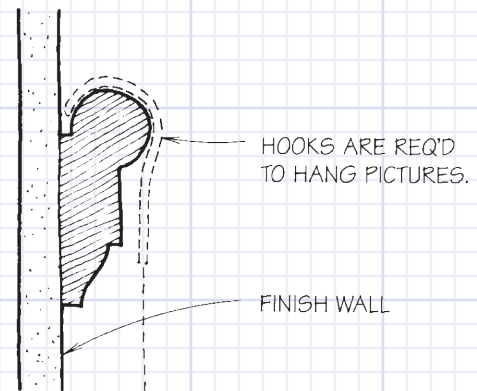

## PLATE RAIL

The plate rail was developed to display plates and other objects approximately at eye level. It is usually built up of several pieces of moulding and was used frequently in Craftsman-style houses. The plate rail is not common today.

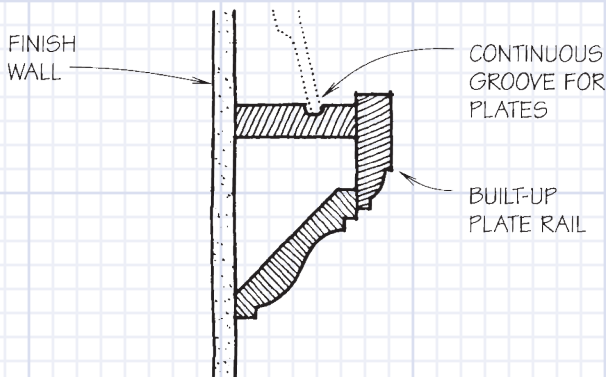

**NOTE:**  
AN ALTERNATIVE IS TO SUPPORT A CONTINUOUS SHELF WITH INDIVIDUAL BRACKETS.

## CHAIR RAIL

A horizontal moulding set about 3 ft. above the floor, a chair rail has historically performed two functions. First, it protected the relatively soft plaster surface of the wall from abrasion by chairs placed against it. Second, some types of chair rail were fitted with pegs on which chairs were hung while the floor was swept. The modern chair rail rarely has pegs, but rather acts as a visual divider of the height of the wall. The wall surface below the chair rail is often finished differently from the wall above, making the chair rail effectively into an inexpensive wainscot cap.

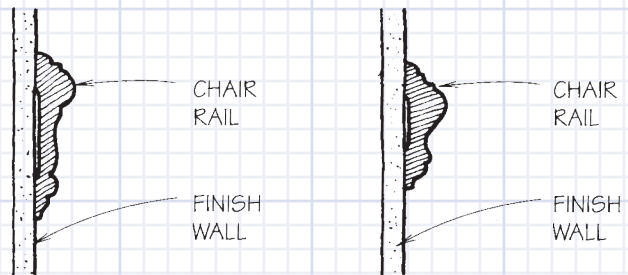

## WAINSCOT CAP

The wainscot cap covers the gap between the top of the wainscot (see 40-41) and the wall above. If the wainscot is flush with the wall, the wainscot cap can be very simple and, indeed, identical to a chair rail (see 165B). If the wainscot is applied to the surface of the wall, the cap must accommodate the difference between the planes of the wainscot and the wall above. In this case, the wainscot cap frequently builds out beyond the door (or window) casing and is detailed to lap the casing.

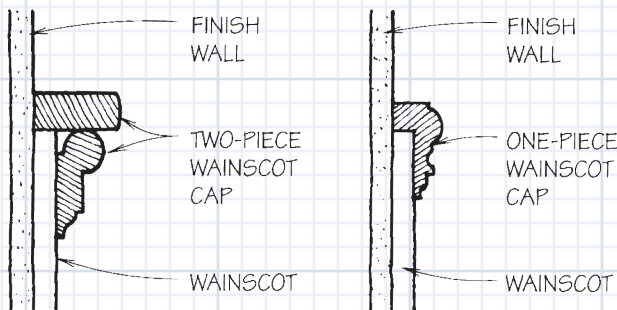

## CORNER MOULDINGS

Several mouldings are available primarily to trim corners.

**Corner cap**—The corner cap is designed to trim outside corners with a single piece of moulding. It is generally used in a vertical application, such as where the board paneling on two walls meet. The thin profile of the corner cap allows it to butt to other mouldings leaving a reveal.

**Cove**—Cove moulding is commonly used to trim inside corners and in combination with other mouldings to make built-up profiles.

**Quarter-round**—Like cove moulding, quarter-round moulding is used to trim inside corners. Quarter-round is also often used in place of a base shoe.

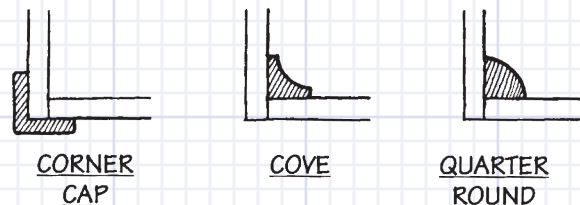





<b>MOULDING NUMBER</b>	<b>PAGE NUMBER(S)</b>	<b>MOULDING NUMBER</b>	<b>PAGE NUMBER(S)</b>	<b>MOULDING NUMBER</b>	<b>PAGE NUMBER(S)</b>
5514	19, 62	A30J	4	B5J	8
A1J	1	A30R	4, 52	B6	8
A2J	1	A31	4, 61	B6R	8, 53
A3J	1	A31J	4	B8	8, 53, 63, 68
A4J	1	A33J	4	B9	8, 53, 62
A5J	1, 61	A34J	4	B10J	8
A5R	1, 51	A35J	4	B11J	9, 65
A6J	1, 61	A35R	4, 52	B12	9, 53
A7	1	A36	4	B13J	9
A7J	1	A37	4	B13R	9, 53
A8	1, 51	A38J	4	B16	9
A8J	1	A39J	5	B17	9
A9J	1	A40J	5	B18J	9, 54
A10J	1, 61	A41J	5	B18P	9
A11	2, 51	A41R	5	B19J	9, 54, 66
A11J	2	A45J	5, 62	B19P	9
A12J	2	A46J	5, 62	B20J	10
A12R	2, 51	A47J	5	B20R	10
A13	2, 61	A48J	5	B21J	67
A14J	2	A49J	5	B23	10
A14R	2, 51	A49R	5, 52	B23J	10
A15J	2	A50J	5	B23R	10, 54
A15R	2, 51	A55J	5	B24	10
A16J	2	A55R	5, 52	B25J	10, 65, 66, 67
A16R	2, 51	A56J	6	B26J	10
A19J	3	A57J	6	B26R	10
A20J	3, 61, 63, 68	A58J	6	B27J	11
A21A	3	A59J	6	B28J	11
A21H	3	A60J	6	B29J	11
A21L	3	A61J	6	B29R	11, 54
A21P	3	A61R	6	B30J	11
A21T	3	A62J	6	B32J	11
A22J	3	A64J	6	B33J	11
A22R	3, 52	A65J	6	B34J	12, 63
A24J	3	A242	7	B35J	12, 65
A24R	3, 52	A1492J7	7	B36	12, 54, 63
A26J	3	A1493J7	7	B38	12, 54
A27J	3	B1J	8	B39	12, 54
A27S	3	B2	8, 53	B39J	12
A28J	4	B2J	8, 65	B40	12, 62
A28R	4, 52	B3J	8	B45	12, 55
A29J	4	B3R	8, 53	B47J	13
A30	4	B4J	8	B49J	13
				B50J	13

<b>MOULDING NUMBER</b>	<b>PAGE NUMBER(S)</b>	<b>MOULDING NUMBER</b>	<b>PAGE NUMBER(S)</b>	<b>MOULDING NUMBER</b>	<b>PAGE NUMBER(S)</b>
B51J	13	D2J	20	EX286	40
B52J	13	D3J	20	EX381	40
		D4	20	EX381K	40
C1J	15, 64	D5	20	EX604	40
C2J	15	D6	20	EX606	40
C3J	15	D8	20	EX607	40
C6J	15, 64	D9	20	EX614	40
C6R	15	D10	20	EX616	40
C7J	15, 64	D10R	20, 55	EX618	41
C8	15, 64	D11	20	EX619	41
C8R	15, 55	D12J	20	EX627	41
C9J	15	D15	20	EX629	41
C12J	15	D16	20	EX630	41
C13J	16	D16F	20	EX634	41
C14J	16			EX638	41
C15J	16	E1J	21	EX640	42
C16J	16	E2	21	EX1400	40
C17J	16	E3J	21		
C18J	16, 64	E4	21, 55	F1	24
C19	16	E5	21	F2	24
C20J	16, 66, 67	E5R	21, 55	F3	24
C22	16	E6J	21, 55	F4	24
C23J	17	E7	21, 55	F5	24
C24J	17	E9	21	F5R	24, 57
C26	17	E10J	21, 66	F6	24
C27J	17	E10R	21	F7	24
C29	17	E12J	21	F7R	24
C30	17	E13J	21	F8	24
C31J	17	E14J	22, 55	F9	24
C32J	17, 64	E15J	22, 56	F11	24
C32R	17, 55	E15K	25, 56	FF12	45
C36J	17	E16	22, 56	FF15	45
C37J	18	E17K	22, 56	FR2	45
C38J	18, 62	E17R	22, 56	FR3	45
C39J	18	E20-4	22, 56	FR3A	45
C40J	18	E20-6J	22, 56	FR4A	45, 59
C42J	18	E20-8	22, 56	FR4B	45, 59
C42R	18	E20-10	22, 56	FR5R	45, 59
C43J	18	E20-12	22, 56	FR6	46
C54J	18	E21J	23	FR7	46
C55J	18	E23J	23	FR8	46
		E24J	23	FR9A	46, 59
D1	20	E25	23	FR9B	46, 59
D2	20	E30J	23	FR9F	46, 59

<b>MOULDING NUMBER</b>	<b>PAGE NUMBER(S)</b>	<b>MOULDING NUMBER</b>	<b>PAGE NUMBER(S)</b>	<b>MOULDING NUMBER</b>	<b>PAGE NUMBER(S)</b>
FR10A	46, 59	HW56	2, 62	K40V	36
FR10B	46, 60			K42V	36
FR19	47	I1J	29	K44	36
FR19C	47	I2J	29	K45R	37
FS12	47	I3J	30	K46V	37
FS24	47	I4J	30	K49	37
FS31	47, 60	I5J	30	K575	38
FS31P	47	I7J	30	K59	37
		I8J	30	K66C	38
G3	25	I10	30, 58	K75SE	38
G4	25			KC14TG	38
G5	25	J3	34	KA1-8	42
G6	25	J3C	34	KA1-10	42
G7J	25	J5J	31	KA4-6	44
G7R	25, 57	J6C	31	KA4-8	44
G8	25	J6J	31	KA4-10	44
G9	25	J6K	31	KA5-8	42
G10	25	J7	31	KA5-10	42
G10R	25, 57	J7F	31	KA5J	43
G11	25	J7J	31	KA6	43
G12	25	J7P	31	KA11	43
G12R	25	J8	31	KA29	43
G13	25, 57	J9	31	KA75	43
G14	25	J19J	32	KA432	44
G16	25, 57	J23J	32		
G16J	25	J24J	32	L1	7
G17	25	J29J	32	L10S	19, 67
G18	25, 57	J37J	32	L11S	19
		J39J	33	L13	26
H1J	26, 61	J47	33	L14	26
H2J	26	J58	33	L15	14
H3	26	J106	33	L16	19
H4	26, 57	J111	33	L17	19
H5-7'	26	J196J	33	L18	20
H5-8'	26			L18M	20
H6J	27	K1-8J	35	L19	20
H7	27, 57	K1-10C	35	L20	20
H8J	27	K1-10J	35	L23	14
H9J	27, 58	K4-6J	34	L24	14
H14	27	K4-8J	34	L25	19
H15J	27	K4-10J	35	L26	23
H16J	27	K5-8J	35, 64	L27	23
H18	27, 58	K5-10J	36	L28	26
H20	27	K6J	36	L29	19

<b>MOULDING NUMBER</b>	<b>PAGE NUMBER(S)</b>	<b>MOULDING NUMBER</b>	<b>PAGE NUMBER(S)</b>	<b>MOULDING NUMBER</b>	<b>PAGE NUMBER(S)</b>
L30	26	OR3	49	WOC005	73
L31	19	OR4	49	WOC006	73
L45	23	OR6	49	WOC007	71, 74
L51	28	OR7	49	WOC008	74
L52	28	OR8	49	WOC009	74
L53	28	OR9	49	WOC010	74
L55	28	OR14	50	WOCV001	71, 72
L56	29	OR22	50	WOHC001	72
L57	29	OS12	50	WOPB001	72
L59	19	OS15	50	WOPM004	72
L60	26	OS16	50	WORS	74
L61	26			WOSP005	74
L106	19	RFB14T	39	WOST001	72
L108	7	RFB16B	39	WOST004	73
L110	7	RFB16T	39	WOWC002	74
L116	26	RFB18B	39	WOWC003	74
L118	24	RFB373	39	WOWS001	71, 73
L120	19			WOWS002	72
L122	28	S1S2E	74		
L123	29	S34112P	71		
L124P	26	S34412P	72		
L130	3	S34512P	70		
		S4SSE	70, 71, 74		
MR14	47, 58	SPBC4	74		
MR14P	47	SPBC6	74		
MR16	47				
MR17	47, 60	W6010	50		
MR18	47	WOBB001	70		
MR19	47	WOBB002	71		
MR20	48, 60	WOBM001	70		
MR21	48	WOBM002	71		
MR21F	48	WOBM003	72		
MR22	48	WOBM004	73		
MR30	48	WOBS001	72, 73		
MR32	48, 60	WOCH001	70		
MR34	48	WOCM001	70		
		WOCM002	70		
OF12	48	WOCM003	70		
OF13	48	WOCM004	71		
OF15	48	WOCM005	72		
OF16	48	WOCM006	73		
OR1	49	WOC001	70		
OR2	49	WOC003	72		
		WOC004	72		

