



Stair Parts Catalog

Beronio
L U M B E R

Beronio

L U M B E R

QUALITY PRODUCTS OFFERED BY BERONIO LUMBER

Decking | Fencing | Finish Lumber | Flooring | Framing
Hardwood Flooring | Paneling | Shingles | Siding
Stair Parts | Windows & Doors | Wainscot | Moulding

Main Showroom at:

2525 Marin Street (at Bayshore)
San Francisco, CA 94124
Tel: (415) 824-4300
Fax: (415) 824-3706

Business Hours:

Monday–Friday 6:00 am - 4:30 pm
Saturday 7:30 am - 1:00 pm

Windows & Doors Showroom at:

196 Napoleon Street
San Francisco, CA 94124
Tel: (415) 824-0621
Fax: (415) 824-7564

Business Hours:

Monday–Friday 7:00 am - 4:30 pm

**SUPPLYING THE BAY AREA WITH
THE FINEST BUILDING MATERIALS
SINCE 1911**

ALTHOUGH WE HAVE TRIED TO APPROXIMATE AS CLOSELY AS POSSIBLE THE ORIGINAL COLOR OF THE WOOD, NATURAL COLOR VARIANCES WILL EXIST WHEN COMPARED TO THE ACTUAL PRODUCT. THERE ARE NO REPRESENTATIONS OR WARRANTIES, EXPRESS OR IMPLIED OF ANY KIND WHATSOEVER, INCLUDING BUT NOT LIMITED TO REPRESENTATIONS OR WARRANTIES OF FITNESS FOR A PARTICULAR PURPOSE OF MERCHANTABILITY, WHICH EXTENDED BEYOND THE DESCRIPTION OF THE FACE HEREOF. SELLER'S LIABILITY SHALL BE LIMITED TO REPLACEMENT OR RESCISSION AT ITS SOLE ELECTION AND IN NO EVENT WILL SELLER BE LIABLE FOR CONSEQUENTIAL OR PUNITIVE DAMAGES. ANY REPRODUCTION OF THIS CATALOG IN WHOLE OR IN PART, OR ANY OTHER UNAUTHORIZED USE WITHOUT THE EXPRESS PERMISSION OF THE BERONIO LUMBER COMPANY IS PROHIBITED.

GLOSSARY 2

ILLUSTRATED REFERENCE - STAIRWAY 3

STAIRWAY INSTALLATION 4-7

STAIRWAY PLANNING 8-9

FULL ROUND HANDRAILS 10-12

PAINT GRADE HANDRAIL SYSTEMS - INTERIOR ONLY 13-14

OAK HANDRAIL SYSTEMS - INTERIOR ONLY 15-16

OAK SUBRAILS 17

OAK BENDING RAIL FORM / CEDAR EXTERIOR RAIL SYSTEMS 18-21

NEWEL POSTS / BALUSTERS 22-23

PRE-PRIMED BALUSTERS 24

OAK NEWEL POSTS 25

OAK BALUSTERS 26

NEWELS / SPECIALTY NEWELS 27

OAK RAIL FITTINGS / ROSETTES 28-30

OAK STARTING STEPS & ACCESSORIES 31

STAIR HARDWARE 32-33

CEDAR NEWEL POSTS 34

CEDAR BALUSTERS 35

CEDAR PORCH POSTS - ARCHITECTURAL 36

WOOD PORCH POSTS 37

POST CAPS 38-39

BALL FINIALS 40

POLY CLASSIC COLUMNS 41

WOOD & ARCHITECTURAL COLUMNS 42

CAPITALS & BASES 43

COLUMN PLAN TYPES 44

Beronio Lumber Company has been well known for quality lumber and wood products since 1911, when it was founded by Antone Vincent Beronio. The original yard was located in San Francisco’s waterfront at Powell and Beach Street. It was moved to its present location in 1942.

It is in this tradition that we take pride in presenting our new Beronio Stair Parts Catalog. Inside you will find guidelines and steps for building stairs, a number of stair plans, as well as photographs and drawings of our wide range of available stair parts.

We welcome your inquiries and suggestions and look forward to working with you.

BALUSTER

Upright pieces that run between handrail and tread or shoerail.

CONTINUOUS RAIL

System where handrail runs over the top of posts. Rail is connected with fittings (return, bends, easing, etc.) to form one, long run.

EASING

Continuous rail fitting used to help make transition from rail to newel, often used with gooseneck fittings.

FINIAL

Turned, decorative cap, or knob, that attaches to the top of the post.

GOOSENECK

Continuous rail fitting used to make transition from stairway to landing.

HANDRAIL

Rail that is grasped for support when using a stairway.

NEWEL

Main posts, or uprights, that support the handrail.

NOSING

Rounded projection of the tread beyond the face of the riser.

PITCH

The angle of ascent or rise of a stairway, defined either in degrees ($33\frac{1}{3}^\circ$) or in rise over a given run (8" up in a 12" run).

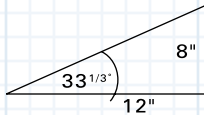
**POST TO POST**

Rail system where handrail is comprised of discrete sections that butt into the side of finial topped posts.

TREAD

The step or walking surface of the stairway.

TURNOUT

A smaller volute supported by newel and two balusters.

VOLUTE

The spiraled end of the railing that is commonly used on the starting step supported by a post and four or five balusters.

- This is by no means a complete guide to code requirements, it is intended only as a guide in selecting and ordering materials.

- A** Right Hand Gooseneck
Riser Level Quarterturn
with Cap
- B** Right Hand Gooseneck
Riser Quarterturn with Cap
- C** Landing Newel
- D** Tread Baluster
- E** Right Hand Volute
- F** Volute Newel
(with Pin through Tread)
- G** Volute Baluster
- H** Starting Step Unit

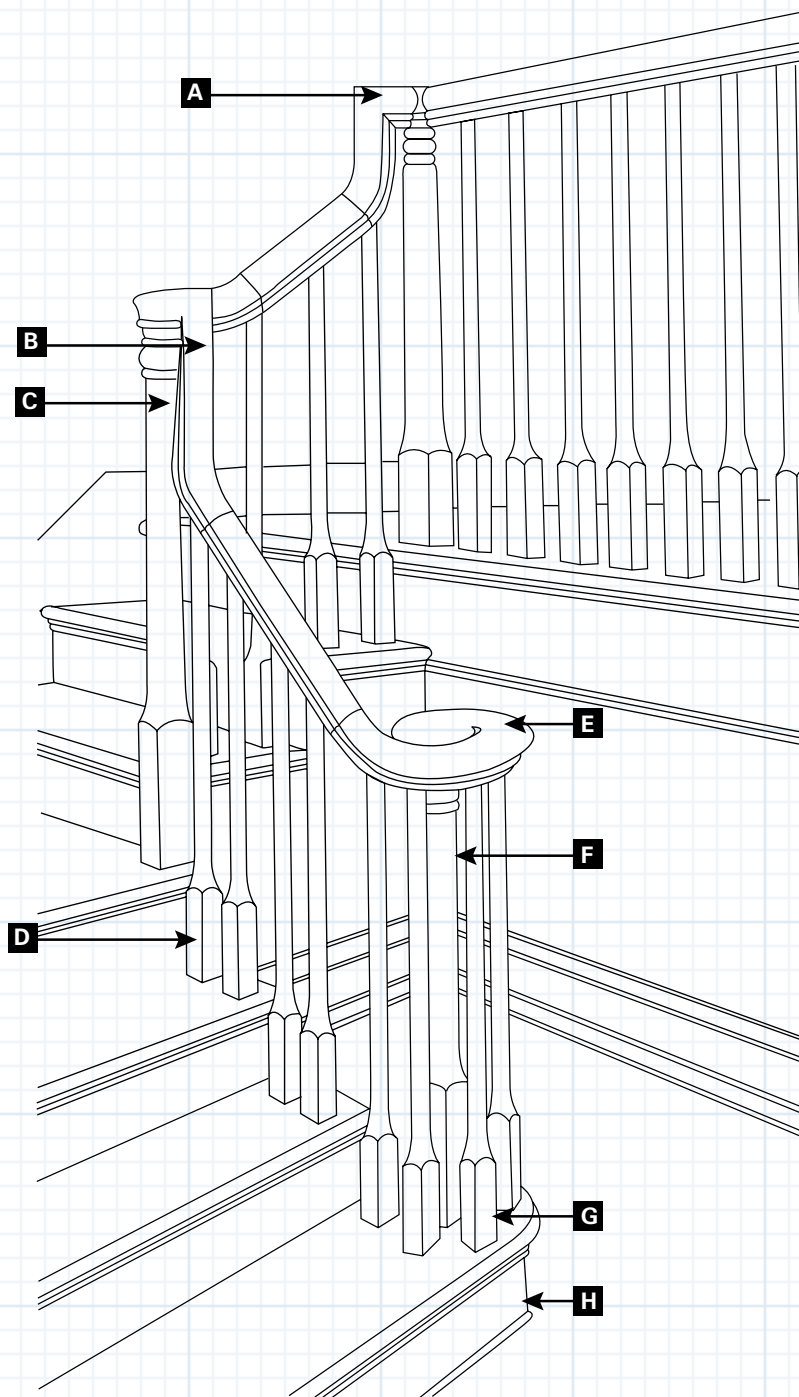

GENERAL REQUIREMENTS

1. All risers must be equal in height for the entire run of the stairway. Treads must be equal in width. A tolerance of less than 1/8" must be kept. This requirement alone means extra care must be taken in planning and laying out.
2. Watch headroom clearances on interior stairs.
3. Tread width must be at least 9".
4. Rise, not riser, cannot exceed 8".
5. Tread overhang (nosing) should not exceed 1 1/2".
6. The ideal rise to run ratio is 7 to 11 or, "the sum of 2 risers and 1 tread should equal 25". The proper rise to run ratio is important in making a stair comfortable to travel.
7. Stairways should be at least 36" wide.

Handrails should be:

- a. 42" high on outdoor decks, landings, balconies.
- b. 36" - 42" high on interior landings, lofts, balconies.
- c. 34" - 39" on stairs, measured from nose to tread.
- d. At least 1 1/2" away from walls (2" is better).
- e. Constructed so that a 4" sphere cannot pass through the balustrade at any point.

The following are general guidelines designed to help plan your stairway and to simplify installation. We have other publications available for detailed construction guidance.

GUIDELINES FOR STAIRWAY INSTALLATION

STEP 1

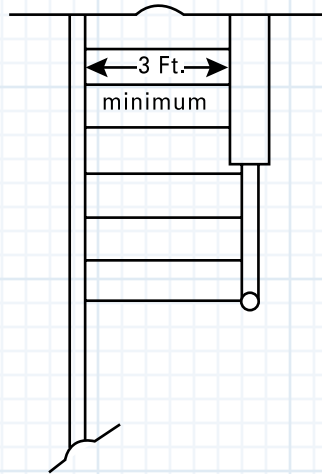

Determine Stair Width

The width should be at least 3' 6"

STEP 2

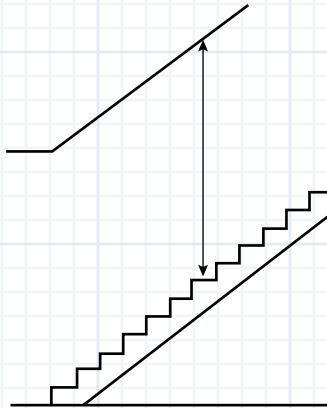

Measure Stair Headroom

Minimum 6' 6"

STEP 3

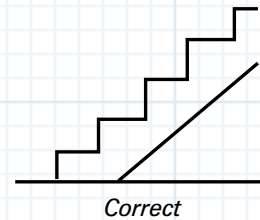
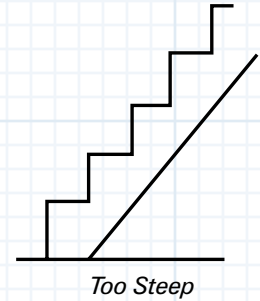
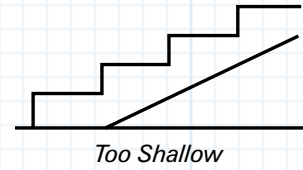

Determine Proper Stair Rise and Run

Stairways should not have risers of more than 7 3/4" and not less than 7". Tread width (run) should not be less than 9 1/2", not including nosing. The degree of angle (pitch) of a stairway should be between 32 1/2° and 37° for safety.

STEP 4

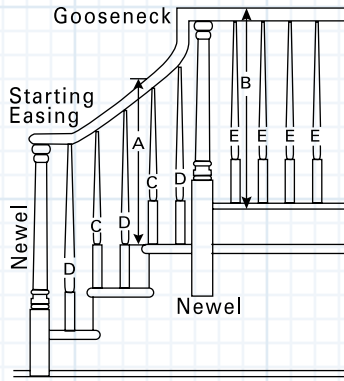

Determine Rail Heights:

Code Requirements:

- A. 34" to 38"
We recommend 34" to 36"
- B. 36" to 42"
We recommend 36"

Most codes now use 36" as their minimum.

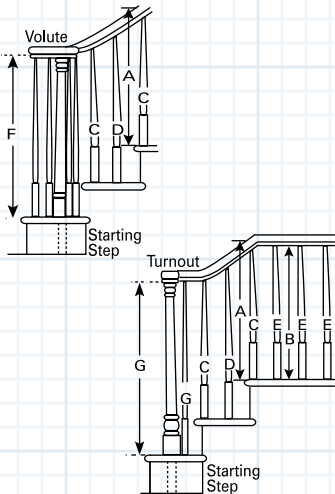

General Requirements:

(letters are keyed to illustration)

- A. 34" - 38"
- B. 36" - 42"
(36" interior, 42" exterior)
- C. 34" Baluster
- D. 36" Baluster
- E. 39" or 41" Baluster
- F. 39" - 41" Baluster
(under Volute, Turnout)

STEP 5

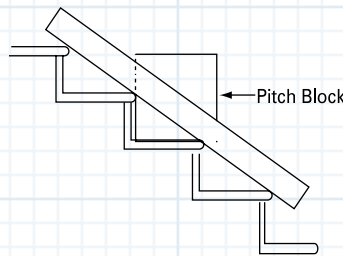

To Find the Pitch:

1. Cut a square piece of plywood to a dimension slightly larger than the tread width and riser height.
2. Obtain a straight edge 4" or longer.
3. Place the straight edge on the stairway (or nosing) of 4 or more treads (excluding the first tread).
4. Cut the plywood square along this line to form the "pitch block."

STEP 7

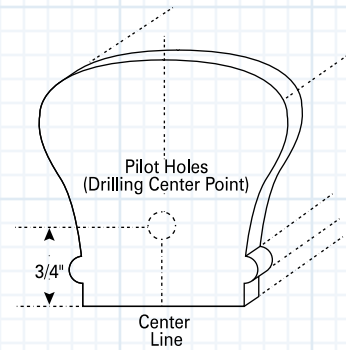

Make a Template:

1. Cut a piece of rail approximately 1/4" thick.
2. Drill a 1/4" hole on center line and drill up 3/4" from the bottom.
3. Mark one side "fitting" and the other side "rail."

STEP 6

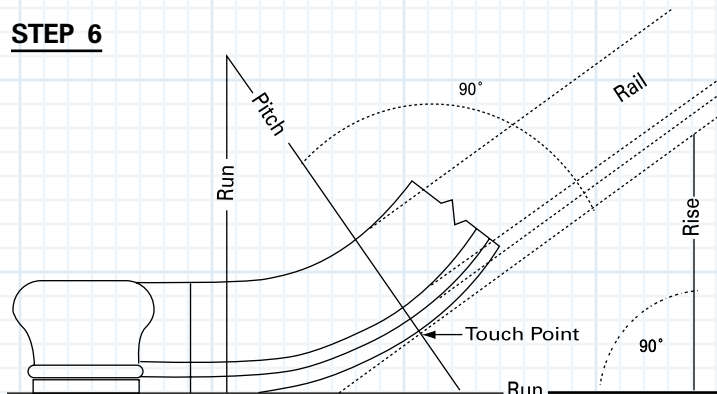

To Cut Fittings to Attach to Handrail:

Place fitting and pitch block on a flat surface. Move the pitch block to the fitting to the point they touch, and mark this point. Turn the pitch block upright, mark cutting line, and make cut square to the rail. Cut the rail to length after fittings are cut and placed. All rail cuts are square.

STEP 8

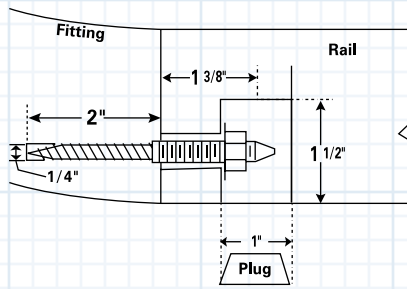

Drill Holes in Fittings and Rail:

After fittings have been cut to the proper pitch:

1. Take drilling template and place side marked "fitting" on the fitting and mark center hole.
2. Drill a 1/4" hole into the fitting 2" deep.
3. Place drilling template side marked "rail" on the rail and mark center hole.
4. Drill a 3/8" hole into rail at least 1 1/2" deep.
5. Drill a 1" hole centered on the bottom, 1 1/2" setback.
6. Install rail bolt and plug. Use "vise grips" to insert lag screw end into 2" fitting. Insert machine thread end through oversized hole in the end of the rail. Put nut and washer on bolt through 1" bottom hole and finger tighten, align rail and fitting and finish tightening with 1/2" box end wrench. Sand joint between fitting and rail until you can't feel the joint. Insert taper plug, but do no glue. Tightening may be required later.

STEP 9

Drill Treads and Rail for Balusters:

By locating equal centers on the treads, use a level or plumb to locate centers underneath rail. Drill 5/8" holes in treads and rail on the center marks. A speed bore (butterfly) bit is recommended. Drill rail hole approximately 1 1/2" deep so that baluster can be lifted enough to allow dowels to drop into tread holes. Use glue in both holes. Line up bottom squares before glue sets. If square top balusters are used, toe nail the "up" side as shown. Balusters are made to cut up to 3" off the top without changing the sizes.

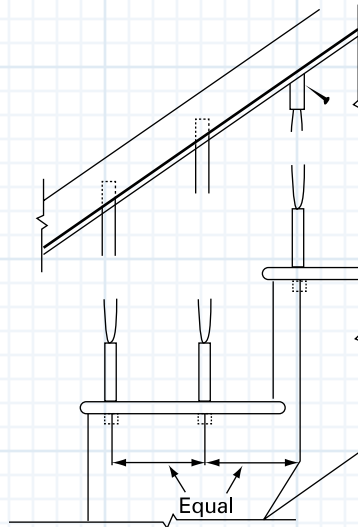

STEP 10

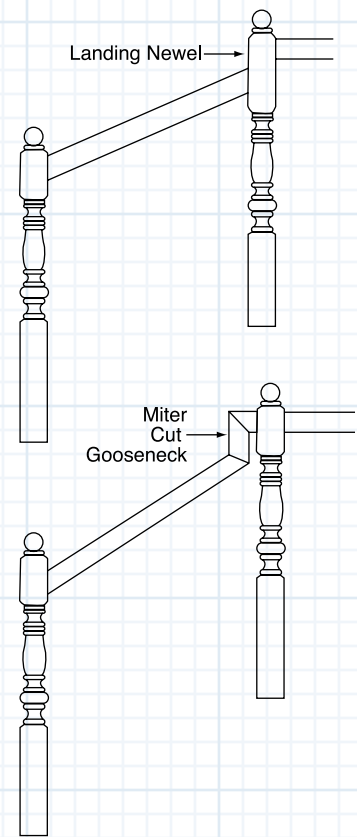

In Post-to-Post Installations, either:

1. Use landing newels (with longer square top sections) to make transition from stair rail to landing rail.

OR

2. Make rail goosenecks by miter cutting rail as shown (or use stock fittings when using 6010 rails).

PLAN A

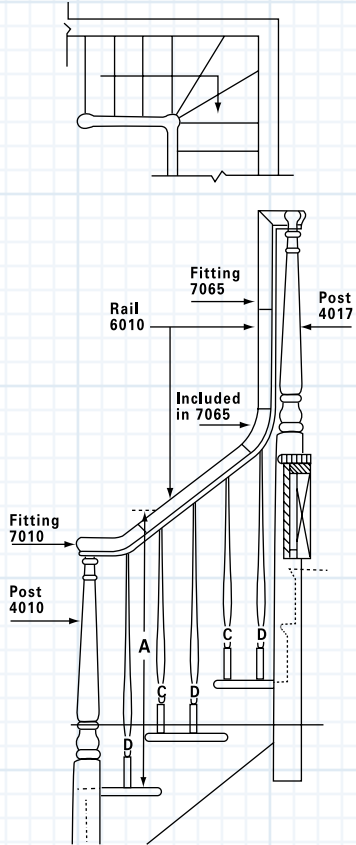

Continuous Rail

Fitting to 4 riser gooseneck at a 3 pie 90° landing. The gooseneck fitting has the bottom easing unattached to add a piece of rail.

PLAN B

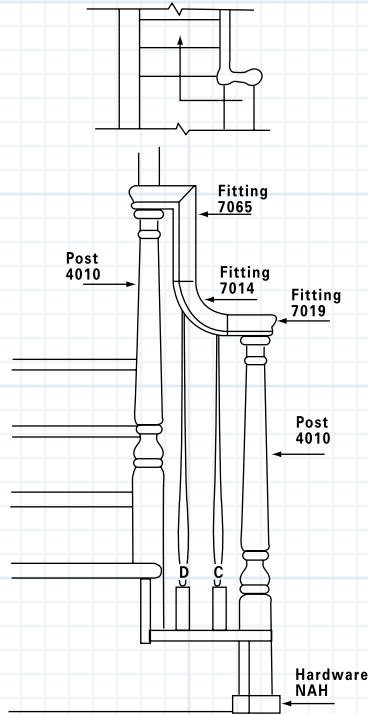

Continuous Rail

By using a combination of fittings to go up one step to a landing and turning 90° to continue up.

PLAN D

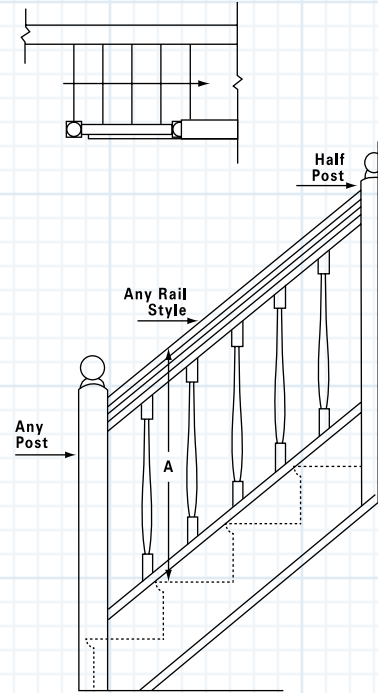

Newel to 1/2 Newel / Rail

Shoe and fillet are set on top of the exposed boxed stringer. Heavier rail and balusters are usually used.

PLAN C

This plan relates to Step 10 in Guidelines for Stairway Installation.

Post to Post using Landing Newel

Newel to Newel Rail

Notice how the longer top square on the landing newel allows rail to intersect at two different levels. More massive rail balusters can be used.

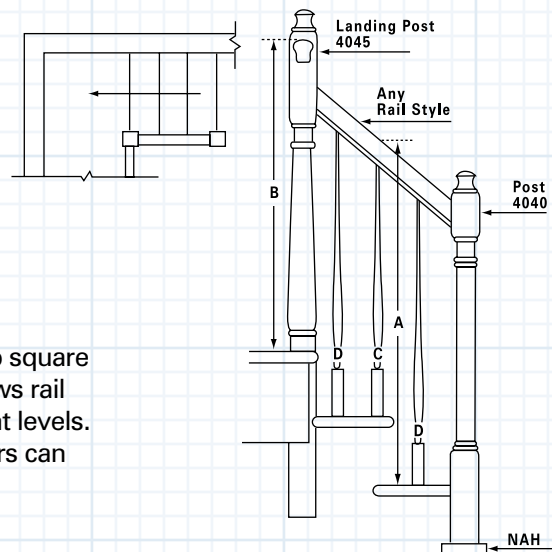

PLAN G

Continuous Rail

Starting easing to an overeasing for a graceful free flow effect. Note how balusters anchor to skirt board giving the structural requirements. Use longer length balusters.

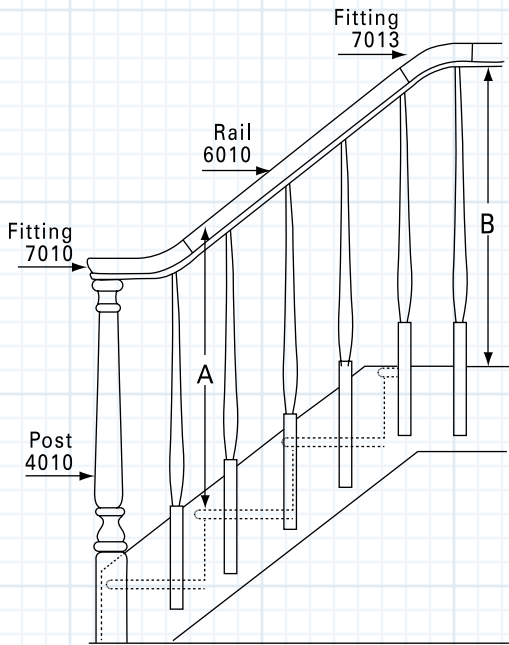
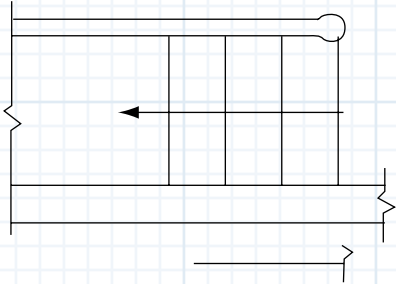

PLAN H

Continuous rail to the 2nd floor and returning 180°. A fitting designed for a newel should be used if the level rail is more than 4 feet long.

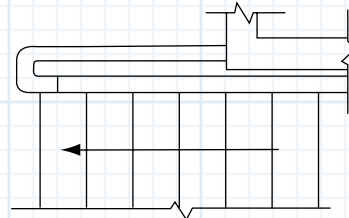

Optional 180° fitting for a newel
7095 W/C

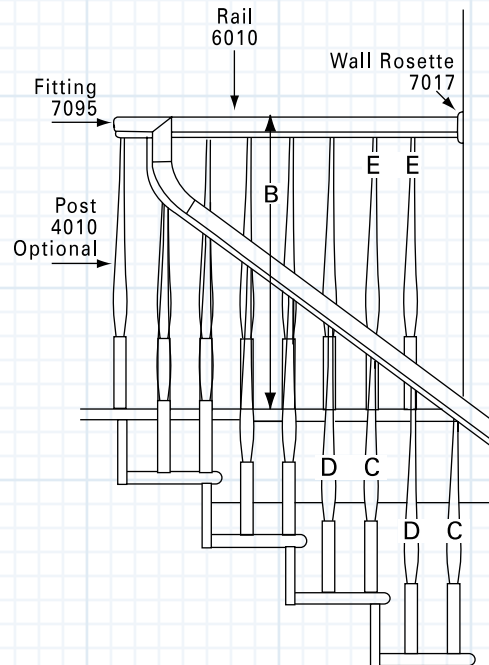
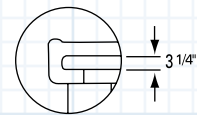

FULL ROUND HANDRAILS



SIZE	SPECIES	RAIL	RETURN	BEND	EASING	ROSETTE
1-1 1/2"	FIR	FR8	FR8R	FR8B	FR8E	FR8W
1-1 1/2"	MAHOGANY	MR30	MR30R	MR30B	MR30E	MR30W
1-1 1/2"	OAK	OR4	OR4R	OR4B	OR4E	OR4W
1-1 1/2"	REWOOD	MR21	MR21R	MR21B	MR21E	MR21W
1-1 1/2"	MAPLE	MR34	MR34R	MR34B	MR34E	MR34W
1 3/4"	FIR	FR6	FR6R	FR6B	FR6E	FR6W
1 3/4"	MAHOGANY	MR16	MR16R	MR16B	MR16E	MR16W
1 3/4"	MAPLE	MR22	MR22R	MR22B	MR22E	MR22W
1 3/4"	OAK	OR1	OR1R	OR1B	OR1E	OR1W
2"	CHERRY	MR19	MR19R	MR19B	MR19E	MR19W
2"	MAPLE	MR18	MR18R	MR18B	MR18E	MR18W
2"	OAK	OR2	OR2R	OR2B	OR2E	OR2W
2"	REDWOOD	MR17	MR17R	MR17B	MR17E	MR17W

RETURNS

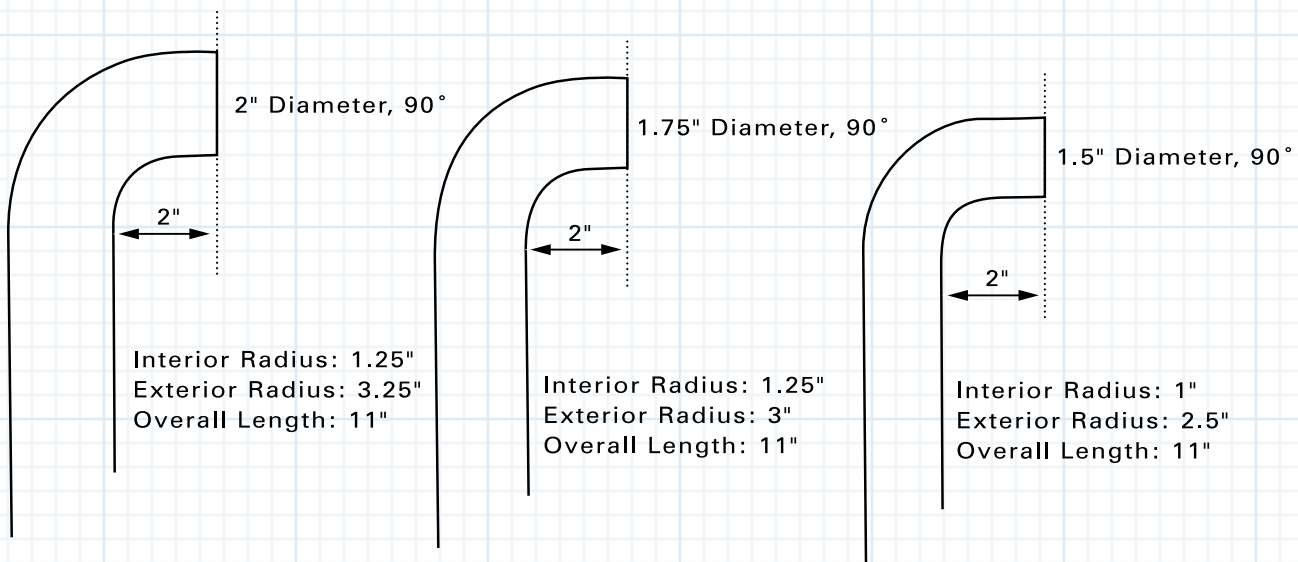

LEVEL QUARTER TURNS

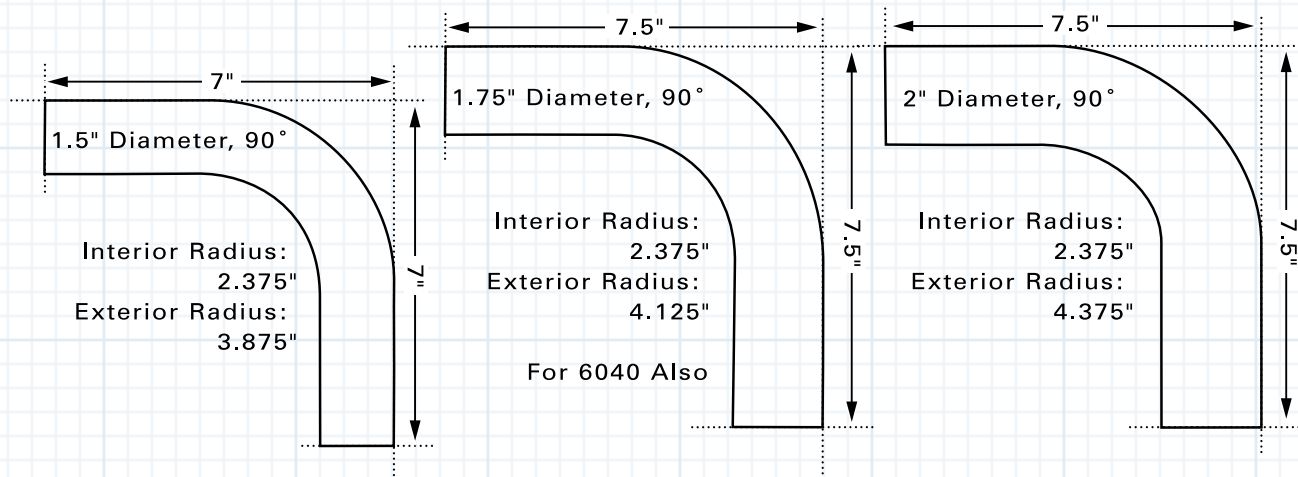

EASINGS, 30°

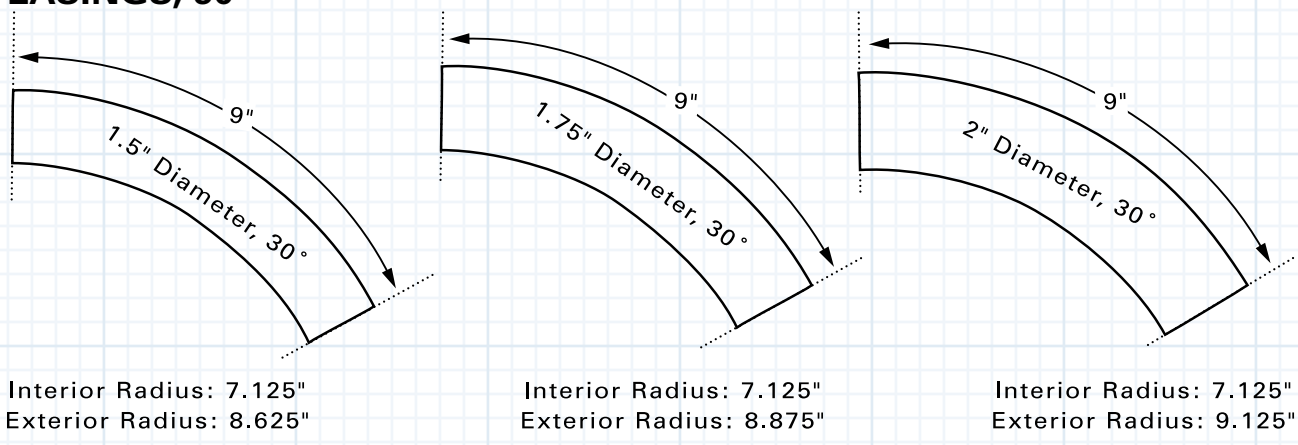

FULL ROUND HANDRAILS

1 1/2"	
FR8	Fir
MR30	Mahogany
MR34	Maple
OR4	Oak
MR21	Redwood

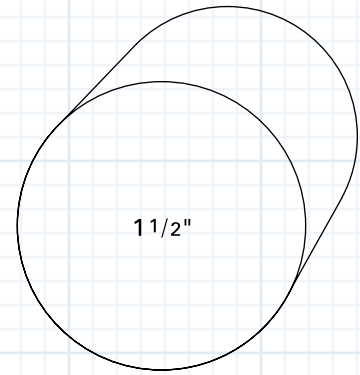

1 3/4"	
FR6	Fir
MR16	Mahogany
MR22	Maple
OR1	Oak

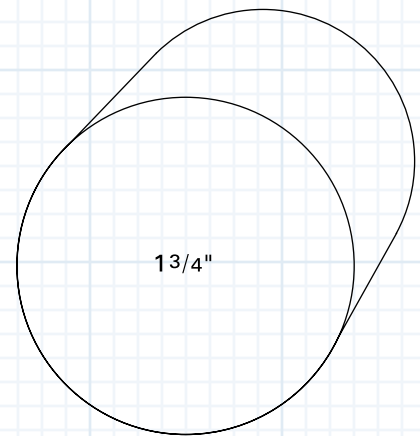

2"	
MR19	Cherry
MR18	Maple
OR2	Oak
MR17	Redwood

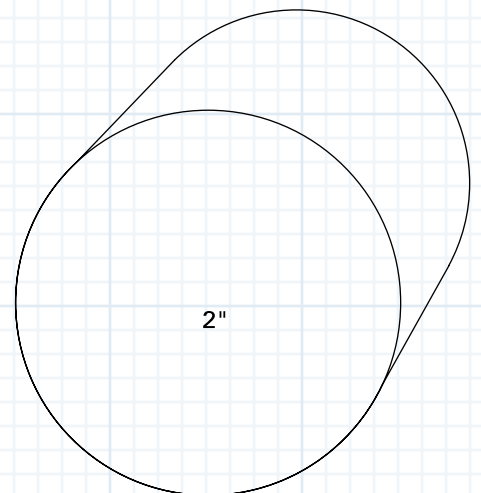

PAINT GRADE HANDRAIL SYSTEMS

FR7
Wall Rail
1 1/4" x 27/32"

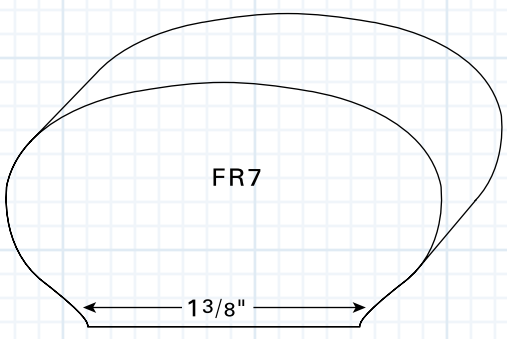

FR3A
Hemlock Newport Rail
2 1/4" x 2 1/4"

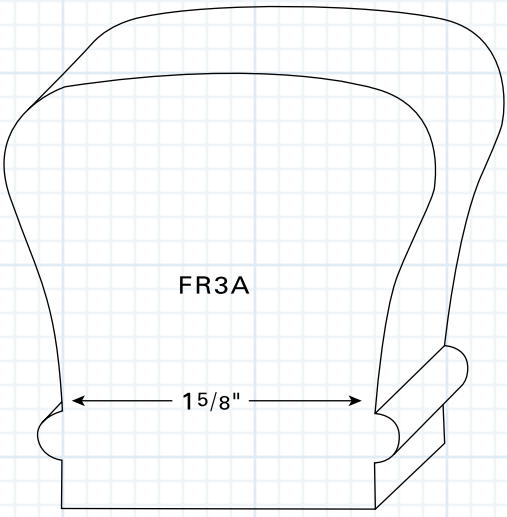

FR3
Hemlock Newport Rail
2 1/4" x 2 1/4"
(1 1/4" Plow)

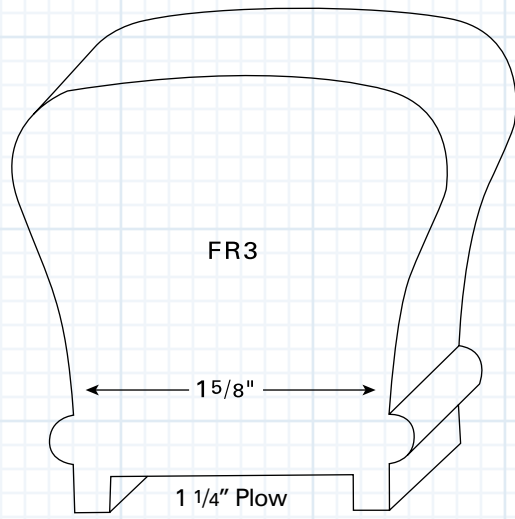

FF12
Hemlock Fillet
1/4" x 1 1/4"

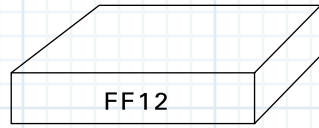

FS12
Hemlock Shoe
11 3/16" x 2 1/2"
(1 1/4" Plow)

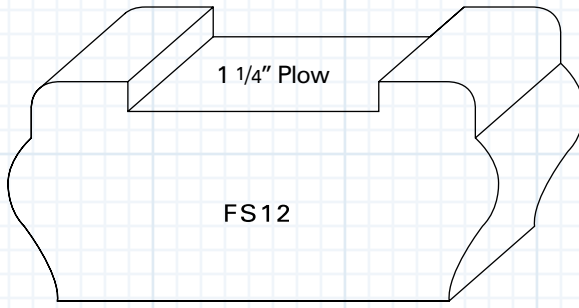

PAINT GRADE HANDRAIL SYSTEMS

MR14P
 Poplar Rail
 2 5/8" x 21 5/16"
 (1 5/8" Plow)

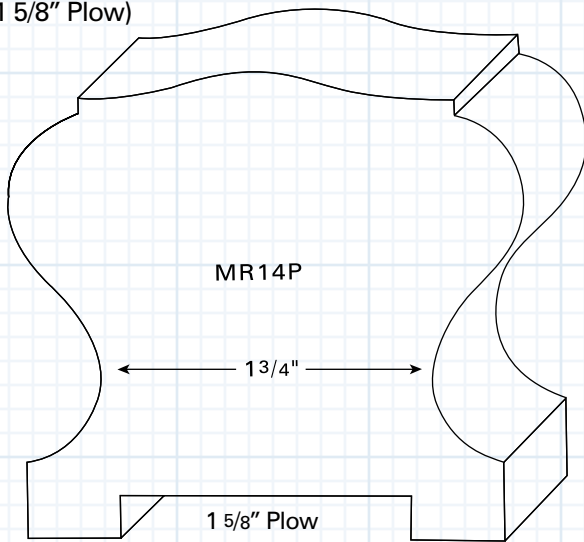

FR2
 Hemlock Hampton Rail
 2 1/4" x 2 1/4"
 (1 5/8" Plow)

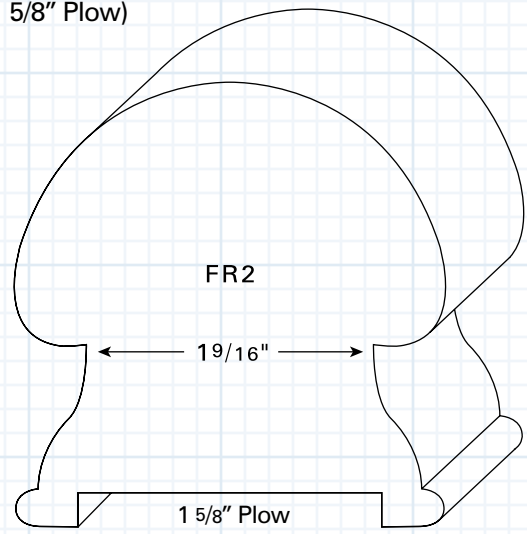

FF15
 Hemlock Fillet
 1/4" x 1 5/8"

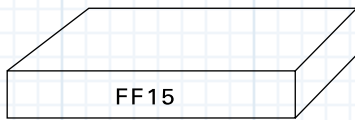

FF15
 Hemlock Fillet
 1/4" x 1 5/8"

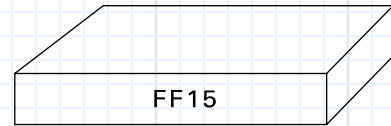

FS31P
 Poplar Shoe Rail
 7/8" x 3 1/8"
 (1 5/8" Plow)

FS31
 Cedar Shoe Rail
 7/8" x 3 1/8"
 (1 5/8" Plow)

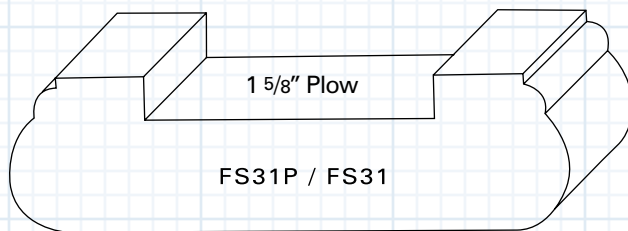

FS24
 Hemlock Shoe
 1 1/4" x 2 1/2"
 (1 5/8" Plow)

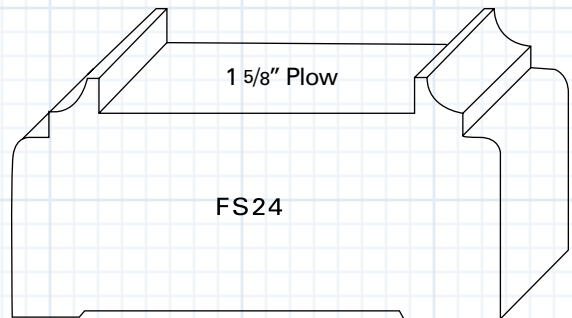

OAK HANDRAIL SYSTEMS

OR3
Oak Oval Rail
1 1/8" x 2 1/4"

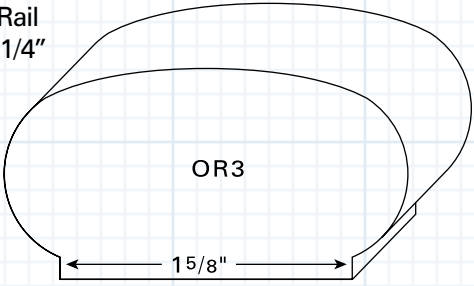

OR6
Oak Newport Rail
2 3/8" x 2 1/4"

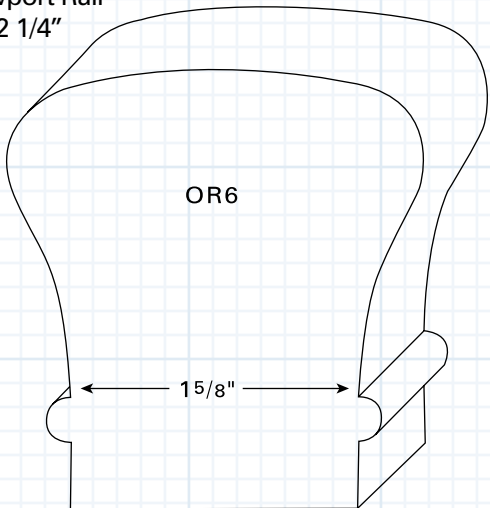

OR8
Oak Colonial Rail
2 3/8" x 2 7/8"

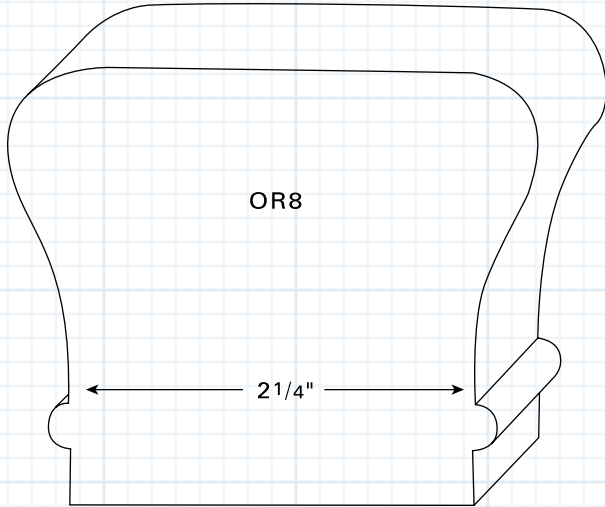

OR7
Oak Newport Plowed Rail
2 3/8" x 2 1/4"
(1 1/4" Plow)

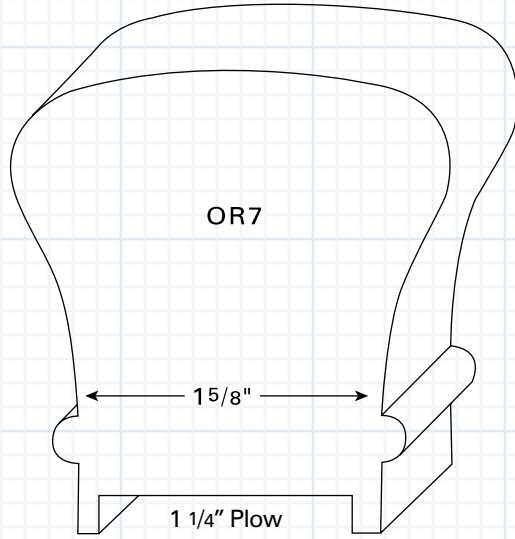

OF12
Oak Fillet
1/4" x 1 1/4"

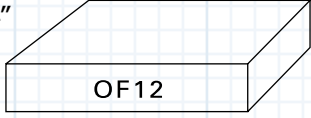

OF13
Oak Fillet
3/8" x 1 1/4"

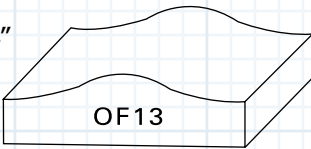

OS12
Oak Shoe
3/4" x 2 3/8"
(1 1/4" Plow)

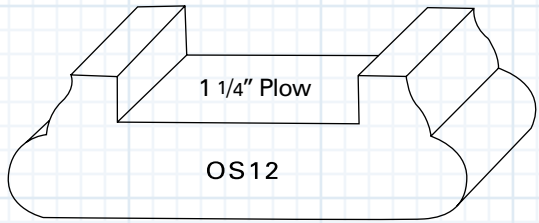

OAK HANDRAIL SYSTEMS

OR14
Oak Washington Rail
2 1/2" x 3"
(1 3/4" Plow)

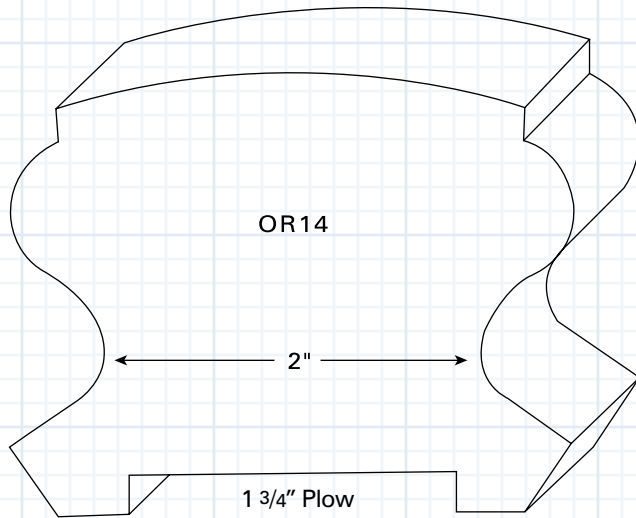

OF16
Oak Fillet
1 5/16" x 1 3/4"

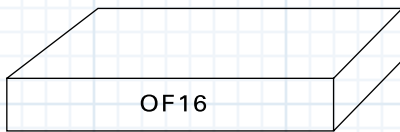

OS16
Oak Shoe
7/8" x 3 1/8"
(1 3/4" Plow)

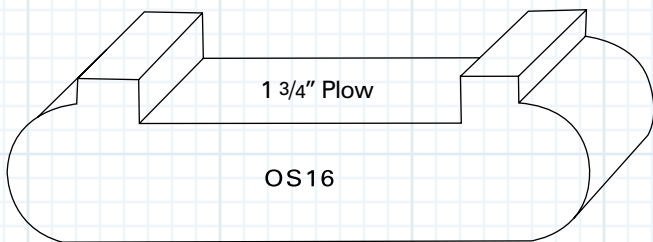

OR9
Oak Junior Hampton Rail System
1 3/4" x 2 1/2"

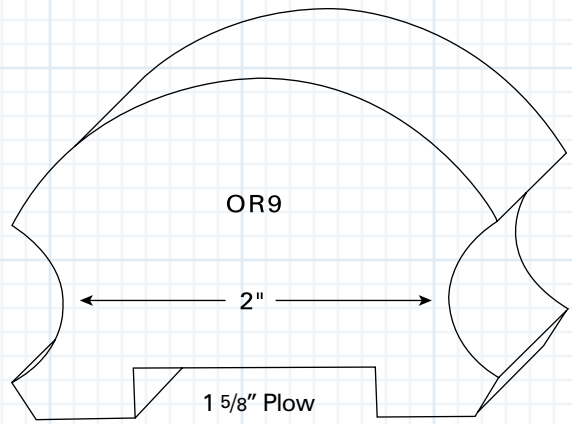

OF15
Oak Fillet
5/16" x 1 5/8"

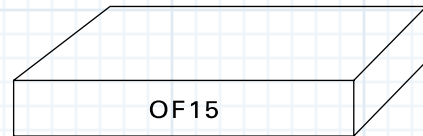

OS15
Oak Shoe
3/4" x 2 1/2"

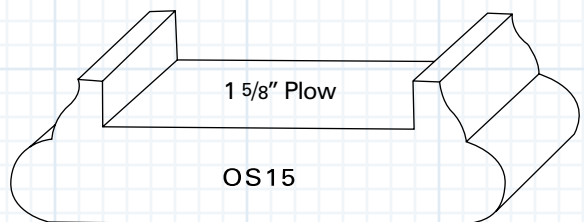

PAINT GRADE HANDRAIL SYSTEMS

OSR12
 Oak Subrail
 Use with Junior Hampton Oak Rails
 (for use with Oak or Fir 1 1/4" baluster)

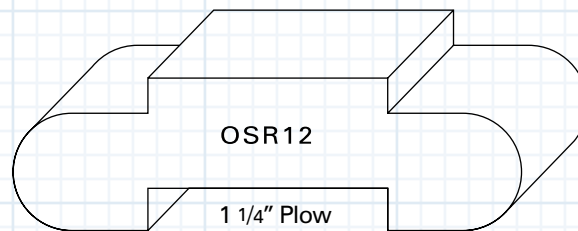

OSR15
 Oak Subrail
 Use with Junior Hampton Oak Rails
 (for use with Fir 1 5/8" baluster)

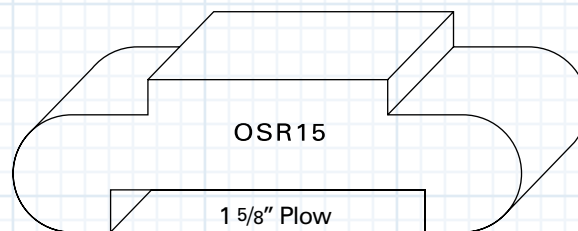

OSR16
 Oak Subrail
 Use with Junior Hampton Oak Rails
 (for use with Oak or Fir 1 3/4" baluster)

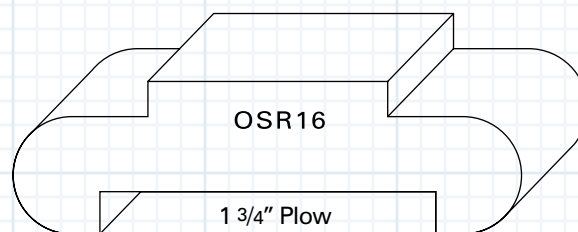

OAK BENDING RAIL AND FORM

For the OR6 and OR7 Rail
 Available in Fir
 FR3 Fir Rail
 FR3A Fir Rail

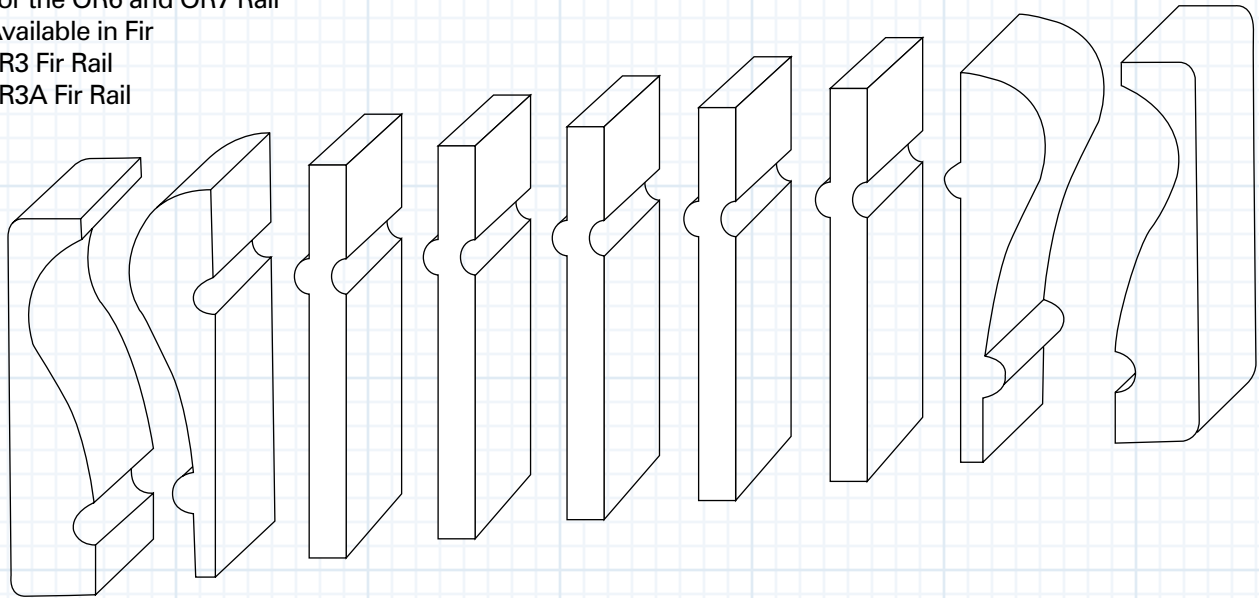

OR11 Form

OR12 Rail

OR11 Form

CEDAR EXTERIOR RAIL SYSTEMS

FR9A
 Red Cedar / Redwood Handrail
 1 1/2" x 2 1/4"

FR9B
 Red Cedar / Redwood Handrail
 1 5/8" x 3 1/2"

FR9F
 Red Cedar / Redwood Foot Rail
 1 1/2" x 3 1/2"

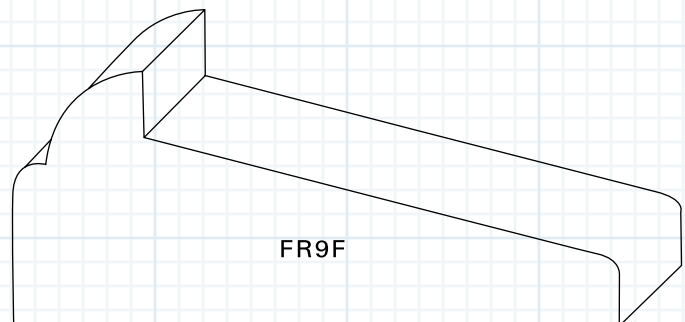
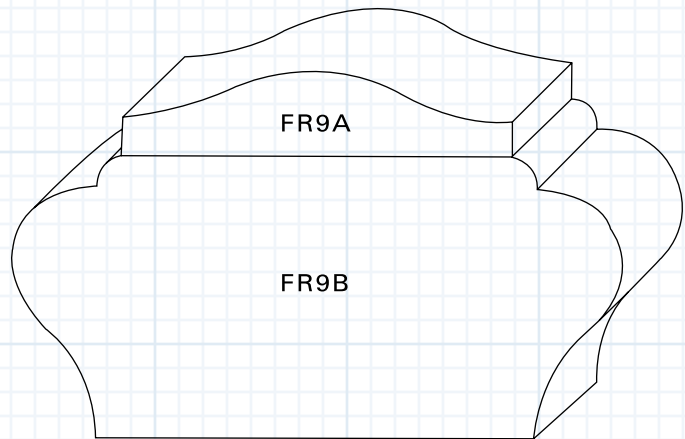

CEDAR EXTERIOR RAIL SYSTEMS

MR14
Cedar Rail
2 5/8" x 2 1/16"
(1 1/2" Plow)

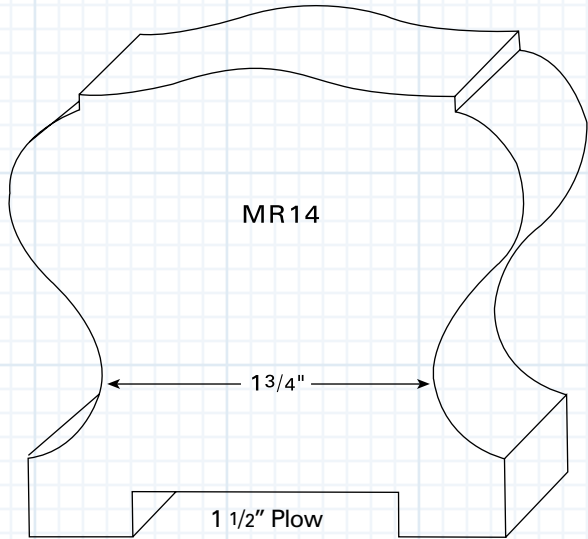

FS31
Cedar Shoe Rail
7/8" x 3 1/8"
(1 1/2" Plow)

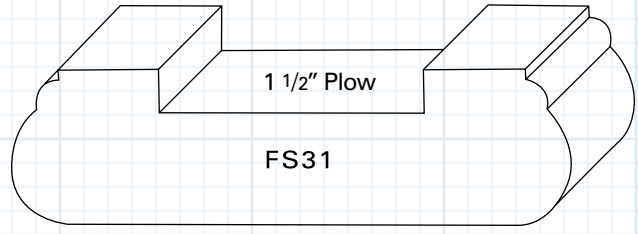

EXTERIOR RAILS

Red Cedar/ Redwood Handrail

FR10A

1 1/16" x 3 5/8"

FR10B

1 1/2" x 5"

FR4A

Rail Cap

FR4B

Rail Side

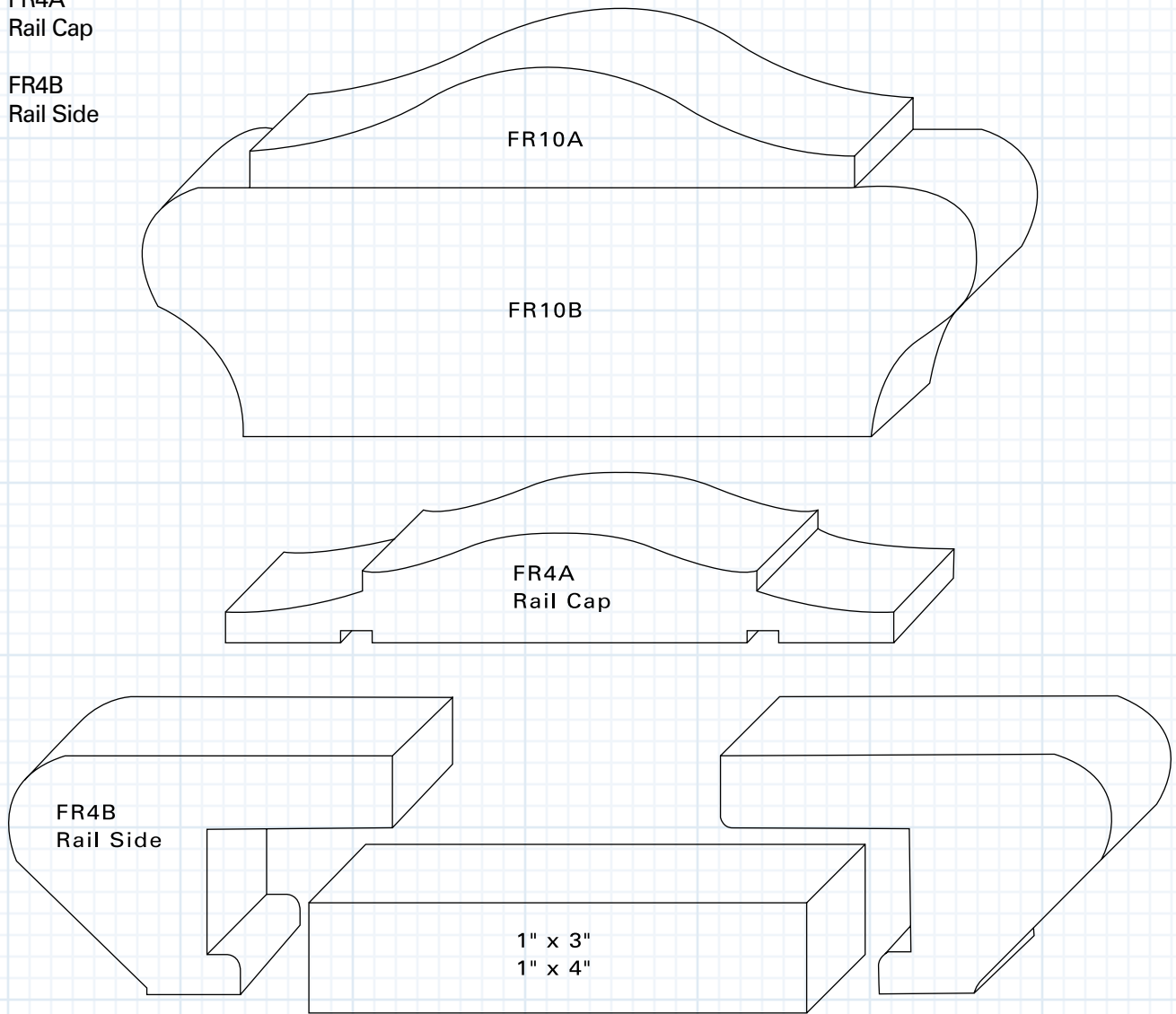

1" x 3" For use with 3" x 3" Baluster

1" x 4" For use with 4" x 4" Baluster

EXTERIOR RAILS

FR5R
 Redwood Mushroom Plowed Rail
 1 1/2" X 2 1/4"
 (3/4" Plow)

IR1A- Ipé Rail
 1 1/4" x 41 5/16"

IR1B - Ipé Subrail
 3/4" x 3 3/8"

MR32
 Red Cedar/ Redwood Stair Rail
 2 1/4" x 1 5/8"

MR20
 Redwood Handrail
 5 1/2" x 1 1/2"

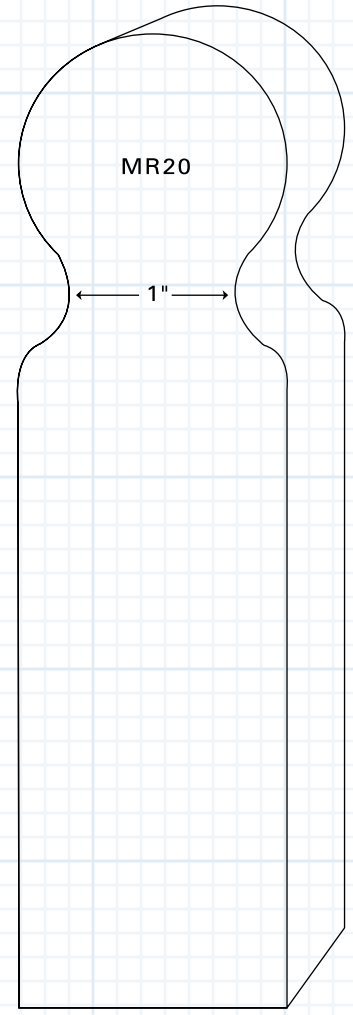
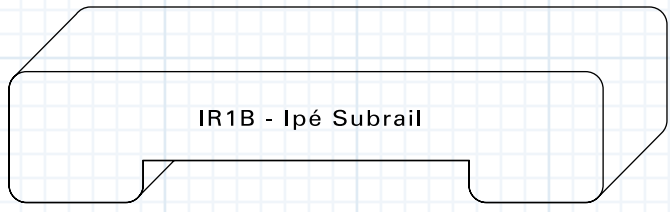
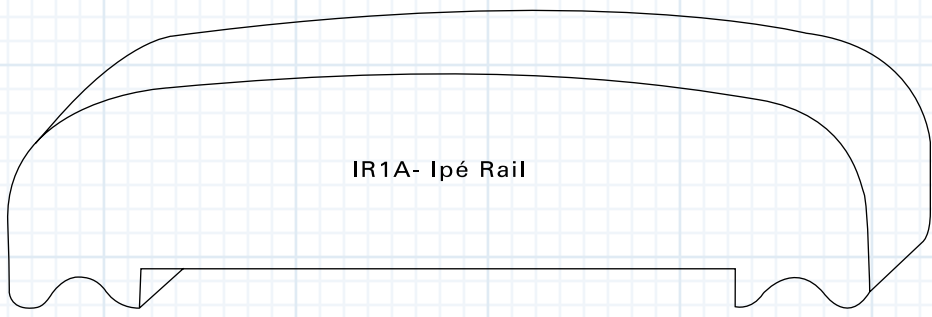
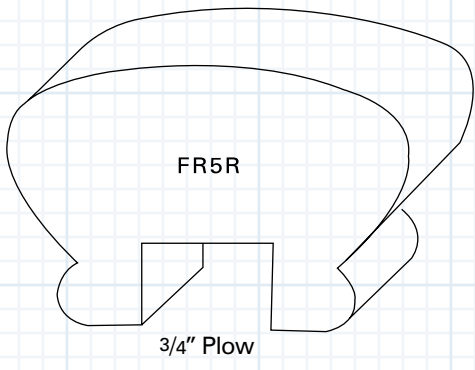
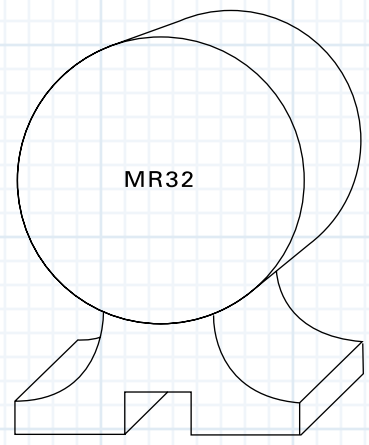

NEWEL POSTS

FN1
Plain
W- 3 5/16" H- 48"
W- 3 5/16" H- 60"

FN2
Hampton
W- 3 5/16" H- 48"
W- 3 5/16" H- 60"

FN3
Colonial
W- 3 5/16" H- 48"
W- 3 5/16" H- 60"

FN5
Box Newel (Poplar)
W- 6 1/4" H- 55"

FN5B
Box Newel (Poplar)
W- 5 1/2" H- 56"

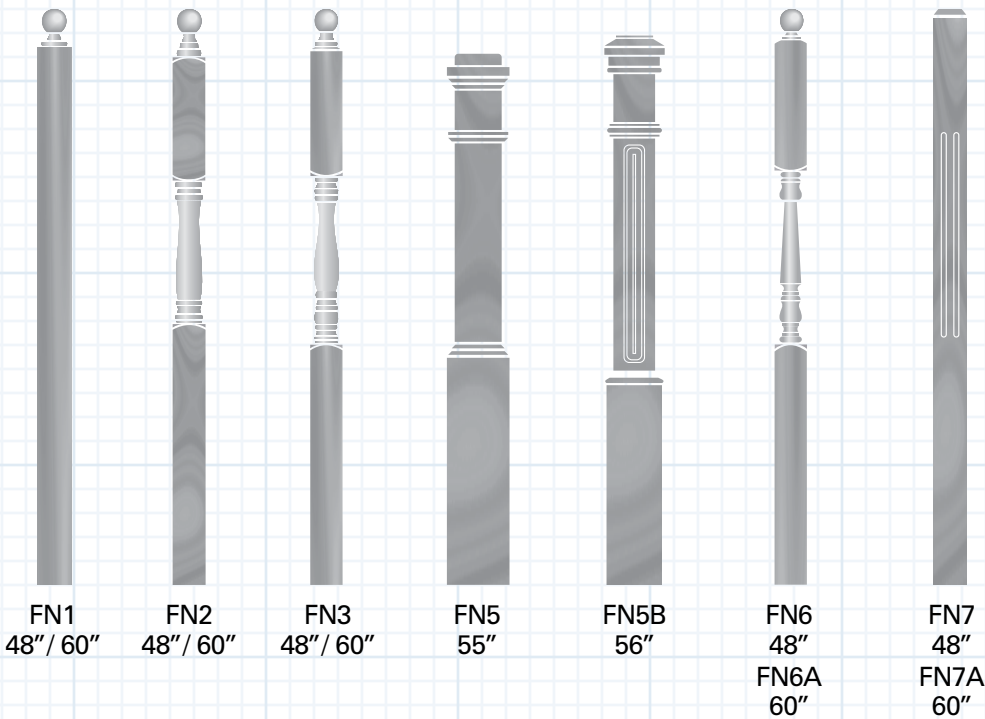

FN1 48" / 60"	FN2 48" / 60"	FN3 48" / 60"	FN5 55"	FN5B 56"	FN6 48" FN6A 60"	FN7 48" FN7A 60"
------------------	------------------	------------------	------------	-------------	---------------------------	---------------------------

FN6 & FN6A Pacific			FN7 & FN7A Double Flute		
FN6	W- 3 1/4"	H- 48"	FN7	W- 3 1/4"	H- 48"
FN6A	W- 3 1/4"	H- 60"	FN7A	W- 3 1/4"	H- 60"

**BALUSTERS
1 1/4"**

FB1
Georgian Pin Top
34" / 36" / 42"

FB3
Square
36" / 42"

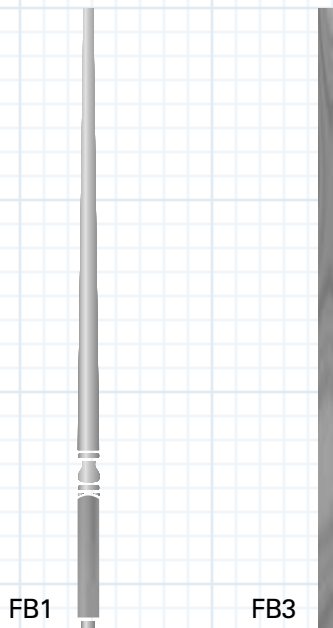

FB1 FB3

BALUSTERS

1 5/8"

FB4

South Hampton

32" / 36"

FB5

Square

36" / 42"

FB6

Colonial

12" / 32" / 36" / 42"

FB8

Double Flute

36"

FB9

Pacific

36"



FB4



FB5



FB6



FB8



FB9

BALUSTERS

3" x 3"

4" x 4"

FB6

Colonial

W- 2 9/16"

3" x 3"

12" / 18" / 24" / 28" / 36"

FB6

Colonial

W- 3 5/16"

4" x 4"

24" / 32" / 36"



FB6
3" X 3"



FB6
4" X 4"

PRE-PRIMED BALUSTERS

1 1/4"

PB1
Newport
34" / 36" / 41"

PB2
Traditional
34" / 36" / 41"

PB3
Hampton
34" / 36" / 41"

PB5
Plain Square
36" / 41"

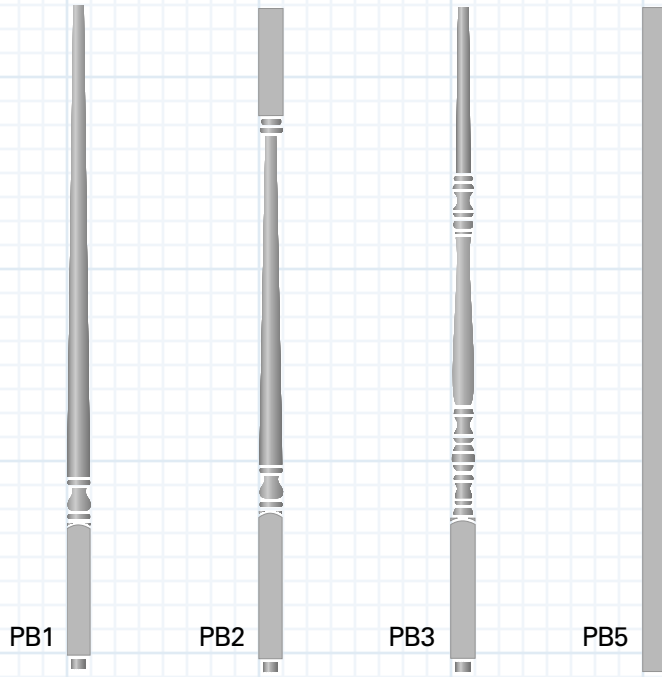

PRE-PRIMED BALUSTERS

1 3/4"

PB4
South Hampton
36" / 42"



OAK NEWEL POSTS

4040
Mushroom Top
W-3" H-48"

4045
Mushroom Top
W-3" H-54"

4350
Junior Hampton
W-3" H-48"

4351
Junior Hampton
W-3" H-54"

4500
Hampton
W-3 1/2" H-48"

4505
Hampton
W-3 1/2" H-56"

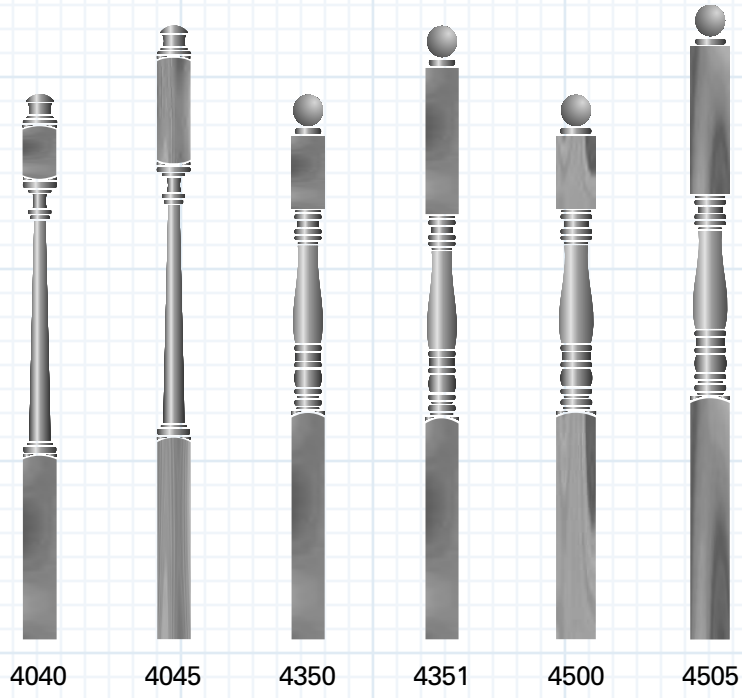

4040 4045 4350 4351 4500 4505

3548
Plain
W-3 1/2" H-48"

3556
Plain
W-3 1/2" H-56"

4004
Plain Ball Top
W-3 1/2" H-48"

4005
Plain Ball Top
W-3 1/2" H-56"

4010
Pin Top
W-3" H-43"

4012
Pin Top
W-3" H-43"

4015
Pin Top
W-3" H-62"

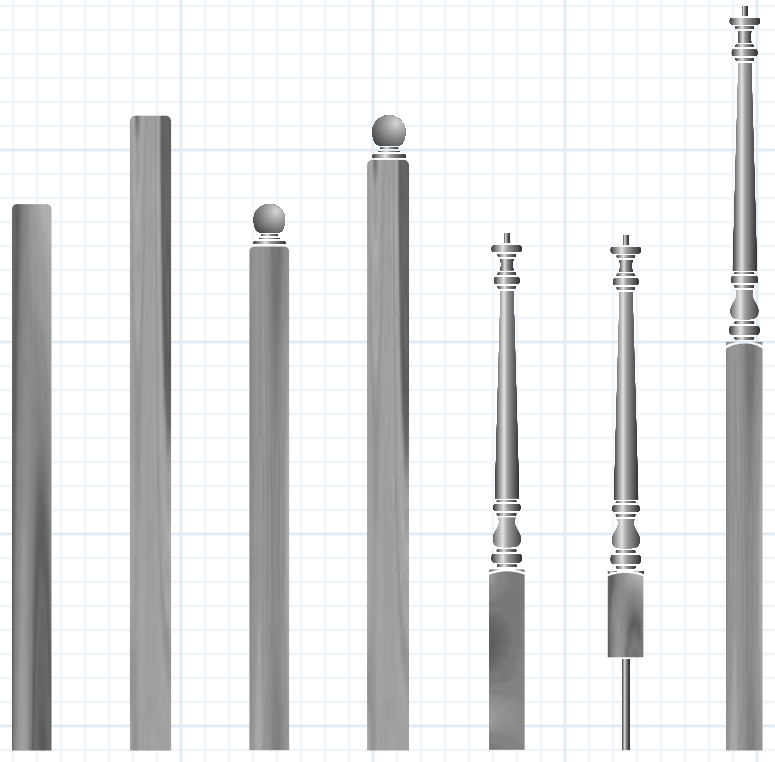

3548 3556 4004 4005 4010 4012 4015

OAK BALUSTERS

1 1/4"

OB1
Georgian
34" / 36" / 41"

OB2
Junior Hampton Pin
34" / 36"

OB4
Junior Hampton Square Top
36"

OB5
Square
36"

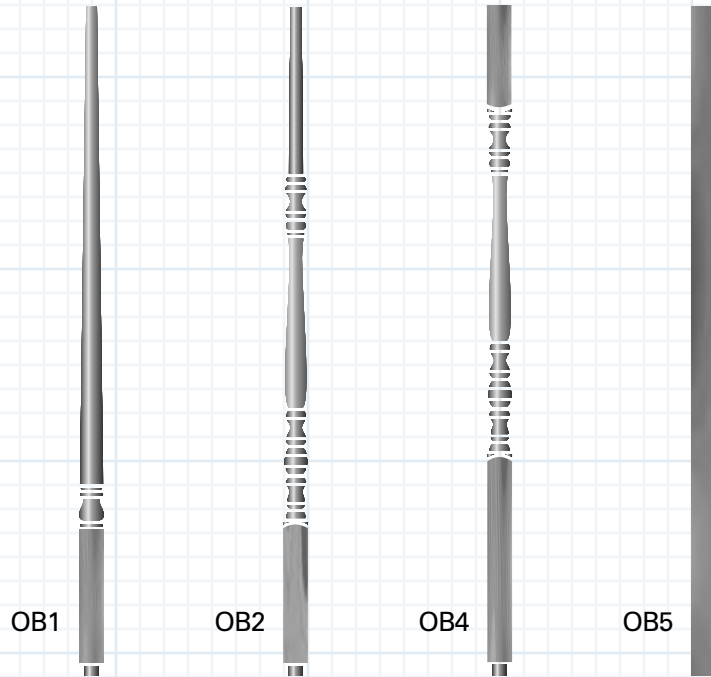

OAK BALUSTERS

1 3/4"

OB6
Hampton
36"

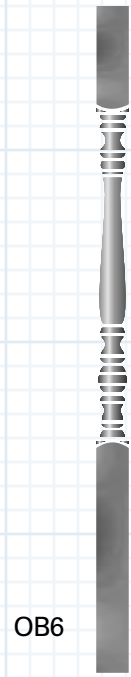

SPECIAL ORDER

NEWELS

Available in Oak and Maple

- Caps shipped separately for ease of installation.
- Detailing deeply trouted into walls of newel. No mouldings to separate. No nail holes or seams to fill.
- Surfaces sanded and edges eased to speed the finishing process.
- Special box design cuts shipping costs while providing solid newel look.
- Also available without routing when detailing is desired only on a starting newel.
- Call for quotes on Maple and other hardwoods as well as alternative inlays, 7" or larger newels and bottom skirts.

Choice of Caps:

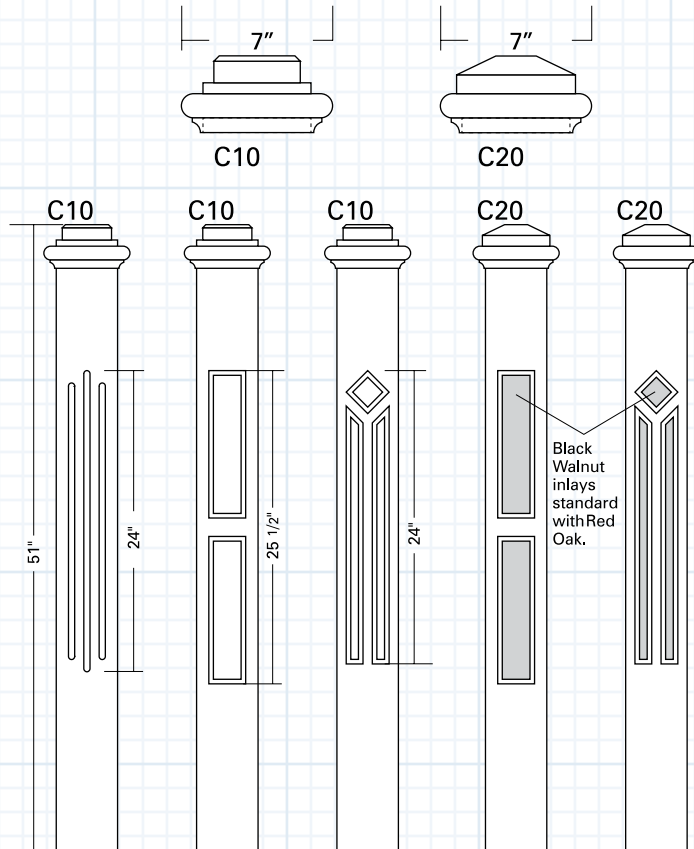

Nominal 5" x 5" x 48"	145RO	245RO	345RO	245RO-BW	345RO-BW
Nominal 5" x 5" x 60"	155RO	255RO	355RO	255RO-BW	355RO-BW

Designs and locations on the newel may vary slightly.

SPECIAL ORDER

SPECIALTY NEWELS

3 1/2" x 3 1/2" x 53 - 68"

Available in Oak, Maple, Paint Grade, Cherry and Mahogany

Each newel has matching rails and balusters.

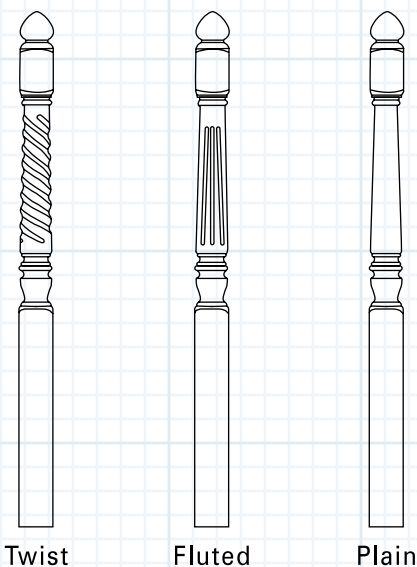

OAK RAIL FITTINGS
OR6 - OR7

*FR3 and FR3A Rail Fittings
may be ordered in HEMLOCK

7009
Returned End

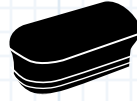

7009

7010
Starting Easing



7010



7011

7011
Level Quarterturn

7012
Up Easing



7012



7013

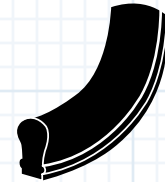

7014

7013
Over Easing

7014
90 Up Easing

7019
Opening Cap

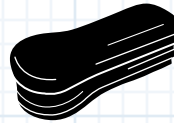

7019

7020
Tandem Cap

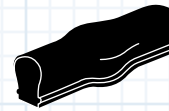

7020



7021

7021
Level Quarterturn w / Cap

7030
Left Hand Volute

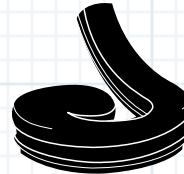

7030

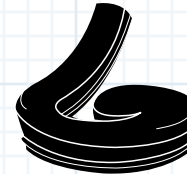

7035

7035
Right Hand Volute

7040
Left Hand Turnout

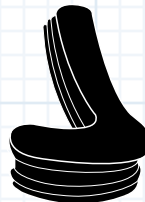

7040

7045
Right Hand Turnout

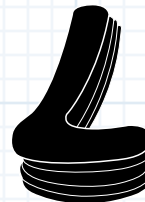

7045

7041
Left Hand Short Turnout



7041

7046
Right Hand Short Turnout



7046

OAK RAIL FITTINGS

7050
 Left Hand, 2-Riser
 Gooseneck w / Up Ease

7055
 Right Hand, 2 Riser
 Gooseneck w / Up Ease

7060
 Left Hand, 2 Riser
 Gooseneck w / Cap & Up Ease

7065
 Right Hand, 2 Riser
 Gooseneck w / Cap & Up Ease

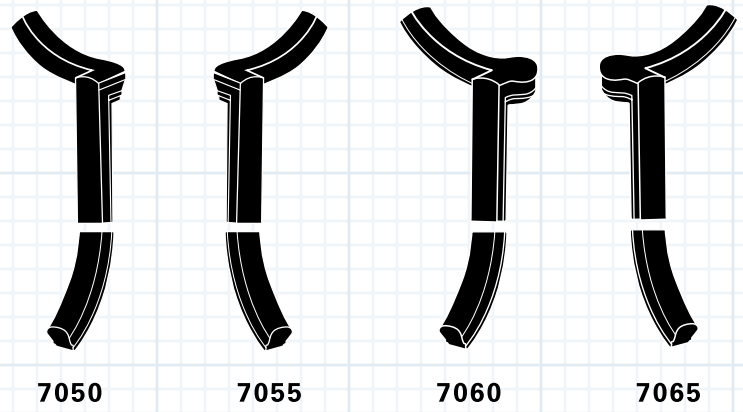

7070
 Left Hand, 1 Riser
 Gooseneck

7075
 Right Hand, 1 Riser
 Gooseneck

7080
 Left Hand, 1 Riser
 Gooseneck w / Cap

7085
 Right Hand, 1 Riser
 Gooseneck w / Cap

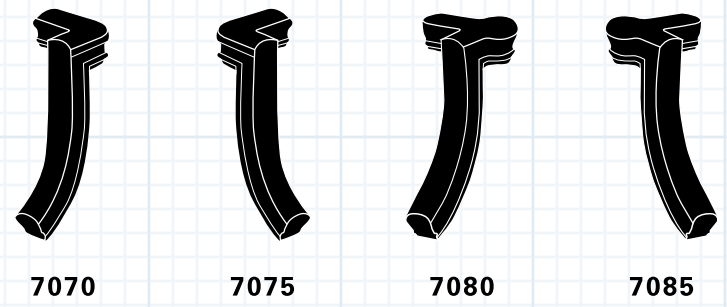

7090
 Left Hand, 1 Riser
 U-Shaped Gooseneck

7095
 Right Hand, 1 Riser
 U-Shaped Gooseneck

7090 WC
 Left Hand, 1 Riser
 U-Shaped Gooseneck w / Cap

7095 WC
 Right Hand, 1 Riser
 U-Shaped Gooseneck w / Cap

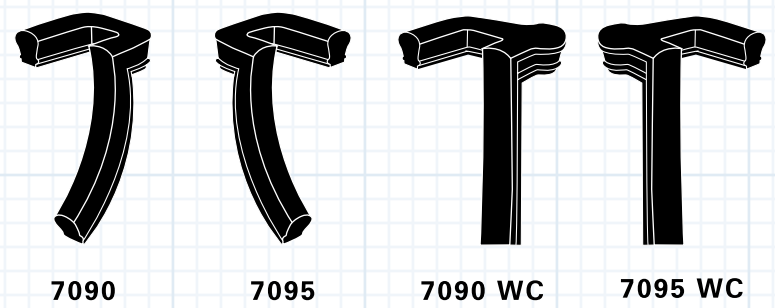

OAK RAIL FITTINGS

*FR3 and FR3A Rail Fittings
may be ordered in HEMLOCK

7088
Straight
1-Riser Gooseneck
w / Tandem Cap



7088

7096
Straight
1-Riser Gooseneck
w / Opening Cap



7096

7098
Straight
1-Riser Gooseneck



7098

ROSETTES

MR02
Oak
Rosette
W- 4 1/2" H- 4 1/2"

MR02

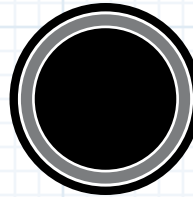

MR03
Oak
Rosette
W- 4" H- 5 1/2"

MR03

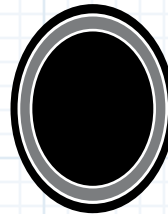

MR04
Alder
Non- Cupped Rosettes
W- 4 1/2" H- 4 1/2"

MR04

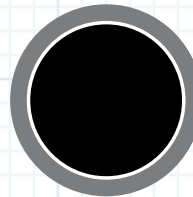

SPECIAL ORDER

OAK STARTING STEPS & ACCESORIES

Special Order in Oak Only

7028
Stair Bracket

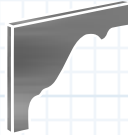

FB4

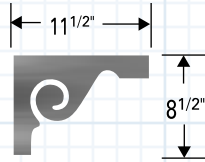

FB5

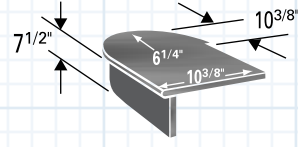

8010-2

7029
Stair Bracket

8010-2
False Starting Step

8010-48

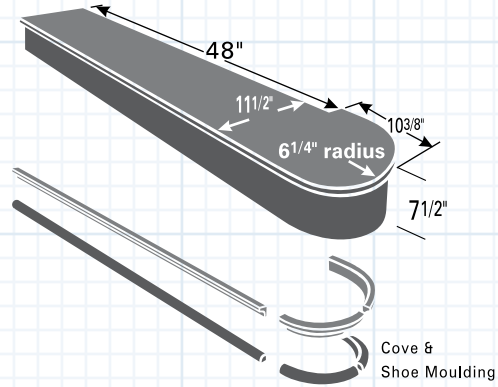

8010-48
48" Starting Step
Single End For Volute
& Turnout

Starting Steps Include
Cove & Shoe Moulding Sets

8015-48
48" Starting Step
Double End For Volute
& Turnout

8015-48

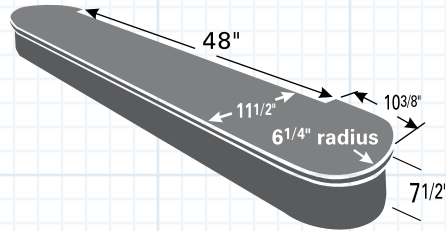

Starting Steps Include
Cove & Shoe Moulding Sets
(Shown above in 8010-48)

8071
False Tread

8071

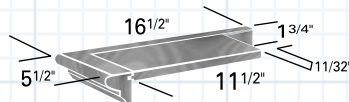

8072
Wall Cap

8076

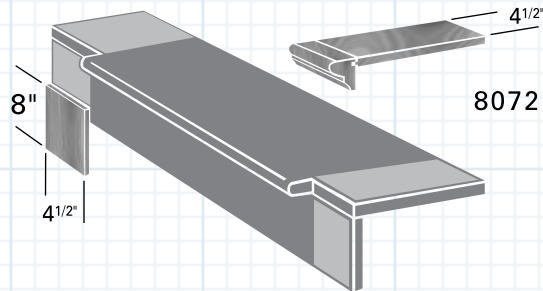

8076
False Riser

8095
Lineal Cove Moulding
5/8" X 3/4"

8095

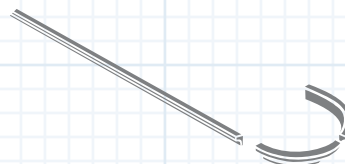

STAIR HARDWARE

HD6-1
Die Cast Brass Plated

HD6-2
Die Cast Bronze Plated

HD6-3
Die Cast Aluminum Plated

HD6-4
Die Cast White Plated

HD6-5
Solid Brass

HD6-6
Solid Brass / Chrome Plated

HD6-7
Die Cast Antique Brass

HD6-8
Oil Rubbed / Bronze (Ext or Int)

HD6-9
Satin Nickel

3 3/16" Over All Projection
2 5/8" Projection From Wall To Rail
2 9/16" Long Base x 1 3/8" W



HD7-1
Polished Solid Brass
Curved Plain Flange
Holds 1 1/2"-2" Round Rail

3 5/16" Over All Projection
2" Projection From Wall To Rail
2 1/4" Round Base



HD7-2
Polished Solid Brass
Curved Screw Flange
Holds 1 1/2"- 2" Round Rail

3 5/16" Over All Projection
2" Projection From Wall To Rail
2 1/4" Round Base



HD7-3
Polished Solid Brass
Flat Flange

3" Over All Projection
2" Projection From Wall To Rail
2 1/4" Round Base



STAIR HARDWARE

HD8-7
Smooth Solid Brass / Bronze Finish

3 5/8" Over All Projection
2 9/16" Projection From Wall To Rail
3" Round Base

HD8-8
Smooth Aluminum /
Satin Aluminum Finish

HD8-9
Smooth Solid Brass / Chrome Plated

HD8-7 / HD8-8 / HD8-9



HD1
1" Oak / Birch Plugs



HD1

HD2
Railbolt Set
5/16" x 31/2"



HD2

HD2A
Newel Fastening Bolt
1/2" x 10 1/2"
1 1/2" Oak Plug



HD2A

HD3
Splice Screw
5/16" x 3"



HD3

HD9
Oak & Fir
Newel Anchoring Hardware
3 1/4" Hemlock
3" & 3 1/2" Oak



HD9

CEDAR NEWEL POSTS

CN1
Colonial Ball Top
3 1/4" x 48"

CN2
Colonial Ball Top
3 1/4" x 60"

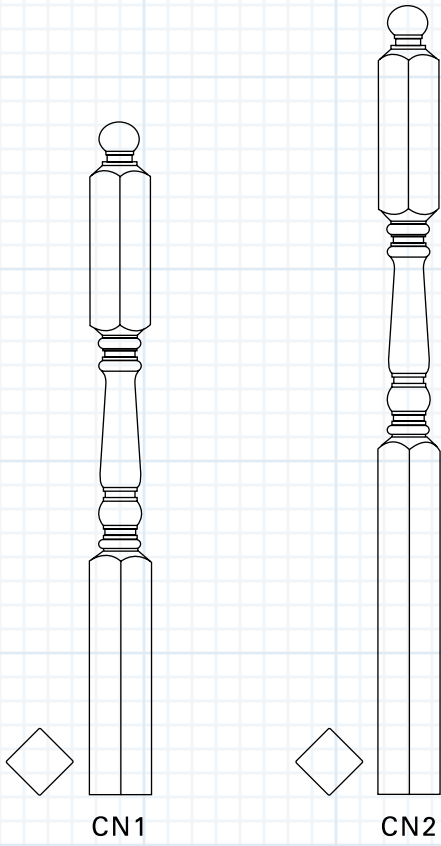

CN11
Contemporary
3 1/4" x 48"

CN12
Contemporary
3 1/4" x 54"

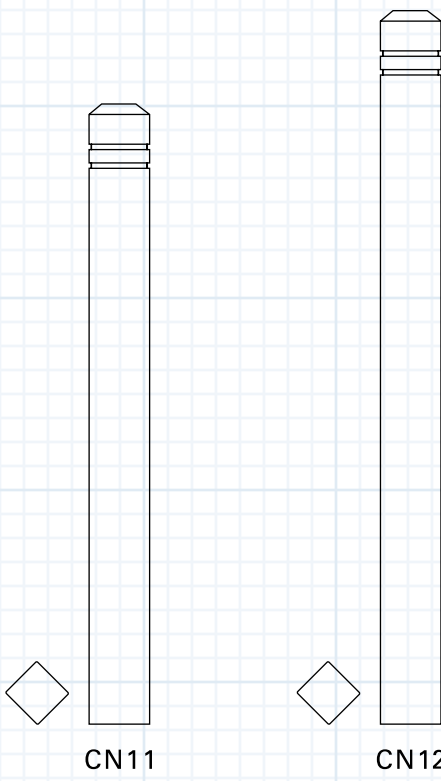

CEDAR BALUSTERS

CB1
Colonial
1 7/16" x 36"

CB4
Corner Fluted
Chamfered Top
2 1/4" x 36"

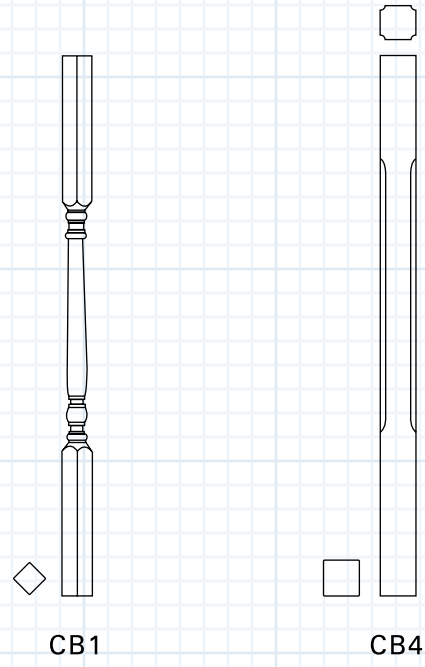

CB5
Colonial
2 1/4" x 36"

CB6
Colonial
3 1/4" x 36"

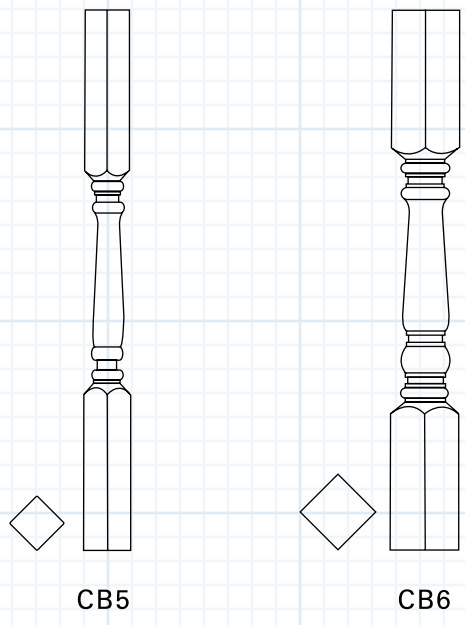

BALL FINIALS

PP1B
Ball Top
5 1/2" x 60"

PP1A
Acorn Top
5 1/2" x 60"



PP1B
Ball Top



PP1A
Acorn Top

SPECIAL ORDER

NEW ORLEANS / COLONIAL WOOD PORCH POSTS

New Orleans

Base	41 5/8"
Turning	40 3/8"
Top	14"
W-N148-4"	H-96"
W-N158-5"	H-96"
W-N168-6"	H-96"

Base	53 5/8"
Turning	40 3/8"
Top	14"
W-N149-4"	H-108"
W-N159-5"	H-108"
W-N169-6"	H-108"

Colonial

Base	32"
Turning	40"
Top	24"
W-3048-4"	H-96"
W-3058-5"	H-96"
W-3068-6"	H-96"

Base	42"
Turning	40"
Top	14"
W-3148-4"	H-96"
W-3158-5"	H-96"
W-3168-6"	H-96"

Base	44"
Turning	40"
Top	24"
W-3049-4"	H-108"
W-3059-5"	H-108"
W-3069-6"	H-108"

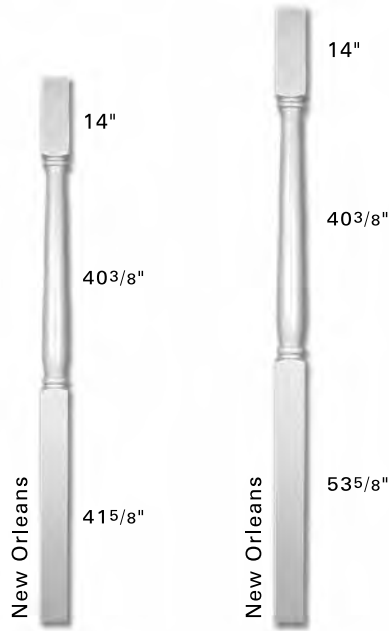

W-N148-4"
W-N158-5"
W-N168-6"



W-N149-4"
W-N159-5"
W-N169-6"



W-3048-4"
W-3058-5"
W-3068-6"



W-3148-4"
W-3158-5"
W-3168-6"



W-3049-4"
W-3059-5"
W-3069-6"

REDWOOD NON SLIP OVER CAPS

Nantucket

PC3 4" x 4"
 PC5 6" x 6"

Nantucket



Vineyard

PC4 4" x 4"
 PC6 6" x 6"

Vineyard



South Hampton

PC7 4" x 4"

South Hampton



REDWOOD SLIP OVER CAPS

Federal

PC8 4" x 4"
 PC9 6" x 6"

Federal



Island

PC10 4" x 4"
 PC11 6" x 6"

Island



Harbor

PC12 4" x 4"
 PC13 6" x 6"

Harbor



COPPER POST CAPS

PC14
High Top Copper
4" x 4"



PC14

PC15
Large Copper
Pyramid
6" x 6"



PC15
6" x 6"

PC16
Small Copper
Pyramid
4" x 4"



PC16
4" x 4"

PC17
Ball Top
4" x 4"



PC17

BALL FINIALS

CEDAR POST CAPS

PC24
Provincial
3"

PC25
Westcoast
4"

PC26
Georgian
4"

PC27
Cape
5"

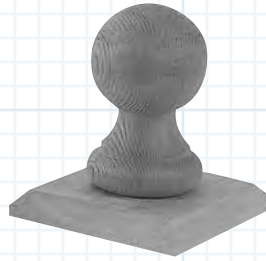

PC24

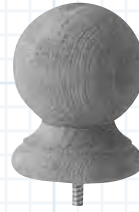

PC25



PC26

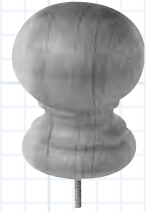

PC27

CEDAR ROUND BALL FINIALS

BF40
4"

BF60
6"



BF40



BF60



AF4



AF6

CEDAR ACORN FINIALS

AF4
4"

AF6
6"

TURNCRAFT

Poly-Classic Tapered Round Columns

Poly-Classic Non-Tapered Round Columns

Poly-Classic Non-Tapered Square Columns

Poly-Classic FRP Columns are available in fluted and unfluted round, tapered shafts in sizes ranging from 6" x 6' to 24" x 20'; in round, non-tapered shafts from 8" x 8' to 14" x 14'; and in square, non-tapered shafts from 8" x 8' to 12" x 16'.

Columns are available in popular non-tapered shafts and feature concise edges and meticulous detail on every visible surface.

All Poly-Classic Columns are non-porous, waterproof, and impervious to termite and carpenter ant attack, as well as staining and decaying fungi. High humidity environments that are so hard on wood have no effect on these columns; they are rot-proof because they absorb virtually no moisture.

Limited Lifetime Warranty

Turncraft is so confident in its manufacturing processes for Poly-Classic and Classic-Wound Columns, that it offers a Limited Lifetime Warranty to the original owner. Turncraft warrants that Poly-Classic and Classic-Wound Columns will be free of defects in material and workmanship for as long as the original purchaser owns the structure to which they are attached.



TURNCRAFT

COLONIAL WOOD COLUMNS

Turncraft Colonial round columns may be ordered with or without fluting in standard shaft diameters and lengths from 6" x 6' to 24" x 24', and in custom shaft diameters up to 30" and lengths to 30'. They are available in tapered and non-tapered versions and in a wide variety of plan styles. Square Columns are also available in smooth or fluted designs.

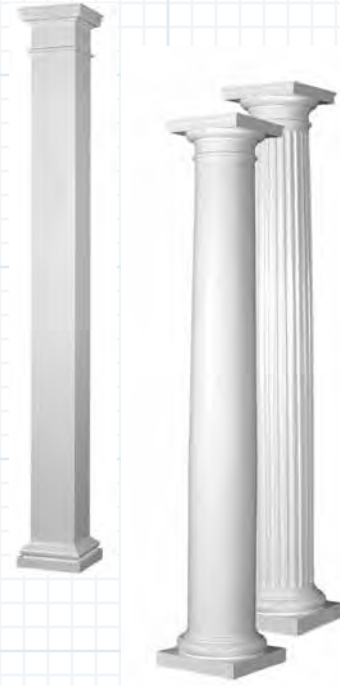

TURNCRAFT

ARCHITECTURAL COLUMNS

So many architects and builders select Turncraft Architectural Columns because they feature thoughtful product design, fine workmanship, superior assembly, precision turning and fluting, and artful finishing.

Round columns may be ordered with true architectural entasis in sizes consistent with the classic proportions of the Greek Doric, Tuscan, Roman Doric, Ionic, and Corinthian Orders, or in custom shaft diameters up to 36" and lengths of 30'. They can be smooth surfaced or given dramatic deep fluting (with increased stave thickness) as desired. Greek Doric Columns feature classic edge-to-edge fluting. Square columns and pilasters may be ordered to match (available in tapered or non-tapered, and in various plan styles).

Stain-grade interior columns are fashioned primarily from solid-stave Red Oak, Poplar, Hard Maple, Pine, Cherry, Redwood, Mahogany and Black Walnut lumber, and feature matching wood Caps and Bases.

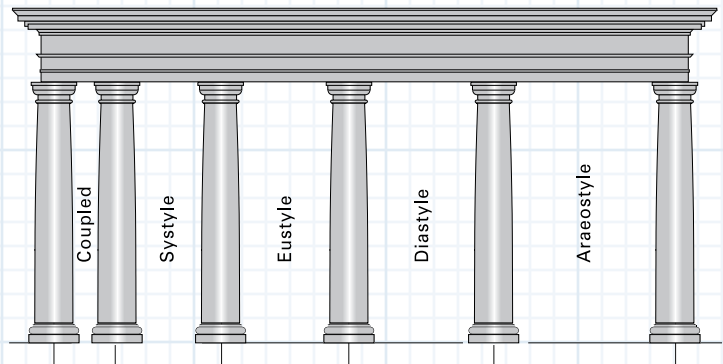

TURNCRAFT

CAPITALS & BASES

Exterior and paint-grade interior columns feature polyurethane or fiberglass Caps & Bases to provide crisp, true architectural detail and increased durability. (Special-order wood Caps & Bases are available). Optional aluminum plinths provide an extra measure of protection.

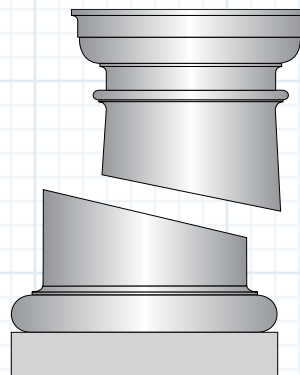

TURNCRAFT

CAPITALS & BASES

The volute scrolls of the Ionic, Erechtheum, Scamozzi, and Empire imitate the helix cross-section of the Nautilus shell. The Acanthus leaves on the temple of Winds and Corinthian Capitals echo the flowering crown of a tree. These capitals are crafted from a number of materials including wood, plaster, and fibers, and are shaped into the appropriate proportions for the various styles of architecture and sizes of column shafts.

- 1 Empire
- 2 Greek Angular Ionic
- 3 Roman Ionic
- 4 Temple Of Winds
- 5 Roman Doric Ornamental
- 6 Roman Corinthian
- 7 Scamozzi
- 8 Greek Erechtheum

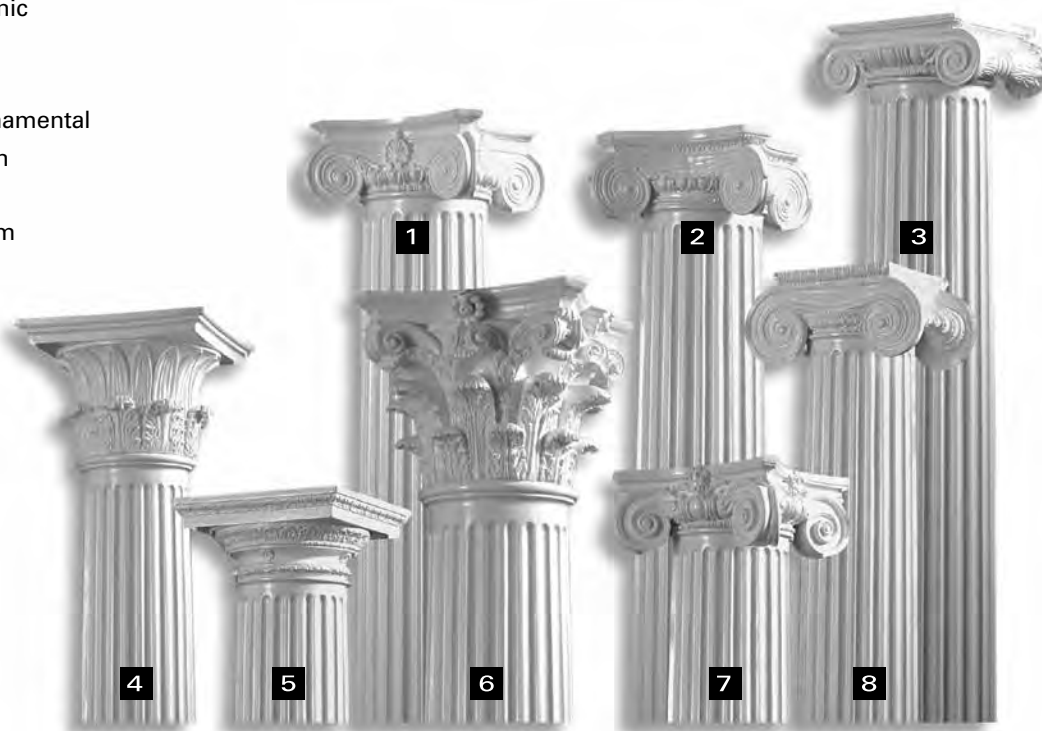

TURNCRAFT

COLUMN PLAN TYPES

Turncraft Columns are available in the following plan types.

Please specify when you order.

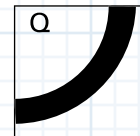
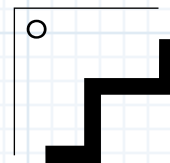
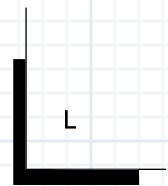
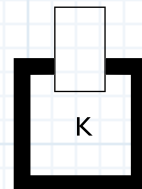
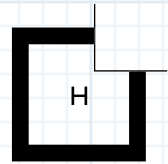
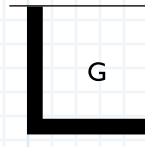
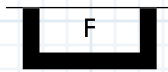
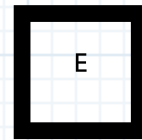
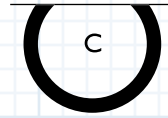
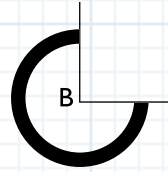
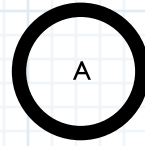

Beronio
L U M B E R

2525 MARIN STREET • SAN FRANCISCO, CA 94124
P 415-824-4300 • F 415-824-3706
www.Beronio.com